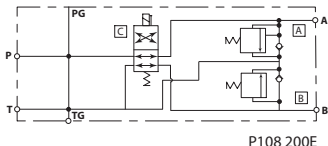
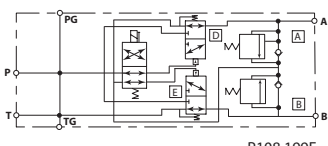
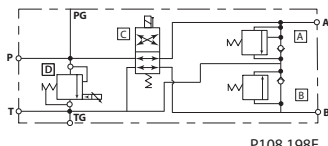
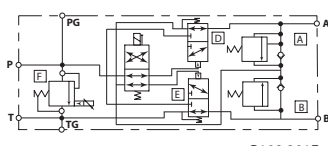

Fan Drive HICs	Model No.	Cavity	Description	Flow*	Pressure	Page
 <p>P108 200E</p>	RFD-40-000	none	Fan Drive HIC with Reversing Control	Up to 40 l/min [10.5 US gal/min] See performance chart	210 bar [3000 psi]	14.6
	RFD-80-000	none		Up to 80 l/min [21.1 US gal/min] See performance chart	210 bar [3000 psi]	14.8

Fan Drive HICs	Model No.	Cavity	Description	Flow*	Pressure	Page
 <p>P108 199E</p>	RFD-120-000	none	Fan Drive HIC with Reversing Control	Up to 120 l/min [31.7 US gal/min] See performance chart	210 bar [3000 psi]	14.10

Fan Drive HICs	Model No.	Cavity	Description	Flow*	Pressure	Page
 <p>P108 198E</p>	RFD-40-PRV	none	Fan Drive HIC with Proportional and Reversing Control	Up to 40 l/min [10.5 US gal/min] See performance chart	210 bar [3000 psi]	14.12
	RFD-80-PRV	none		Up to 80 l/min [21.1 US gal/min] See performance chart	210 bar [3000 psi]	14.14

Fan Drive HICs	Model No.	Cavity	Description	Flow*	Pressure	Page
 <p>P108 201E</p>	RFD-120-PRV	none	Fan Drive HIC with Proportional and Reversing Control	Up to 120 l/min [31.7 US gal/min] See performance chart	210 bar [3000 psi]	14.16

* Flow ratings are based on a pressure drop of 7 bar [100 psi] unless otherwise noted. They are for comparison purposes only.

OVERVIEW

Off-highway mobile machinery OEMs and distributors can choose from six pre-engineered Hydraulic Integrated Circuits (HICs) designed to provide speed control and reversing for hydraulic modulating fan drive motors in open circuit hydraulic fan drive systems. The program includes:

- 40, 80, and 120 LPM Frame Sizes
- Variable piston pump or fixed pump circuits
- Over-Pressure Protection / Anti-Cavitation is standard
- Viton O-rings are standard

	40 LPM	80 LPM	120 LPM
	RFD-40-000	RFD-80-000	RFD-120-000
Variable pump fan drive circuits: - Provide reversing control and over-pressure protection/anti-cavitation			
Fixed pump fan drive circuits: - Provide modulating and reversing control with over-pressure protection/anti-cavitation			
	RFD-40-PRV	RFD-80-PRV	RFD-120-PRV

Functions

Proportional relief valve:

- Regulates fan speed by controlling pressure drop across fan motor
- Normally closed to ensure full fan speed in the absence of electrical signal
- PLUS+1® compliant

Solenoid reversing valve:

- Reverses flow to the fan motor to reverse fan direction
- Open transition spool to reduce the likelihood of pressure spikes during reversals
- Sized to minimize parasitic losses due to pressure drop

Dual shock valve with anti-cavitation checks:

- Trims the maximum motor torque by absorbing pressure spikes (shock effects) at the work ports
- Anti-cavitation feature allows additional flow to the motor through the tank port when motor overruns the pump
- PVLP shock valves (from PVG) allow for a compact design

Custom designs available upon request.

Circuits - Variable Pump or Fixed Pump

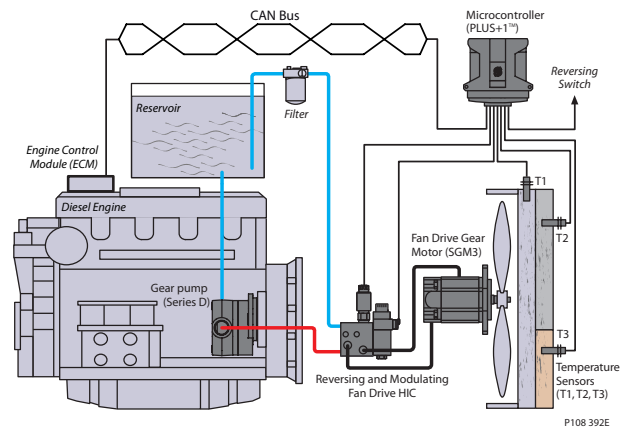
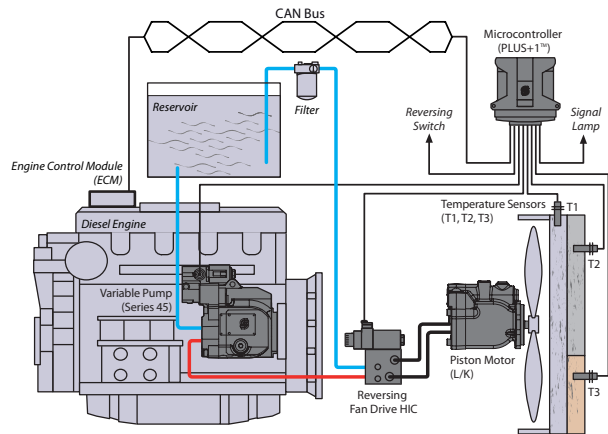

RFD-xx-000

- Variable Pump fan drive circuits
- HIC provides reversing control and over-pressure protection/anti-cavitation
- Variable pump provides modulation (speed control)

RFD-xx-PRV

- Fixed Pump fan drive circuits
- HIC provides modulating and reversing control with over-pressure protection/anti-cavitation

Features

Integrated and compact design with customer flexibility in mind:

- Designed and tested specifically for fan drive systems
- Configurable for quick availability

Proportional control allows the engine temperature to be controlled within narrow limits:

- Helps meet the requirements of new emissions legislation
- The engine can be run more efficiently - improving fuel economy and reducing emissions

Increased design flexibility and scalability:

- Multiple frame sizes that allow you to match to your flow and pressure drop requirements for multiple machines and their respective fan requirements
- HIC valve can be placed in the most suitable location on the machine
- Reduce parasitic losses by limiting flow to and from the fan drive motor
- The gear motor is shorter compared to a fan motor with integrated valve
- Two sets of mounting holes for mounting flexibility (SAE and Metric compatible)

Features (continued)

Increased productivity:

- Fan is reversible to purge (de-clog) coolers and radiators
- Prevents overheating with purged cooler
- More power available for useful work when radiator is not clogged

Automatic cleaning sequence programmed using PLUS+1™:

- Manual or automatic activation
- Reference Sauer-Danfoss 'Fan Drive Application Block' information
- Service screen below illustrates an example reversing fan drive software setup

Service screen below illustrates an example reversing fan drive software setup

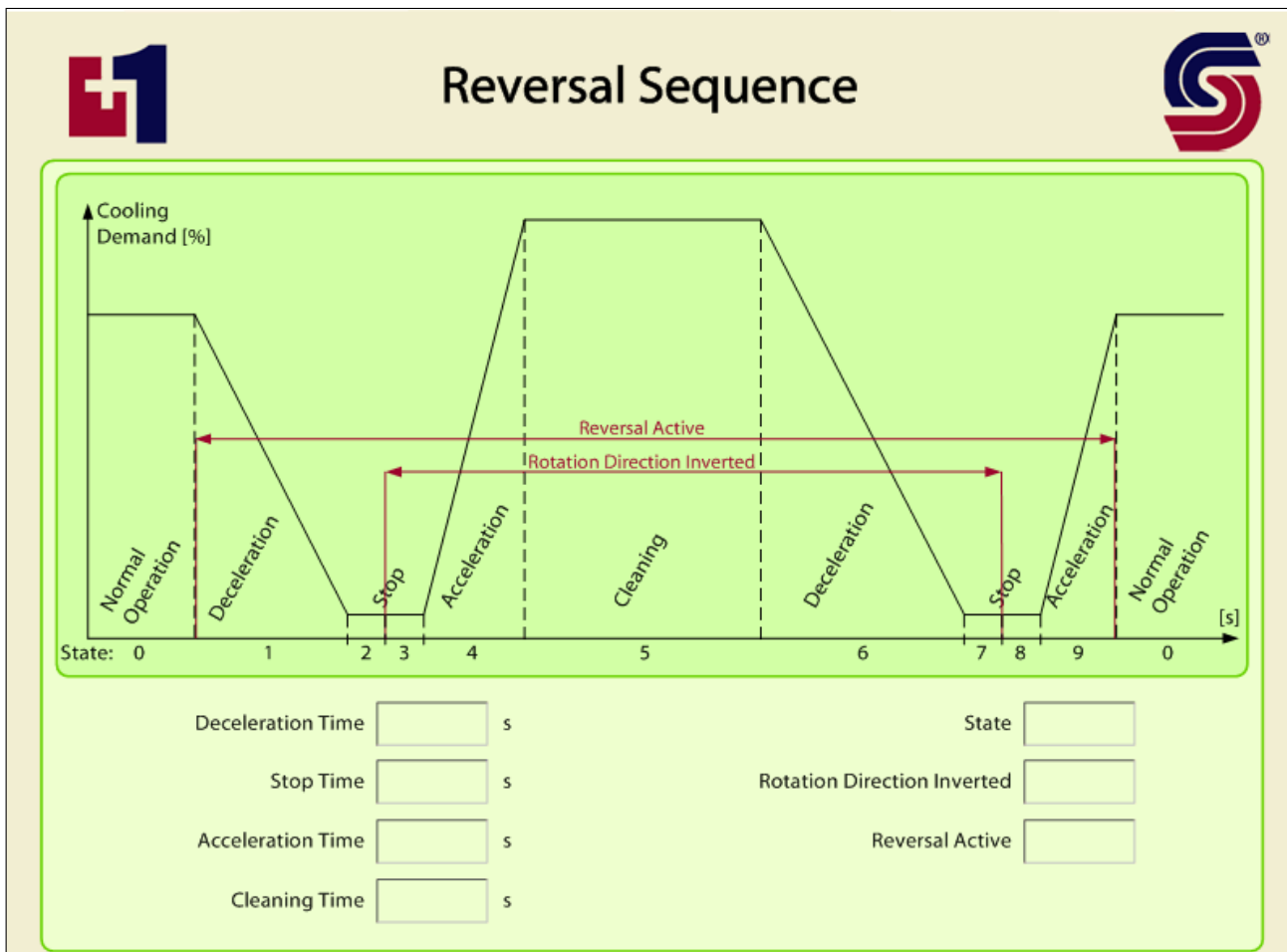

Cartridge Valves Technical Information
 Fan Drive HICs
 Fan Drive HIC with Reversing Control
 RFD-40-000

OPERATION

This valve reverses flow to the fan motor to reverse fan direction. It includes an open transition spool to reduce pressure spikes during reversals.

It trims the maximum motor torque by absorbing pressure spikes at the work ports. An anti-cavitation feature allows additional flow to the motor when the motor over-runs the pump.

SPECIFICATIONS

Rated pressure	210 bar [3000 psi]
Flow	Up to 40 l/min [10.5 US gal/min] See performance chart
Weight	3.23 kg [7.11 lb]
Valves	DCV03, PVLP
Gauge Port Size	#4 SAE [1/4 BSP]

THEORETICAL PERFORMANCE

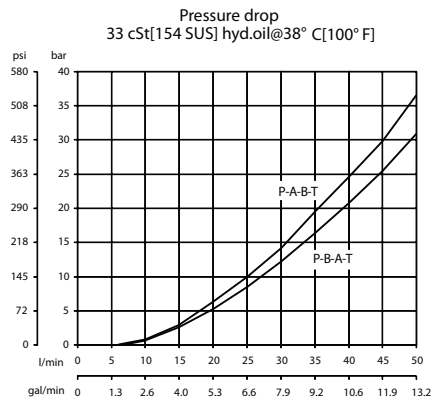

P108 294E

DIMENSION DRAWING

Dimensions mm [in]

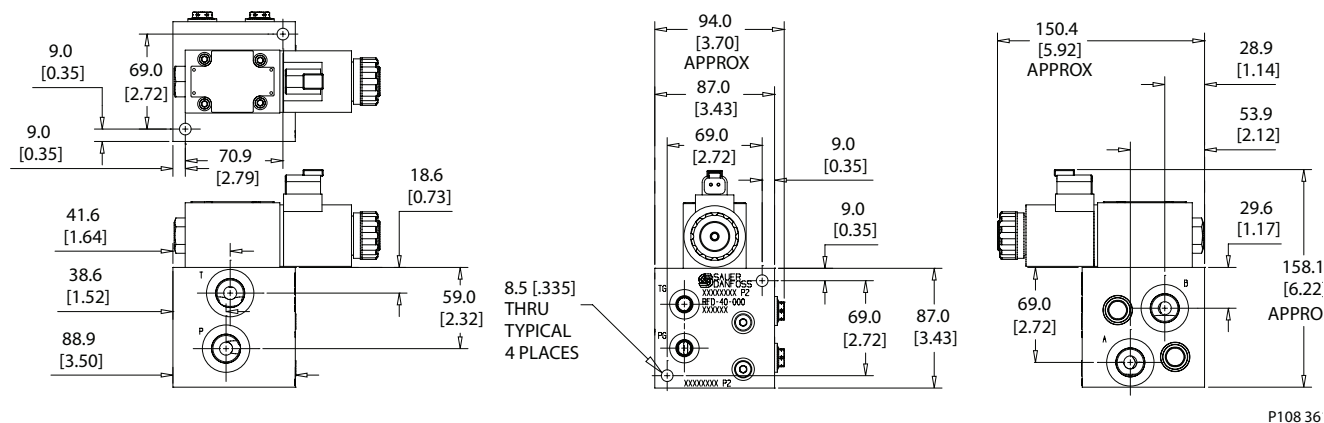

P108 36

SCHEMATIC

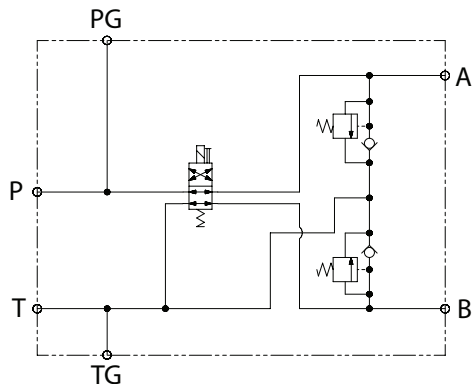

P108 293E

ORDERING INFORMATION

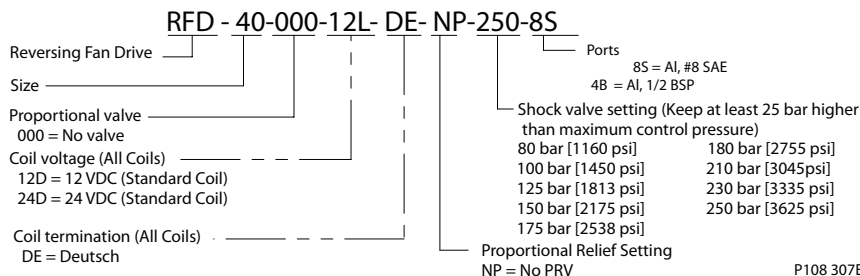

P108 307E

Cartridge Valves Technical Information
 Fan Drive HICs
 Fan Drive HIC with Reversing Control
 RFD-80-000

OPERATION

This valve reverses flow to the fan motor to reverse fan direction. It includes an open transition spool to reduce pressure spikes during reversals.

It trims the maximum motor torque by absorbing pressure spikes at the work ports. An anti-cavitation feature allows additional flow to the motor when the motor over-runs the pump.

SPECIFICATIONS

Rated pressure	210 bar [3000 psi]
Flow	Up to 80 l/min [21.5 US gal/min] See performance chart
Weight	6.74 kg [14.86 lb]
Valves	DCV05, PVLP
Gauge Port Size	#4 SAE [1/4 BSP]

THEORETICAL PERFORMANCE

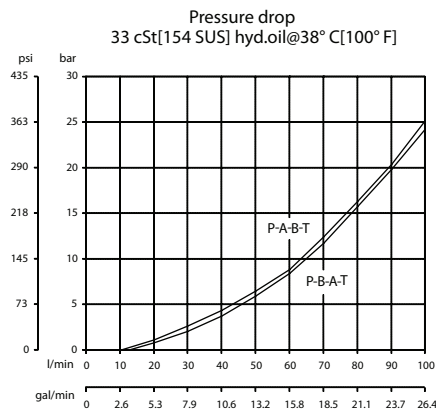

P108 306E

DIMENSION DRAWING

Dimensions mm [in]

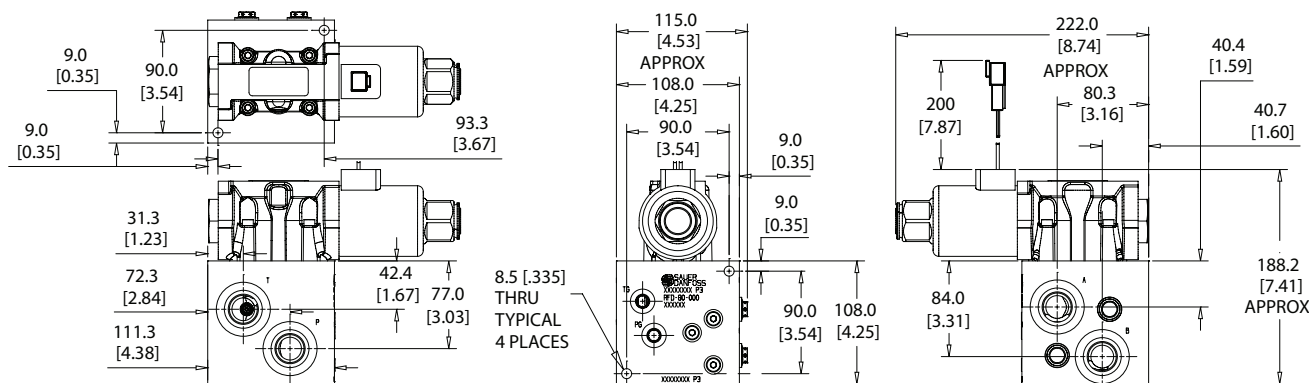

P108 296E

SCHEMATIC

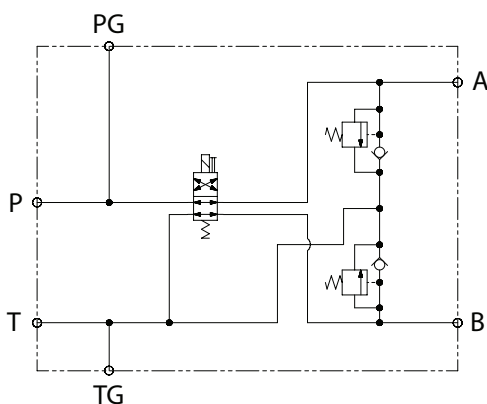

P108 305E

ORDERING INFORMATION

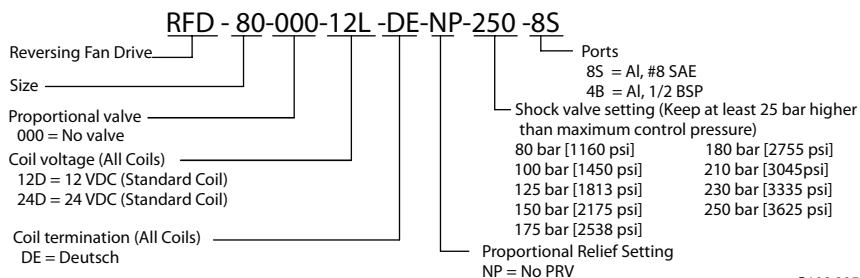

P108 295E

Cartridge Valves Technical Information
 Fan Drive HICs
 Fan Drive HIC with Reversing Control
 RFD-120-000

OPERATION

This valve reverses flow to the fan motor to reverse fan direction. It includes an open transition spool to reduce pressure spikes during reversals.

It trims the maximum motor torque by absorbing pressure spikes at the work ports. An anti-cavitation feature allows additional flow to the motor when the motor over-runs the pump.

SPECIFICATIONS

Rated pressure	210 bar [3000 psi]
Flow	Up to 120 l/min [31.7 US gal/min] See performance chart
Weight	4.26 kg [9.40 lb]
Valves	CP722-5, SV08-24-01, PVLP
Gauge Port Size	#4 SAE [1/4 BSP]

THEORETICAL PERFORMANCE

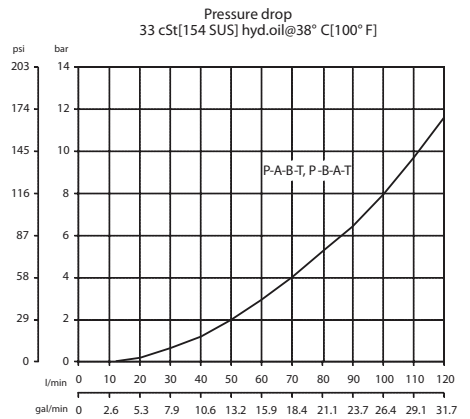

P108 309E

Cartridge Valves Technical Information
 Fan Drive HICs
 Fan Drive HIC with Reversing Control
 RFD-120-000

DIMENSION DRAWING

Dimensions mm [in]

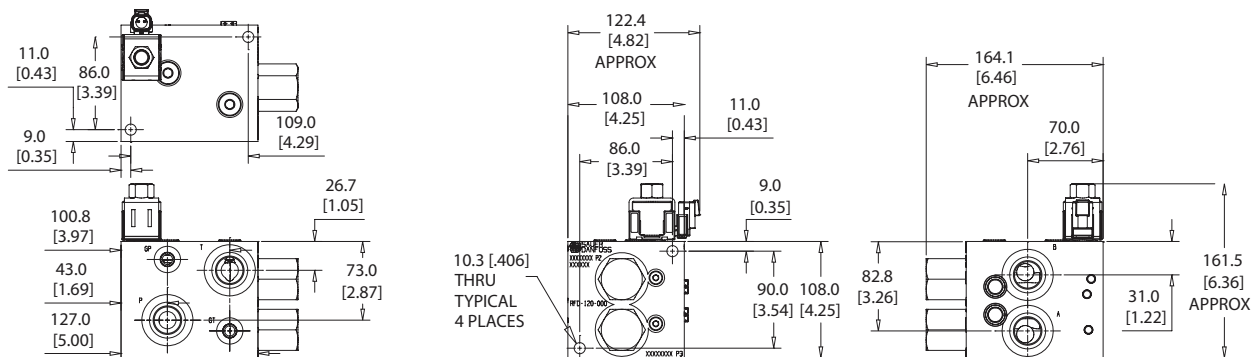

P108 310E

SCHEMATIC

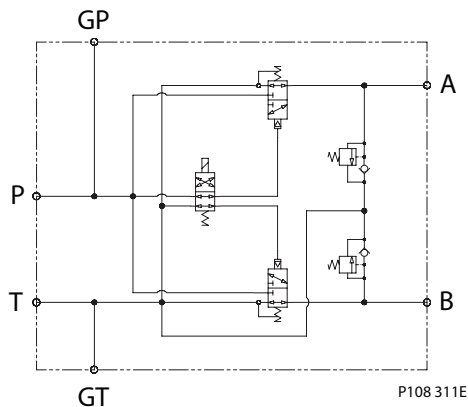

P108 311E

ORDERING INFORMATION

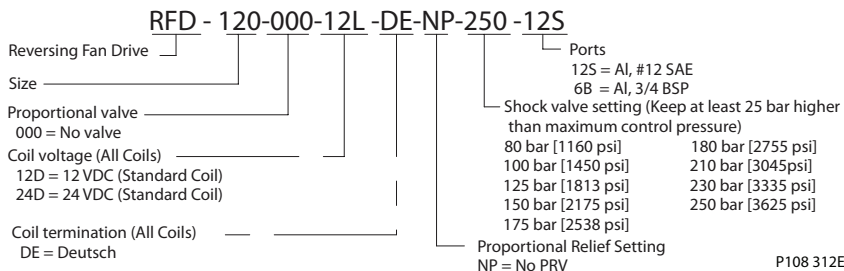

P108 312E

Cartridge Valves Technical Information

Fan Drive HICs

Fan Drive HIC with Proportional and Reversing Control

RFD-40-PRV

OPERATION

This valve regulates fan speed by controlling pressure drop across the fan motor. It operates in a normally closed configuration in the absence of an electrical signal.

The valve reverses flow to the fan motor to reverse fan direction. It includes an open transition spool to reduce pressure spikes during reversals.

It trims the maximum motor torque by absorbing pressure spikes at the work ports. An anti-cavitation feature allows additional flow to the motor when the motor over-runs the pump.

SPECIFICATIONS

Rated pressure	210 bar [3000 psi]
Flow	Up to 40 l/min [10.5 US gal/min] See performance chart
Weight	4.52 kg [9.96 lb]
Valves	DCV03, PRV10-IS2, PVLP
Gauge Port Size	#4 SAE [1/4 BSP]

THEORETICAL PERFORMANCE

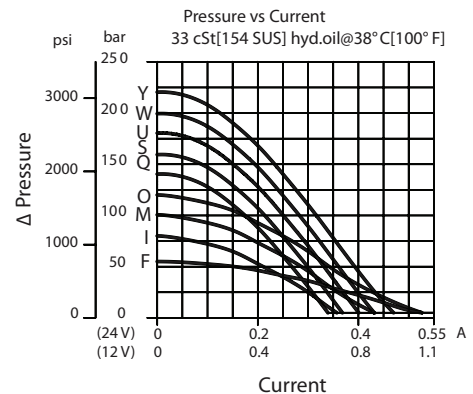
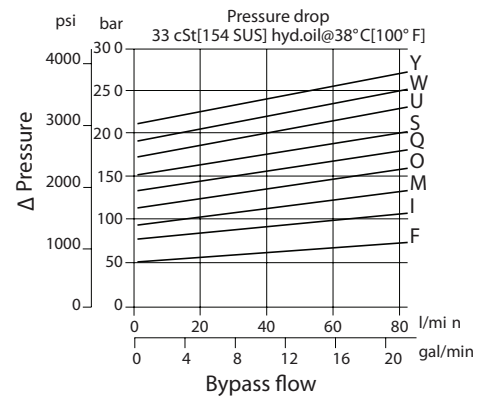
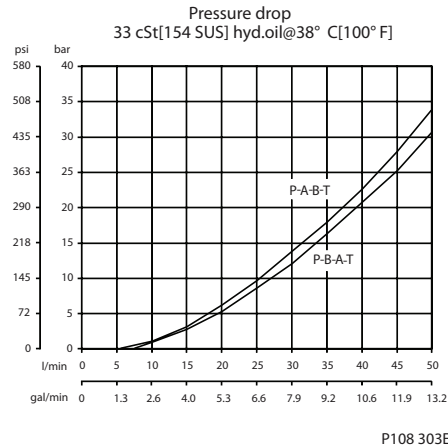

Cartridge Valves Technical Information
 Fan Drive HICs
 Fan Drive HIC with Proportional and Reversing Control
 RFD-40-PRV

DIMENSION DRAWING

Dimensions mm [in]

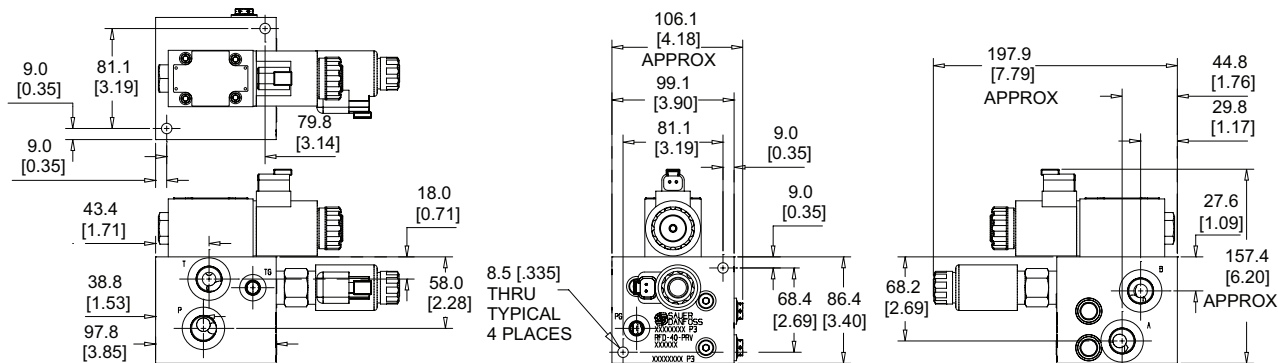

P108 304E

SCHEMATIC

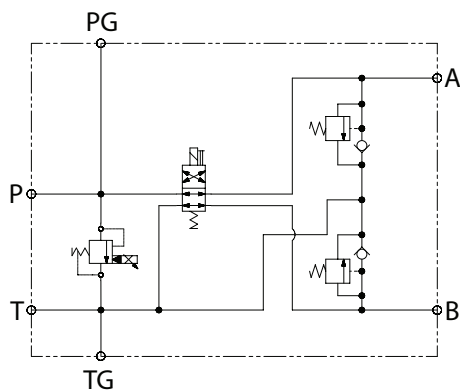

P108 301E

ORDERING INFORMATION

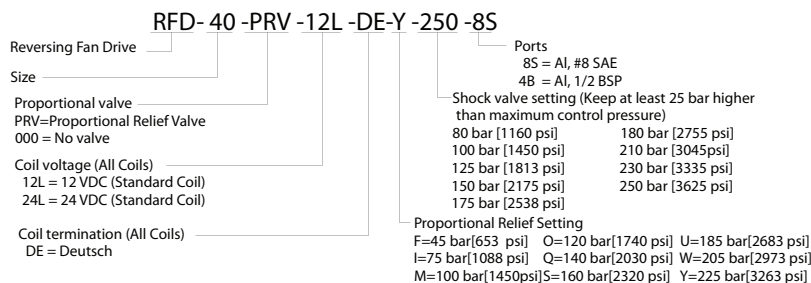

P108 303E

Cartridge Valves Technical Information

Fan Drive HICs

Fan Drive HIC with Proportional and Reversing Control

RFD-80-PRV

OPERATION

This valve regulates fan speed by controlling pressure drop across the fan motor. It operates in a normally closed configuration in the absence of an electrical signal.

The valve reverses flow to the fan motor to reverse fan direction. It includes an open transition spool to reduce pressure spikes during reversals.

It trims the maximum motor torque by absorbing pressure spikes at the work ports. An anti-cavitation feature allows additional flow to the motor when the motor over-runs the pump.

SPECIFICATIONS

Rated pressure	210 bar [3000 psi]
Flow	Up to 80 l/min [21.7 US gal/min] See performance chart
Weight	8.35 kg [18.40 lb]
Valves	DCV05, PRV12-IS2, PVLP
Gauge Port Size	#4 SAE [1/4 BSP]

THEORETICAL PERFORMANCE

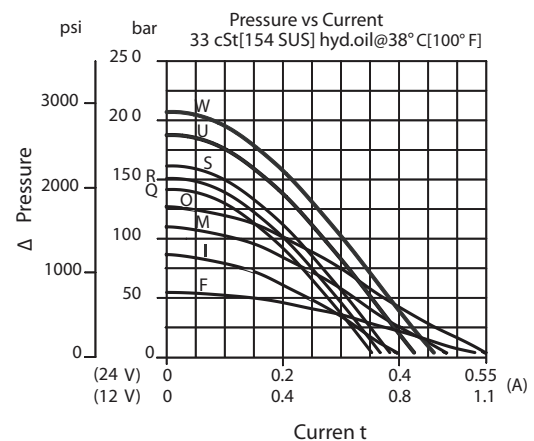
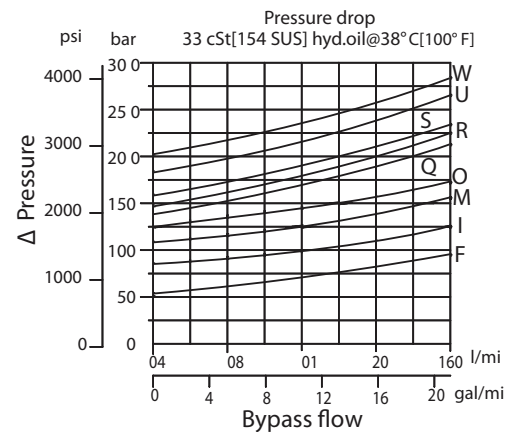
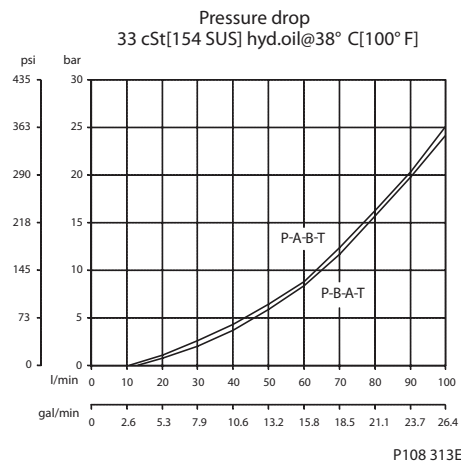

Cartridge Valves Technical Information

Fan Drive HICs

Fan Drive HIC with Proportional and Reversing Control

RFD-80-PRV

DIMENSION DRAWING

Dimensions mm [in]

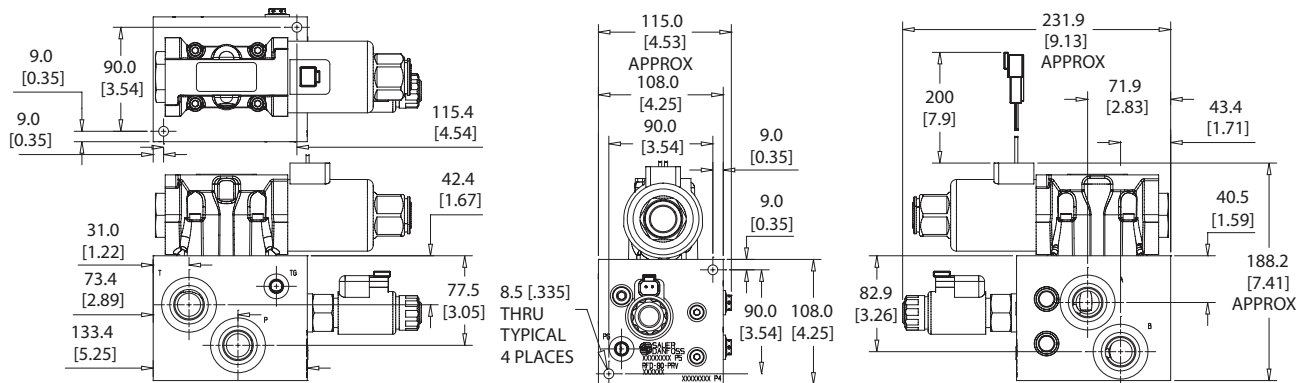

P108 314E

SCHEMATIC

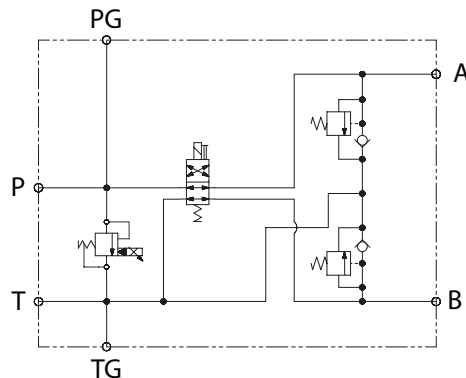

P108 315E

ORDERING INFORMATION

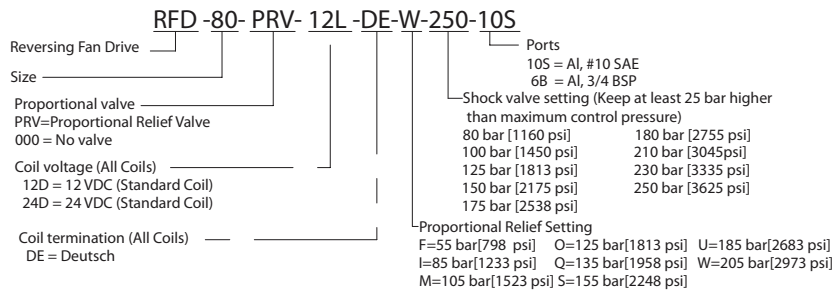

P108 116E

Cartridge Valves Technical Information
 Fan Drive HICs
 Fan Drive HIC with Proportional and Reversing Control
 RFD-120-PRV

OPERATION

This valve regulates fan speed by controlling pressure drop across the fan motor. It operates in a normally closed configuration in the absence of an electrical signal.

The valve reverses flow to the fan motor to reverse fan direction. It includes an open transition pool to reduce pressure spikes during reversals.

It trims the maximum motor torque by absorbing pressure spikes at the work ports. An anti-cavitation feature allows additional flow to the motor when the motor over-runs the pump.

SPECIFICATIONS

Rated pressure	210 bar [3000 psi]
Flow	Up to 120 l/min [31.7 US gal/min] See performance chart
Weight	15.7 kg [6.93 lb]
Valves	CP722-5, SV08-24-01, PRV12-IS2, PVLP
Gauge Port Size	#4 SAE [1/4 BSP]

THEORETICAL PERFORMANCE

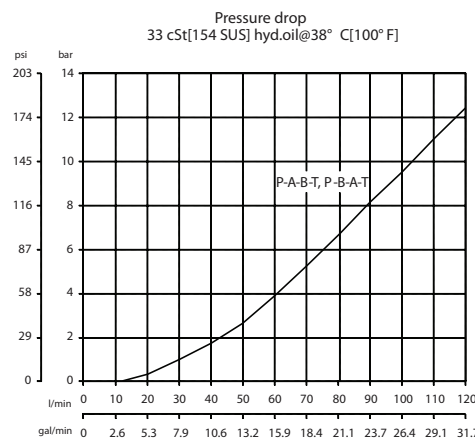

P108 317E

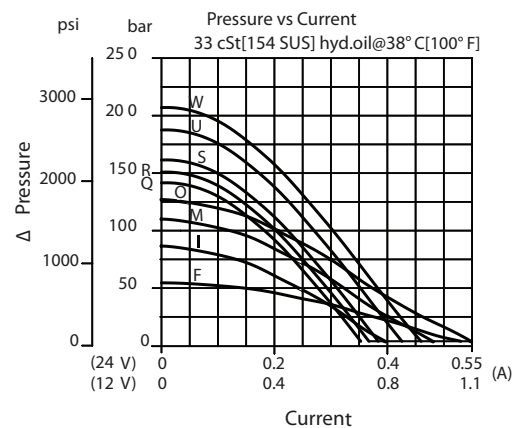
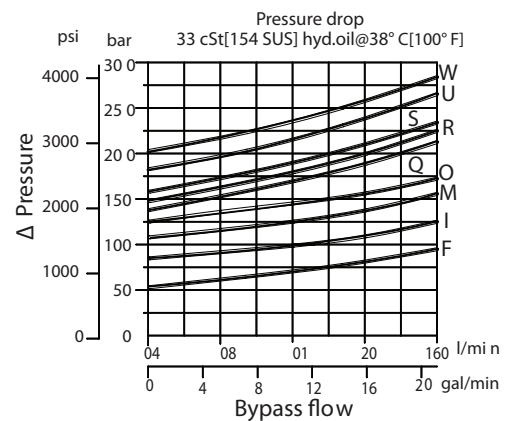

Cartridge Valves Technical Information

Fan Drive HICs

Fan Drive HIC with Proportional and Reversing Control

RFD-120-PRV

DIMENSION DRAWING

Dimensions mm [in]

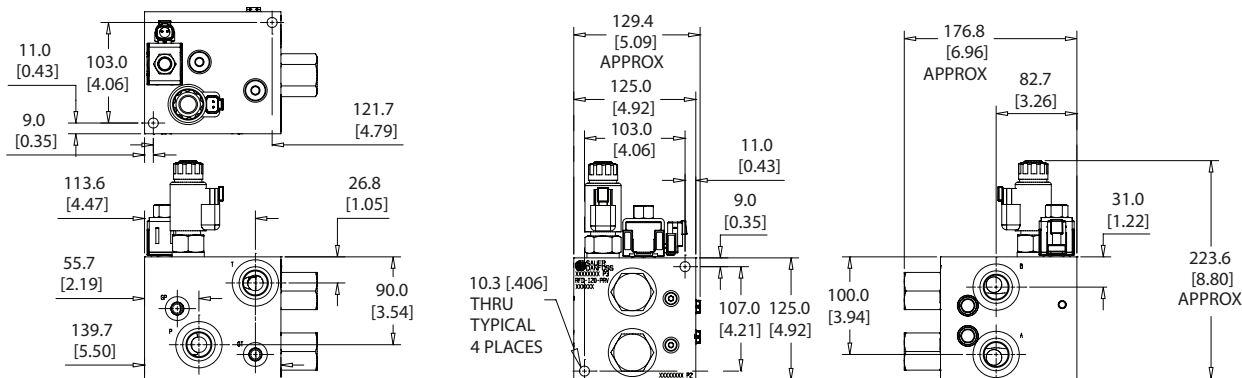

P108 318E

SCHEMATIC

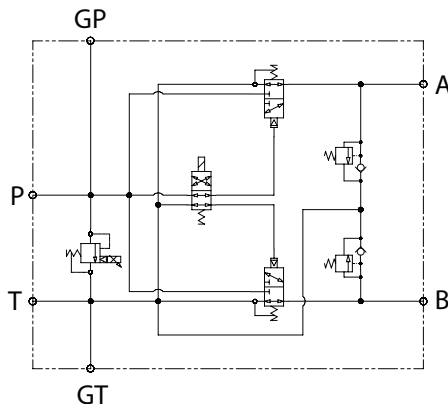

P108 319E

ORDERING INFORMATION

RFD - 120 - PRV - 12L - DE - W - 250 - 12S

Reversing Fan Drive	Ports
Size	12S = Al, #12 SAE
Proportional valve	6B = Al, 3/4 BSP
PRV=Proportional Relief Valve	Shock valve setting (Keep at least 25 bar higher than maximum control pressure)
000 = No valve	80 bar [1160 psi] 180 bar [2755 psi]
Coil voltage (All Coils)	100 bar [1450 psi] 210 bar [3045 psi]
12D = 12 VDC (Standard Coil)	125 bar [1813 psi] 230 bar [3335 psi]
24D = 24 VDC (Standard Coil)	150 bar [2175 psi] 250 bar [3625 psi]
Coil termination (All Coils)	175 bar [2538 psi]
DE = Deutsch	Proportional Relief Setting
	F=55 bar[798 psi] O=125 bar[1813 psi] U=185 bar[2683 psi]
	I=85 bar[1233 psi] Q=135 bar[1958 psi] W=205 bar[2973 psi]
	M=105 bar[1523 psi] S=155 bar[2248 psi]

P108 120E

