

Automatic filter

AF 172 G

with external pressure cleaning and integrated cyclone effect
Connection sizes: DN 40/G1 1/2, cast design

1. Short description

Filtration Group automatic backflush filters are suitable for applications where low-viscosity liquids have to be filtered.

These compact, inline filter systems are designed for automatic cleaning. The system is cleaned by rotating the element and back-flushing with external or internal pressure media.

Advantages:

- Low lifecycle costs because no filter material is consumed
- Cleaning without interrupting filtration
- Precise separation quality in accordance with the surface filter principle
- Top-quality, asymmetric filter medium made of multiple-sintered stainless steel fleece on a rugged core element
- Efficient filter cleaning assures maximum process stability
- Solid construction and high-quality materials for a long service life
- Minimal liquid loss during cleaning
- Filter cleaned one segment at a time with a high backflush pulse
- Actual filter rating and nominal separation are indicated
- Integrated preseparation thanks to tangential inflow and preseparator tube
- Material variants open up a wide range of applications
- Modular Filtration Group Vario system for optimum filter selection
- Application in Ex zone 1 and 2 optional
- Easy maintenance
- Worldwide distribution



2. Operating principle

The Filtration Group AF 172 G backflush filter belongs to the Vario series. The compact Filtration Group automatic filter system is used for fine and micro-filtration of a variety of low-viscosity liquids.

This inline pressure filter consumes no filter material, which means there is also no need for subsequent disposal. The filter is cleaned without interrupting operation. The concentrated solids are drained off simply by opening the system for a short time.

The medium to be cleaned is guided into the filter housing under pressure and flows inward through the Filtration Group segmented element. Particles settle on the surface of the filter medium. The filtered fluid exits the filter housing at the top opposite the inlet connection.

The integrated preseparator relieves the load on the segmented element, particularly from coarse and heavy particles. This is achieved by a tangential flow around the preseparator tube and the deflection edges.

The filter is cleaned when a preset differential pressure limit, a set interval or a defined filtered fluid quantity is reached.

The segmented element is turned as the cleaning and external pressure valves are opened. The segments are then guided one at a time past the pressure channel housing on the inside and the flushing channel on the outside, causing them to open and close alternately. The integrated external pressure accumulator is pretensioned during closing, so that when one segment opens, an outward surge cleans the separated particles from the filter material. As a result of this pulse cleaning principle, the particles are catapulted out, collected in the flushing channel and discharged almost entirely with external medium. One turn suffices to clean all segments.

The residue that has settled in the collection cone can be emptied via the drain valve either when the machine is at a stillstand or during filtration.

All filters of the Filtration Group Vario series are protected by various patents.

Used Filtration Group filter elements in the AF 172 G backflush filter:

Filtration Group topmesh elements (standard):

- Good cleanability due to asymmetric design
- Large effective filter surface
- Defined particle retention
- Several material combinations possible

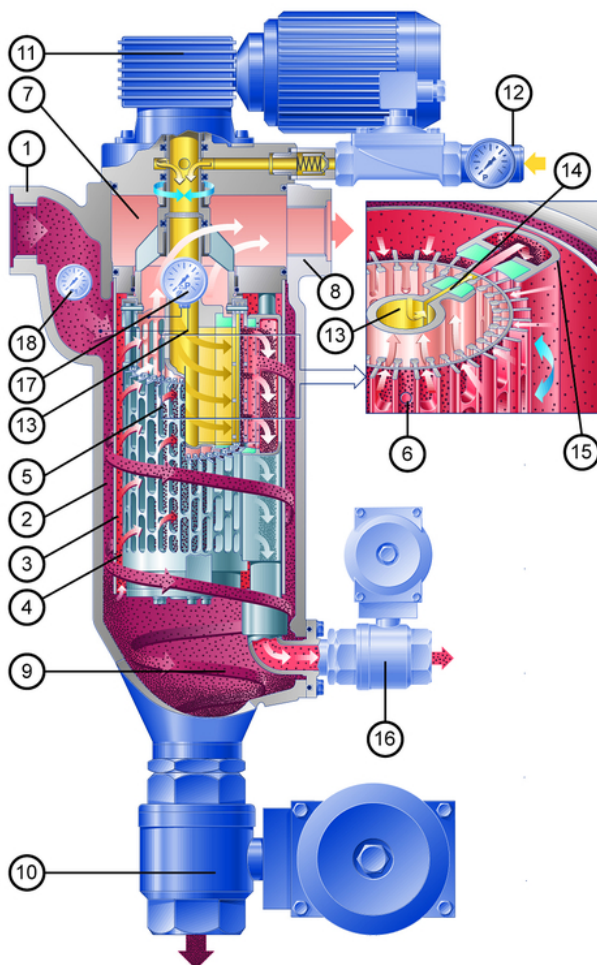
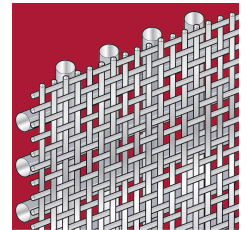

- 1 Inlet connection
- 2 Outer inlet plenum
- 3 Preseparator tube
- 4 Inner inlet plenum
- 5 Filtration Group segmented element
- 6 Filtration Group filter material
- 7 Plenum for filtered fluid
- 8 Outlet connection for filtered fluid
- 9 Residue collection cone
- 10 Drain valve
- 11 Drive motor
- 12 External pressure connection, external pressure and backflush valves and gauge P_f
- 13 External pressure accumulator
- 14 External pressure nozzle
- 15 Flushing channel (outside)
- 16 Cleaning valve (P3 control throttle)
- 17 Differential pressure contact gauge
- 18 P_1 gauge

3. Technical data

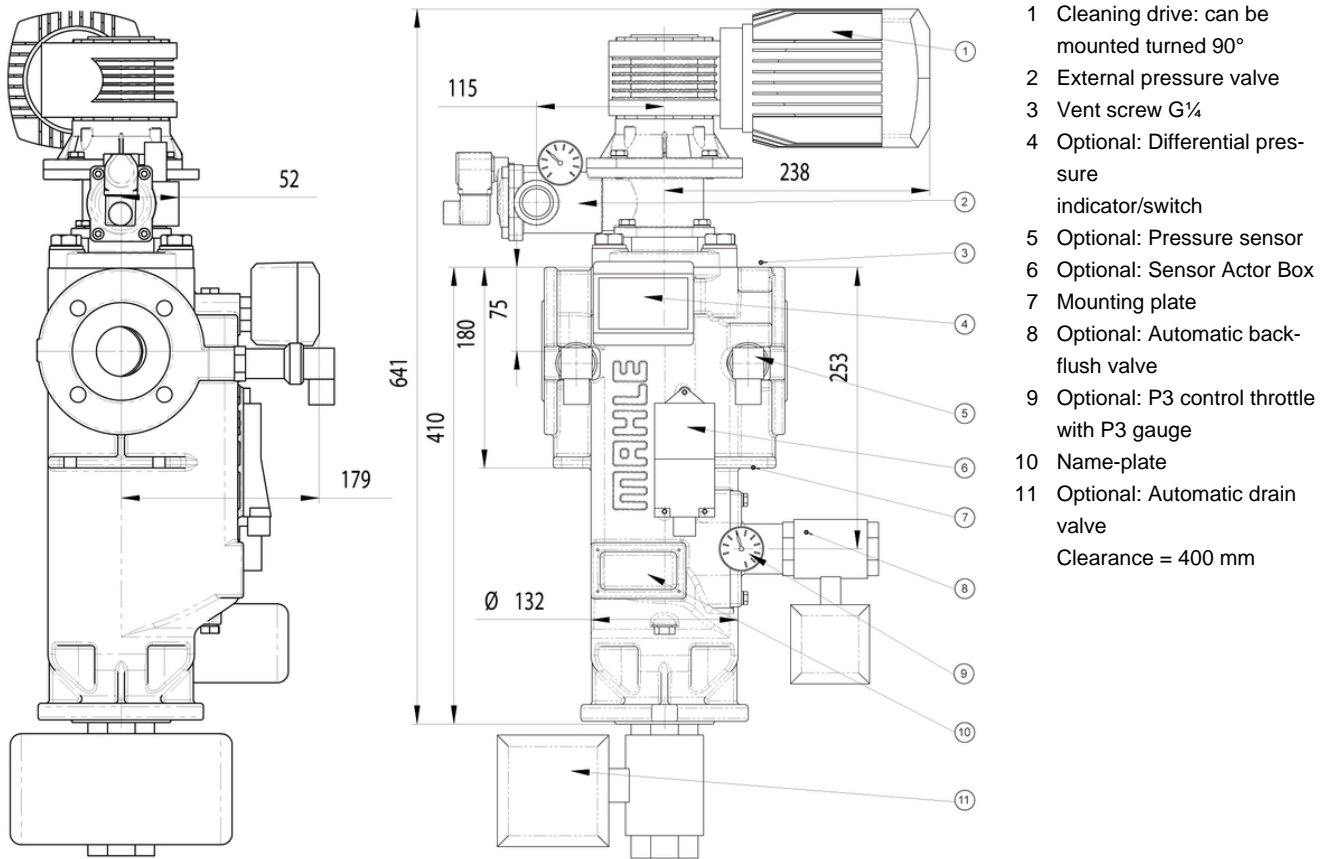

- 1 Cleaning drive: can be mounted turned 90°
 - 2 External pressure valve
 - 3 Vent screw G $\frac{1}{4}$
 - 4 Optional: Differential pressure indicator/switch
 - 5 Optional: Pressure sensor
 - 6 Optional: Sensor Actor Box
 - 7 Mounting plate
 - 8 Optional: Automatic backflush valve
 - 9 Optional: P3 control throttle with P3 gauge
 - 10 Name-plate
 - 11 Optional: Automatic drain valve
- Clearance = 400 mm

Filter data

- Max. operat. pressure: 16 bar
 Max. operat. temperature: 100 °C
 Materials:
- Housing and cover: cast iron
 - Internals: C-steel, PPS GF40
 - Bearing bushes: PTFE based
 - Seals: FPM (Viton)
 - Segmented element: 1.4571/Al (Δp max. 10 bar)
- Cover lock: 4 x M16 hexagon screws
- Connections and nominal diameters:
- A-inlet, B-outlet, C-drain: G $\frac{1}{2}$ threaded holes DIN 3852 form Z in flange DN 40
 - D-external pressure: G1 (must be reduced to G $\frac{1}{2}$ by the customer)
 - E-backflush: G1 accord. DIN 3852 form Z
 - F-gauge: G $\frac{1}{2}$ accord. DIN 3852 form Z
 - G-indicator: G1/8 accord. DIN 3852 form X
- Drive shaft seal: Lip seal with O-Ring
 External finish: Synthetic resin primer, blue acc. to RAL 5007

Motor data

Worm gear motor
 Multi-range winding

V	Hz	kW	U/min	A
Δ 230 \pm 10%	50	0,18	17	1,2
λ 400 \pm 10%	50	0,18	17	0,7
Δ 266 \pm 10%	60	0,22	17	1,1
λ 460 \pm 10%	60	0,22	17	0,7

Protection class: IP 55; insulation class F; output torque: 97 Nm

Optional:

- Ex protection acc. to ATEX 2014/34/EU
- Electrical components in Ex II 2G T3
- Mechanical design in Ex II 2G c T3
- Worm gear motor Ex, output torque: 97 Nm

Weight: 40 kg

Volume: 8 l

Differential pressure resistance

Segmented elements with topmesh: 10 bar

Other versions available on request.

Technical data is subject to change without notice!

4. Design and application

Element type (see section 6)	Total surface in cm ²	Filter rating in μm/ effective filter surface in cm ²								
		10	20	30	40	60	80	100	200	
AF 100XX4	437	310	310	310	310	310	310	310	310	310

 recommended design

Possible cleaning and discharge modes

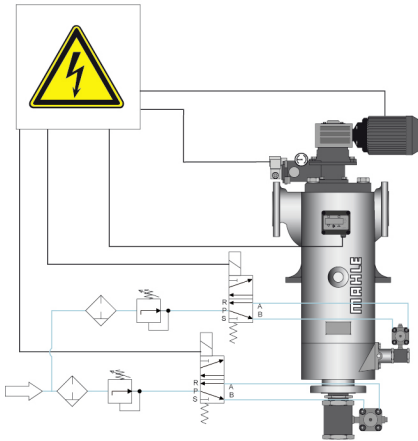

Fully automatic operation:

Filtration usually takes place under pressure. The filter is cleaned after a programmed time or a preset number of cycles or according to the differential pressure. We recommend cleaning the system at a differential pressure of approx. 0.5 - 0.7 bar. The cleaning motor is operated for around 3 s (about one turn of the element). The external pressure and cleaning valves remain open for this period. This suffices to clean the filter thoroughly.

The drain valve is opened in order to discharge the filter. Depending on the residue concentration, this can either take place directly after cleaning or be time or cycle controlled. The opening time of the drain valve is 2 bis 3 s.

Refer to the Instruction Manual for further information.

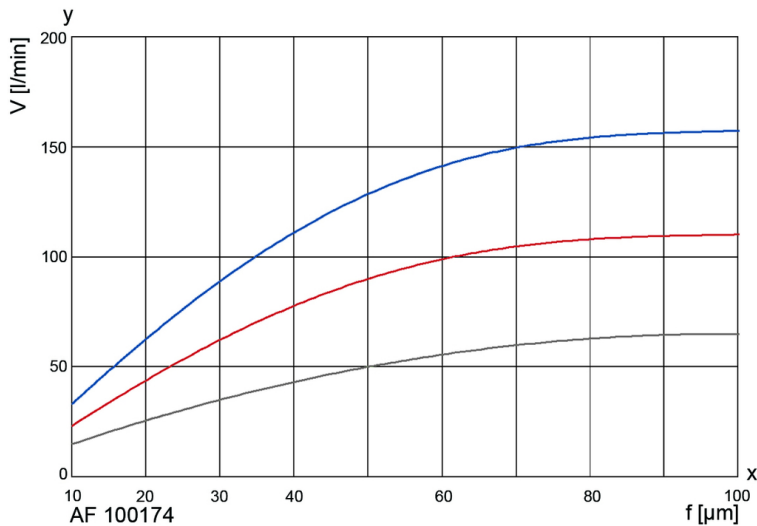

Filtration Group's team of specialists will be pleased to assist in any way. Tests can be carried out in the absence of reliable evaluation criteria.

5. Performance curves



The curves indicate the volume flow through the complete filter system (filter housing including element) and are referred to a differential pressure of 0.3 bar. Specific process information is essential to guarantee reliable operation of an automatic filter.

Viscosity in mm²/s

-  1 mm²/s
-  33 mm²/s
-  100 mm²/s

y = Volum flow V [l/min]

x = Filter rating f [μm]

6. Type number key

Type number key with selection example for AF 17243-221-43220/G2

Size

AF 1724 1 x 65x230 No. of steps x diameter x length [mm]

Cleaning drive

- 3 Gear motor 230/400 V, 50 Hz or 266/460 V, 60 Hz
- 4 Gear motor 230/400 V, 50 Hz Ex II 2G T3

Inlet and outlet connections

- 2 G1 1/2 in flange DN 40 PN16

Permissible operating pressure in bar (housing/cover)

- 2 PN 16

Material Seal FPM, bearing PTFE

- 1 Housing and cover nodular cast iron, internals steel, aluminium
- 3 Housing and cover nodular cast iron, internals stainless steel 1.4301/1.4571

Differential pressure indicator and gauge

- 1 PiS 3076, switching level at 1.2 bar, static 63 bar, aluminium/FPM
- 2 PiS 3076, switching level at 0.7 bar, static 63 bar, aluminium/FPM
- 4 PiS 3170, digital Δp -gauge, 2 switching levels settable from 0-16 bar

Valves and control throttles

- 3 External pressure valve G1 for liquid, 24 V DC
- 4 External pressure valve G1 for liquid, 230 V AC

Drain valve

- 2 Ball valve, electropneumatic 24 V DC
- 3 Ball valve, electropneumatic 230 V AC
- 4 Ball valve, electric 24 V DC
- 5 Ball valve, electric 230 V AC

Cleaning valve

- 2 Ball valve, electropneumatic 24 V DC
- 3 Ball valve, electropneumatic 230 V AC
- 4 Ball valve, electric 24 V DC
- 5 Ball valve, electric 230 V AC

Optional features

- 0 Without/special version

AF 1724 3 -2 2 1 -4 3 2 2 0 -XXXX (end number for special version)/G2*

*end number completion:

G2 cast iron, Version 2

End number	Special version
3001	Standard filter insert (complete), without housing or drive
3002	Standard filter insert (complete), without housing, with drive
3700	Seals PTFE
Other numbers	On request

Type number key with selection example for AF 100 element

Series

AF 100 Segmented element with topmesh (20 µm to 100 µm)

Material	Core element	Filter medium	Clamp rings
----------	--------------	---------------	-------------

Segmented element

17

Al

1.4571

St

Overall length Diameter x length in mm

4 65 x 230

Gap width/rating in µm (see 4. Design and application)

002	20 µm	004	40 µm	008	80 µm
003	30 µm	006	60 µm	010	100 µm

Other filter ratings on request

AF 100 17 4 - 006

7. Spare parts

No.	Designation	Material no.	
		FPM/C steel	PTFE/VA
1	Bush kit	70320691	
2	Set of seals (complete)	70376736	
3	Backflush channel moulding	70345207	
4	Backflush valve	70320084	
5	Filter element	See name-plate	

Please contact us for detailed technical information, any open questions about options, accessories and for general expert advice. Completion of the relevant questionnaire would facilitate in the coordination of all important parameters. Comprehensive documentation on our filter range, filter elements and accessories can be provided. About installation and operation, please refer to the Instruction Manual.

Filtration Group GmbH
 Schleifbachweg 45
 D-74613 Öhringen
 Phone +49 7941 6466-0
 Fax +49 7941 6466-429
 sales@filtrationgroup.com
 www.filtrationgroup.com
 70365279.01/2017