



Driven by performance

Low Pressure Filter Spin-on Cartridges HC/OC

Nominal pressure 10/16/25 bar (140/230/360 psi), nominal size up to 160

1. Features

High performance filters for modern hydraulic systems

- Modular design
- Compact design
- Minimal pressure drop through optimal flow design
- Quality filters, easy to service
- Equipped with highly efficient Mic or Sm-x filter elements
- Beta rated elements according to ISO 16889 multipass test
- Elements with high differential pressure stability and dirt holding capacity
- Worldwide distribution



2. Flow rate/pressure drop curve complete filter

■ 190 mm²/s
■ 33 mm²/s

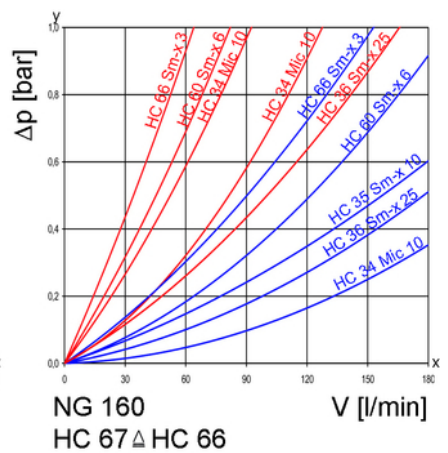
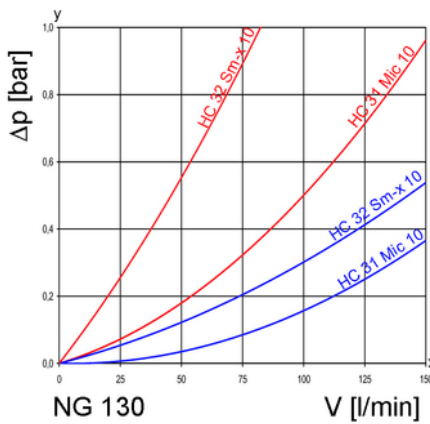
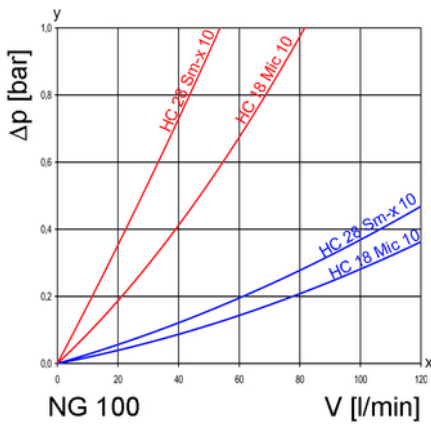
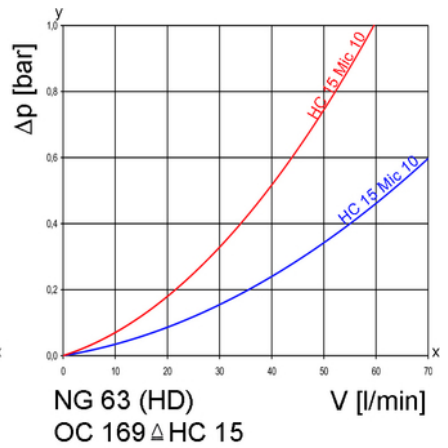
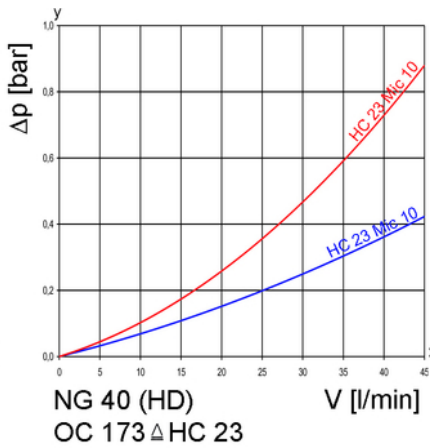
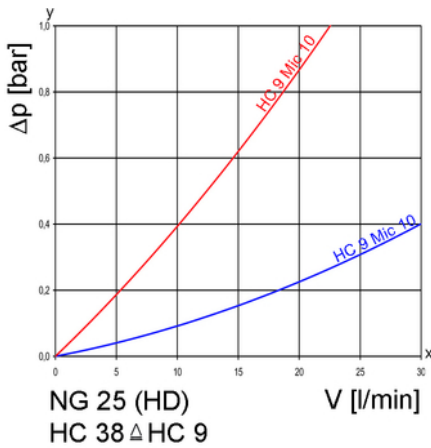
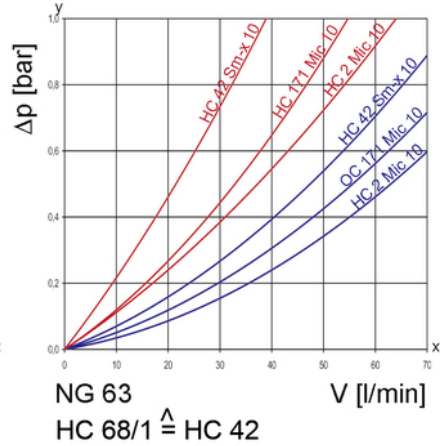
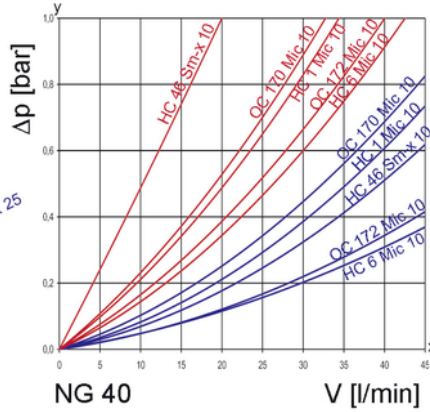
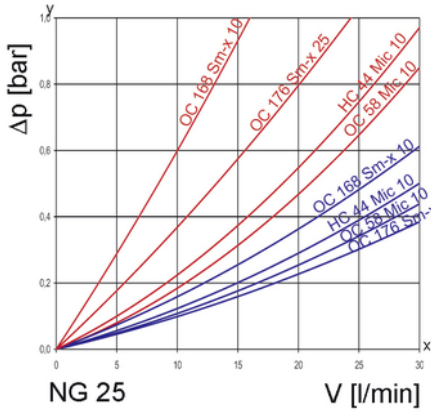

y = differential pressure Δp [bar]
 x = flow rate V [l/min]

3. Separation grade characteristics

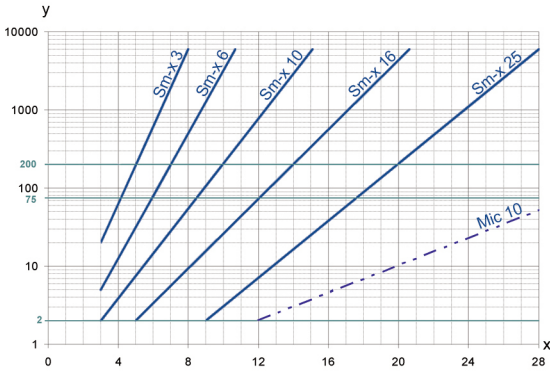

y = beta-value

x = particle-size [μm]

determined by multipass tests (ISO 16889)

calibration according to ISO 11171 (NIST)

4. Filter performance data

measured according to ISO 16889 (multipass test)

Sm-x elements with max. Δp 5 bar

Sm-x	3	$\beta_{5(C)}$	≥ 200
Sm-x	6	$\beta_{7(C)}$	≥ 200
Sm-x	10	$\beta_{10(C)}$	≥ 200
Sm-x	25	$\beta_{20(C)}$	≥ 200

values guaranteed up to 5 bar differential pressure

Subject to technical alteration without prior notice.

5. Quality assurance

MAHLE filters and filter elements are produced according to the following international standards:

Norm	Designation
DIN ISO 2941	Hydraulic fluid power; filter elements; verification of collapse/burst resistance
DIN ISO 2942	Hydraulic fluid power; filter elements; verification of fabrication integrity
DIN ISO 2943	Hydraulic fluid power; filter elements; verification of material compatibility with fluids
DIN ISO 3723	Hydraulic fluid power; filter elements; method for end load test
DIN ISO 3724	Hydraulic fluid power; filter elements; verification of flow fatigue characteristics
ISO 3968	Hydraulic fluid power filters; evaluation of pressure drop versus flow characteristics
ISO 10771.1	Fatigue pressure testing of metal containing envelopes in hydraulic fluid applications
ISO 16889	Hydraulic fluid power filters; multipass method for evaluation filtration performance of a filter element

6. Symbols

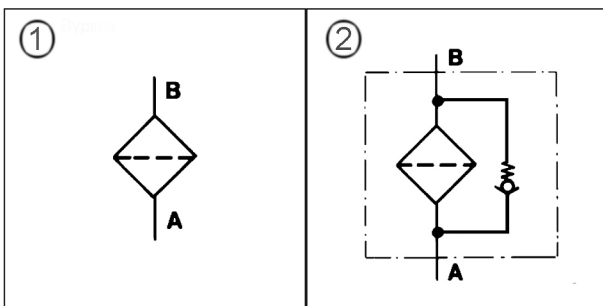

1. without bypass

2. with bypass

7. Order numbers

7.1 Housing design

Nominal size NG [l/min]	Order number	Type	Nominal pressure [bar]	Filter material	Filter surface [cm ²]	Bypass valve [bar]	Check valve
25	77785983	OC 58	10	Mic 10	1775		
	77500184	OC 168		Sm-x 10	1309		
	77785918	OC 176		Sm-x 25	1200		
	77500341	HC 44		Mic 10	1775	2.5	x
40	77640899	HC 1		Mic 10	3000		
	77844780	OC 170		Mic 10	3000	2.5	x
	77501273	HC 6		Mic 10	3000		
	77501232	HC 46		Sm-x 10	2075		
	71348143	OC 172		Mic 10	3000	2.5	x
63	72013241	HC 2		Mic 10	5440		
	77501372	HC 42		Sm-x 10	3360		
	72013027	OC 171		Mic 10	5440	2.5	x
100	77643331	HC 18		Mic 10	7000		
	77643398	HC 28		Sm-x 10	3400		
	77727183	HC 4		Mic 10	7260		
130	77500077	HC 31		Mic 10	9755		
	77500051	HC 32	Sm-x 10	5400			
160	77504194	HC 34	16	Mic 10	14025		
	78714750	HC 66		Sm-x 3	7638		
	77478829	HC 60		Sm-x 6	7638		
	77643844	HC 35		Sm-x 10	7638		
	77643851	HC 36		Sm-x 25	7638		
	78714768	HC 67	10	Sm-x 3	7638		
25	77373020	HC 9	25	Mic 10	2050	3.5	
	77503964	HC 38		Mic 10	2050		
40	77803257	OC 173		Mic 10	4100	2.5	
	77502180	HC 23		Mic 10	4100		
63	77502511	OC 169		Mic 10	5440	2.5	
	77502628	HC 15		Mic 10	5440		
	78787921	HC 68/1		Sm-x 3	3360		

8. Technical specifications

Nominal pressure:	10/16/25 bar (140/230/360 psi)
Temperature range:	- 10 °C to + 120 °C
Housing material:	steel
Sealing material:	perbunan
Opening pressure check valve:	≤ 0.12 bar
Installation:	preferably vertical
Collapse pressure of element:	$\Delta p \geq 5$ bar (70 psi)
Long time rupture strength:	min. 10^5 load alterations at nominal pressure

Spin-on cartridges are resistant against mineral oil.

We draw attention to the fact that all values indicated are average values which do not always occur in specific cases of application. Our products are continually being further developed. Values, dimensions and weights can change as a result of this. Our specialized department would be pleased to offer you advice.

We recommend to contact us concerning applications of our filters in areas governed by the EU directive 94/9 EG (ATEX 95). The standard version can be used for liquids based on mineral oil (corresponding to the fluids in Group 2 of Directive 97/23 EG Article 9). If you consider to use other fluids please contact us for additional support.

Subject to technical alteration without prior notice.

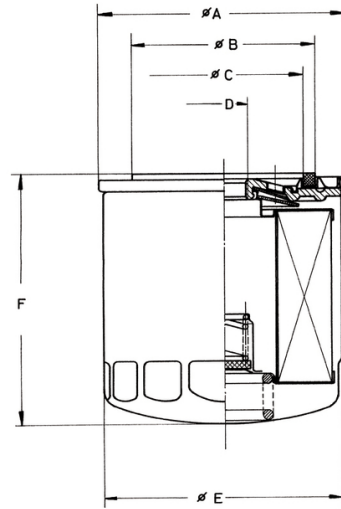

Figure shows spin-on cartridge with relief valve and check valve (optional).

9. Dimensions

All dimensions except "D" in mm.

Type	Ø A	Ø B	Ø C	D	Ø E	F	Weight [kg]
OC 58	80	72	62	¾" 16 UNF 2B	76	120	0.40
OC 168	80	72	62	¾" 16 UNF 2B	76	120	0.55
OC 176	80	72	62	¾" 16 UNF 2B	76	120	0.55
HC 44	80	72	62	¾" 16 UNF 2B	76	120	0.40
HC 1	95	72	62	¾" 16 UNF 2B	93	141	0.55
OC 170	95	72	62	¾" 16 UNF 2B	93	141	0.55
HC 6	95	72	62	1" 12 UNF 2B	93	141	0.55
HC 46	95	72	62	1" 12 UNF 2B	93	141	0.75
OC 172	95	72	62	1" 12 UNF 2B	93	141	0.55
HC 2	95	72	62	1" 12 UNF 2B	93	210	0.75
HC 42	95	72	62	1" 12 UNF 2B	93	210	0.75
OC 171	95	72	62	1" 12 UNF 2B	93	210	0.75
HC 18	143	111	100	1½" 16 UN 2B	136	172	1.50
HC 28	143	111	100	1½" 16 UN 2B	136	172	1.80
HC 4	143	111	100	G 1¼	136	172	1.50
HC 31	143	111	100	1½" 16 UN 2B	136	240	1.70
HC 32	143	111	100	1½" 16 UN 2B	136	240	2.20
HC 34	143	111	100	1½" 16 UN 2B	136	310	1.95
HC 66	143	111	100	1½" 16 UN 2B	136	310	2.65
HC 60	143	111	100	1½" 16 UN 2B	136	310	2.65
HC 35	143	111	100	1½" 16 UN 2B	136	310	2.65
HC 36	143	111	100	1½" 16 UN 2B	136	310	2.65
HC 67	143	111	100	G 1¼	136	310	2.65
HC 9	80	72	62	¾" 16 UNF 2B	76	140	0.55
HC 38	80	72	62	¾" 16 UNF 2B	76	140	0.55
OC 173	95	72	62	1" 12 UNF 2B	93	180	0.80
HC 23	95	72	62	1" 12 UNF 2B	93	180	0.80
OC 169	95	72	62	1" 12 UNF 2B	93	215	0.90
HC 15	95	72	62	1" 12 UNF 2B	93	215	0.90
HC 68/1	95	72	62	1" 12 UNF 2B	93	215	1.20

10. Accessories

All dimensions except "D" in mm.

Order number	Adapter			D	E	SW	F
	A	B	C				
77802382	32	15	12	¾" 16 UNF 2A	13	27	M18x1.5
77802390	35	15	15	1" 12 UNF 2A	17	27	M24x1.5
77893860	27	15	10	1" 12 UNF 2A	16	27	M22x1.5
77802408	35	15	15	1 ½" 16 UNF 2A	25	41	M38x1.5

The sealing surface for block mounting should be in accordance with ISO 6415.

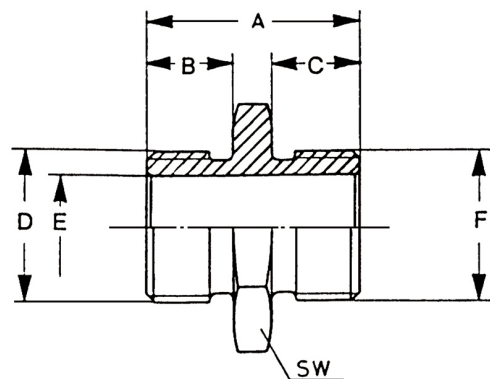

MAHLE Industriefiltration GmbH, Schleifbachweg 45, D-74613 Öhringen, Phone +49 7941 67-0

Fax +49 7941 67-23429, industrialfiltration@mahle.com, www.mahle.com

78356719.04/2015