

Technical Information

# Steering

## General, Steering Components



**Revision history**

*Table of revisions*

<b>Date</b>	<b>Changed</b>	<b>Rev</b>
July 2017	Updated literature number	0401
September 2015	Drawings updated	0400
September 2014	Mistakes corrected	DA
July 2014	Changed to Danfoss layout	CA
December 2009	Steering column deleted	BA
October 2002	First version	AA

**Contents**

**A wide range of steering components**

Conversion factors..... 7  
 Survey of literature with technical data on Danfoss steering components..... 7

**Steering concepts**

Hydrostatic steering..... 8  
     Steering units OSPM/OSPB/OSPC/OSPF/OSPR/OSPD/OSPU/OSPL..... 8  
     Flow-Amplifiers OSQA/OSQB ..... 9  
 Electrohydraulic steering system..... 9  
     Electrohydraulic steering..... 9

**Steering components, general**

Steering Units: OSPM, OSPB, OSPC, OSPR, OSPF, and OSPL..... 10  
 Steering unit with 2 rotary meters: OSPD..... 11  
 Steering unit with amplifier valve: OGPU..... 12  
 Priority valves: OLSA and OLS..... 13  
 Flow-Amplifiers: OSQA and OSQB..... 14  
 Steering valve EHPS..... 15  
 OSPE steering valve..... 16

**Steering components, product overview**

Variant explanations..... 17

**Steering components, main data and features**

OSPM mini steering units..... 19  
     The OSPM mini-steering unit is available in two versions:..... 19  
     Main data of OSPM..... 19  
     Features of OSPM:..... 19  
 OSPB, OSPC, OSPR, OSPD open center steering units..... 19  
 OSPB ON..... 19  
     Main data of OSPB ON:..... 20  
 OSPC ON/OR..... 20  
     Main data of OSPC ON:..... 20  
     Main data of OSPC OR:..... 20  
     Features of OSPB and OSPC Open center steering units:..... 20  
 OSPD ON/OR..... 21  
     Main data of OSPD ON:..... 21  
     Main data of OSPD OR..... 21  
     Features of OSPD open center steering units:..... 21  
 OSPB closed center steering units OSPB CN..... 21  
     Main data of OSPB CN:..... 22  
 OSPB,OSPC, OSPF, OSPR, OSPD, OSPQ, OSPL, load sensing steering units..... 22  
 OSPB LS and OSPC LS/LSR..... 22  
     The OSPB and OSPC Load Sensing steering unit is available in three versions:..... 22  
     Main data of OSPB LS and OSPC LS:..... 22  
     Main data of OSPC LSR:..... 22  
     Features of OSPB and OSPC load sensing steering units:..... 22  
 OSPF LS..... 23  
     Main data of OSPF LS: ..... 23  
     Features of OSPF load sensing steering units:..... 23  
 OSPD LS/LSR..... 23  
     Main data of OSPD LS:..... 23  
     Features of OSPD load sensing steering units:..... 23  
     Main data of OSPD LSR:..... 24  
 OGPU LS..... 24  
     Main data of OGPU LS:..... 24  
     Features of OGPU load sensing steering units:..... 24  
 OSPL LS..... 24  
     The OSPL load sensing steering unit is available in two versions:..... 25  
     Main data of OSPL LS:..... 25  
     Features of OSPL load sensing steering units:..... 25

**Contents**

OLSA/OLS priority valves.....25  
 The OLSA and OLS priority valves are available in two versions:..... 25  
 Main data of OLSA:.....25  
 Main data of OLS:.....26  
 Main data of OLSP:.....26  
 Features of OLSA and OLS priority valves:.....26  
 OSQ Flow Amplifier..... 26  
 The OSQ is available in three versions:..... 27  
 Main data of OSQ:.....27  
 Features of OSQ flow-amplifier:..... 27  
 Pilot steering units: OSPBX, OSPLX, OSPCX load sensing steering units..... 27  
 The "X LS" steering units are available in three versions:.....27  
 Main data of the "X LS" steering units:.....27  
 EHPS pilot operated steering valves.....28  
 EHPS type 0, hydrostatic steering system.....28  
 EHPS type 1, hydrostatic and electrohydraulic steering system.....28  
 EHPS type 2, hydrostatic and electrohydraulic steering system..... 29  
 Main data of EHPS:.....29  
 Features of EHPS:.....29  
 Pilot steering Unit OSPCX CN for EHPS..... 29  
 Main data of the OSPC CN steering units:.....29  
 OSPE steering valve.....30  
 Main data of OSPE.....30  
 Features of OSPE.....30  
 OVPL and OVR valve blocks.....30  
 Main data of OVPL.....30  
 Features of OVPL valve block..... 31

**Hydrostatic steering systems**

Open center steering system.....32  
 Load sensing steering systems..... 32  
 Features of load sensing static steering systems with Danfoss LS static steering units..... 32  
 Features of load sensing dynamic steering systems with Danfoss LS dynamic steering units.....33  
 Features of load sensing dynamic steering systems with Danfoss OSPF LS steering units..... 33

**Choice of steering concept and components**

Choice of steering concept and components..... 34  
 Legislation of steering systems.....34

**General Information**

Technical data common.....35  
 Manual steering pressure.....35  
 Demands on steering columns.....36  
 Steering components, main data and features..... 37  
 Calculation of steering systems..... 37  
 Ackermann steering..... 37  
 Cylinder..... 38  
 Calculation example of steering cylinder ..... 39  
 Calculation example of steering unit.....40  
 Calculation example of pump.....40  
 Steering wheel revolutions and steering speed.....40  
 Calculation of LS steering system with working hydraulics.....40  
 Calculation of steering system with flow-amplifier OSQA/OSQB.....41  
 Calculation of steering system for articulated vehicle.....41  
 Articulated vehicle.....42  
 Complete form.....42  
 Pump for flow-amplifiers OSQA/OSQB .....43  
 Oil types.....43  
 Particle content, degree of contamination and filtering.....44  
 Installation.....44  
 Tightening torques.....45

**Contents**

Starting up and running in.....	45
Maintenance.....	46
Information on labels.....	47
Examples of steering systems.....	47
OSPC ON .....	47
OSPC OR.....	48
OSPC LS + OLSA .....	48
OSPF + OLS.....	49
OSPD LS.....	49
OSPU LS.....	50
OSPBX LS and OSQA.....	51
2 x OSPBX LS and OSQB.....	52
OSPBX LS and OSQA shown with electrically driven pump for emergency steering.amplification during emergency steering.....	53
OSPCX LS and OSQB/OLSQ with integrated priority valve for emergency circuit.....	54
EHPS - type 1 steering valve with PVG 32, OSPCX pilot steering unit and PVRES joystick.....	55
EHPS - type 2 steering valve with control module PVED, OSPCX pilot steering unit and joystick.....	56
OSPE in system with variable pump and GPS steering.....	57
Load sensing steering system and load sensing working hydraulics with common oil supply from a fixed displacement pump.....	58

## A wide range of steering components



hfa1391605590092

Danfoss is one of the largest producers in the world of steering components for hydrostatic steering systems on off-road vehicles. Danfoss offers steering solutions both at component and system levels. Our product range makes it possible to cover applications of all types, ranging from ordinary 2 wheel steering (also known as Ackermann steering) to articulated steering, automatic steering (for example, by sensor) and remote controlled steering via satellite. We can offer more than 1,800 different steering units and 250 different priority valves categorized in types, variants and sizes.

### For hydrostatic steering systems, Danfoss offers:

- Mini steering units with displacements from 32 to 100 cm<sup>3</sup>/rev [1.95 to 6.10 in<sup>3</sup>/rev], flow up to 20 l/min [5.28 US gal/min], steering pressure up to 140 bar [2030 psi].
- Steering units with displacements from 40 to 1200 cm<sup>3</sup>/rev [2.44 to 73.2 in<sup>3</sup>/rev], flow up to 100 l/min [26.4 US gal/min], steering pressure up to 240 bar [3481 psi].
- Priority valves for rated flows at 40, 80, 120, 160 and 320 l/min [10.6, 21.1, 31.7, 42.3 and 84.5 US gal/min], pressure up to 350 bar [5076 psi].
- Pilot operated flow-amplifiers with amplification factors of 4, 5, 8, 10 or 20 for rated oil flows of 240 and 400 l/min [63.4 and 105.7 US gal/min], steering pressure up to 240 bar [3480 psi].
- Pilot operated steering valve with steering flow up to 100 l/min [26.4 US gal/min], steering pressure up to 250 bar [3625 psi] and with integrated priority valve for pump flow up to 120 l/min [31.7 US gal/min].

### For electrohydraulic steering systems Danfoss offers:

- Pilot operated steering valves (pilot operated by hydrostatic steering unit or by electrical signal) with steering flows up to 100 l/min [26.4 US gal/min], steering pressure up to 250 bar [3625 psi].
- Steering units with integrated electrical operated steering valve with steering flow up to 50 l/min [13.2 US gal/min], steering pressure up to 210 bar [3045 psi].
- Electrical operated steering valve with steering flow up to 70 l/min [18.5 US gal/min], steering pressure up to 210 bar [3045 psi].

### Characteristic features for steering units:

- Low steering torque: From 0.5 N·m to 3 N·m in normal steering situations
- Low noise level
- Low pressure drop

### A wide range of steering components

- Many types available: Open center Non-reaction, Open center Reaction, Power Beyond, Closed center Non-reaction, Load Sensing, Load Sensing Reaction
- One or more built-in valve functions: relief valve, shock valves, suction valves, non-return valve in P-line and in LS-line
- Optional port connections (according to ISO, SAE or DIN standards)

#### Characteristic features for electrohydraulic steering systems with OSPE, EHPS, and EHi:

- Possibility of GPS, row sensor, variable steering ratio and joystick steering
- The possibility of manual steering even on very heavy vehicles
- EHPS: High steering pressure requiring smaller cylinders and flow
- EHPS: Low pilot pressure and flow giving extremely low noise in the cabin
- EHPS: Can be combined with Danfoss PVG 32 proportional valve

### Conversion factors

1 N·m = [8.851 lbf·in]	1 l = [0.264 US gal]
1 N = [0.2248 lbf]	1 bar = [14.5 psi]
1 mm = [0.0394 in]	°F = [1.8°C + 32]
1 cm <sup>3</sup> = [0.061 in <sup>3</sup> ]	

### Survey of literature with technical data on Danfoss steering components

Detailed data on all Danfoss steering components and accessories can be found in our steering component catalogues, which is divided in to the following individual sub catalogues:

General information	Steering components
Technical data on mini steering units	OSPM
Technical data on open center, and closed center steering units	OSPB, OSPC, and OSPD
Technical data on load sensing steering units, priority valves and flow amplifiers	OSPB, OSPC, OSPF, OSPD, OSPL, OSPBX, OSPLX, OVPL, OLS and OSQ
Technical data on load sensing steering unit with amplification	OSPU
Technical data on hydraulic and electrohydraulic pilot operated steering valves, electrical actuation modules and appropriate steering units.	EHPS, EHPS w. OLS 320, PVE for EHPS and OSPCX
Technical data on combined steering unit/ electrohydraulic steering valves and steering wheel sensors	OSPE
Technical data on electrohydraulic steering valves	EHi
Technical data on steering wheel sensors	SASA

For technical information on individual variants, please contact the Danfoss Sales Organization.

## Steering concepts

### Hydrostatic steering

Danfoss steering components are used in vehicles where the driver has to control high steering forces, reliably, comfortably and with maximum safety.

#### Steering units OSPM/OSPB/OSPC/OSPF/OSPR/OSPD/OSPU/OSPL

The operation of Danfoss steering units OSP- is hydrostatic. That is to say, there is no mechanical connection between the steering column and the steered wheels.

Instead there are hydraulic pipes and hoses between steering unit and steering cylinder(s). When the steering wheel is turned, the steering unit meters out an oil volume proportional to the rate of rotation of the steering wheel. This volume is directed to the appropriate side of the steering cylinder, while simultaneously the displaced oil is directed to tank.

In open center systems the steering unit is supplied with oil from a separate pump with fixed displacement.

#### *Open center hydrostatic steering system*

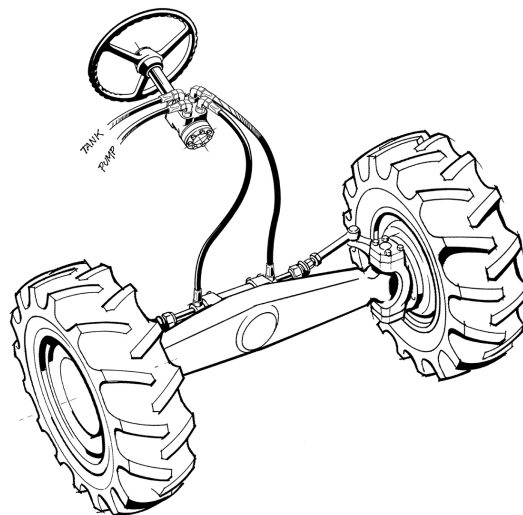

In load sensing (LS) systems one pump can supply oil to steering system and to working hydraulics. A priority valve ensures that steering always has first priority.

#### *Load sensing hydrostatic steering system*

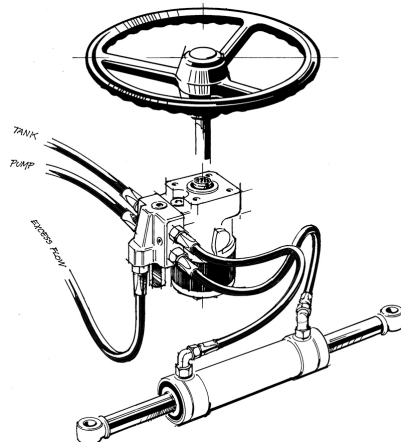



## Steering concepts

### Flow-Amplifiers OSQA/OSQB

In large vehicles and ships the steering units can be used with Danfoss Flow-amplifiers which amplify the oil flow to the steering cylinders. These systems with steering units and flow-amplifiers also include an inbuilt priority valve which ensures that the steering takes priority.

When the steering wheel is turned, the oil flow is divided in the flow-amplifier in such a way as to ensure that the necessary oil flow is led to the steering system.

The rest of the oil flow is available for the working hydraulics.

*Load sensing hydrostatic steering system with flow amplifier*

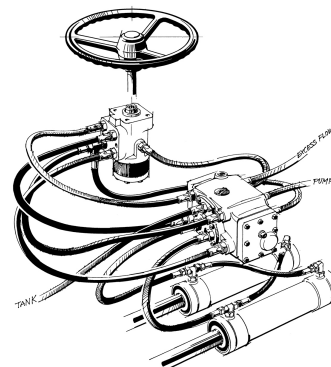

## Electrohydraulic steering system

### Electrohydraulic steering

On loaders, large forklift trucks, dumpers, heavy tractors, combine harvesters, maize harvesters and other similar machines there is often need for electrically actuated steering either in the form of a joystick, or fully automatic.

For this purpose Danfoss offers:

Combined steering unit and electro hydraulic steering valve, OSPE: **OSP** for normal manual steering wheel activated steering and **E** for electro hydraulic steering activated by electrical input signal either from GPS or vehicle controller or from steering wheel sensor (Danfoss type SASA) for variable steering ratio. In variable steering mode, the electro hydraulic valve part adds flow to the metered out flow from the steering unit part of the OSPE.

Pilot operated steering valve, EHPS: Electro Hydraulic Power Steering: A basic system (type 0) consists of a pilot steering unit as the signal source and an EHPS valve block which controls oil flow to the steering cylinders proportional to the pilot flow. The system can be extended to include an electrical actuator so that, as an alternative, it becomes possible to steer with a joystick (EHPS type 1). In addition, the valve block can be supplied with built-in micro controller and safety critical steering software (EHPS type 2). A steering system with EHPS type 2 means no steering wheel drift and possibility of variable steering ratio.

*Electrohydraulic steering system*

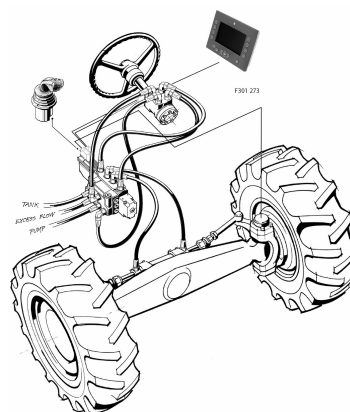

## Steering components, general

### Steering Units: OSPM, OSPB, OSPC, OSPR, OSPF, and OSPL

The steering unit consists of a rotary valve and a rotary meter.

Via a steering column the steering unit is connected to the steering wheel of the vehicle. When the steering wheel is turned, oil is directed from the steering system pump via the rotary valve (spool and sleeve) and rotary meter (gear wheel set) to the cylinder ports L or R, depending on the direction of turn. The rotary meter meters the oil flow to the steering cylinder in proportion to the angular rotation of the steering wheel. If the oil flow from the steering system pump is too small, the steering unit can function as a manual pump - assuming the conditions as described in [Manual steering pressure](#) on page 35.

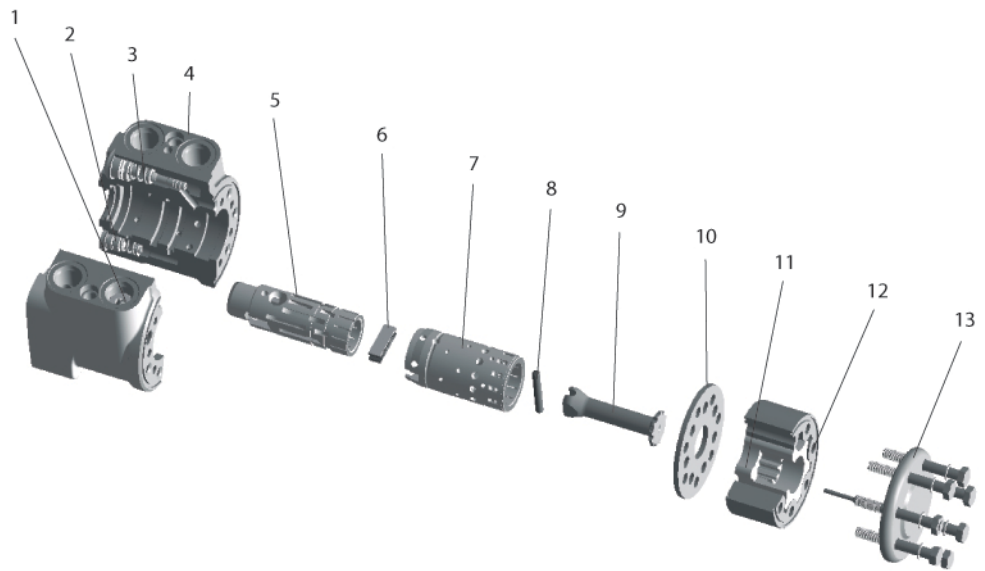

150-573.10

- |   |                                    |    |                   |
|---|------------------------------------|----|-------------------|
| 1 | Check valve                        | 8  | Cross pin         |
| 2 | Shock valve                        | 9  | Cardan shaft      |
| 3 | Relief valve                       | 10 | Distributor plate |
| 4 | Housing with anticavitation valves | 11 | Gear wheel        |
| 5 | Spool                              | 12 | Gear rim          |
| 6 | Neutral position spring            | 13 | End cover         |
| 7 | Sleeve                             |    |                   |

**Steering components, general**

**Steering unit with 2 rotary meters: OSPD**

The basic function of this type is like the main group of Danfoss steering units, except the gearwheel set (rotary meter). OSPD has 2 rotary meters, which are mechanically connected. A shift valve determines whether only one or both rotary meters are active. In the case of no pump supply only one rotary meter is active for emergency steering. In normal steering situations both rotary meters are active.

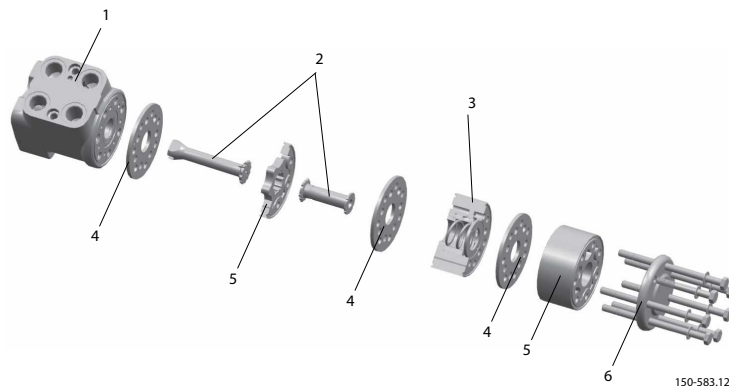

- |   |  |   |                    |
|---|--|---|--------------------|
| 1 | Housing with spool/sleeve set and valves | 4 | Distributor plates |
| 2 | Cardan shafts                            | 5 | Gear wheel sets    |
| 3 | Shift valve complete                     | 6 | End cover          |

**Steering components, general**

**Steering unit with amplifier valve: OSPU**

The basic function of this type is like the main group of Danfoss steering units, except the rotary valve and a torque compensator valve. The rotary valve (spool/sleeve set) of OSPU has an amplification function, which adds flow directly to the cylinder ports in parallel with oil passing through the rotary meter (gear wheel set). In the case of no pump supply (emergency steering) only the gear wheel set meters oil to the cylinder ports. The function of the torque compensator valve is to assure constant amplification.

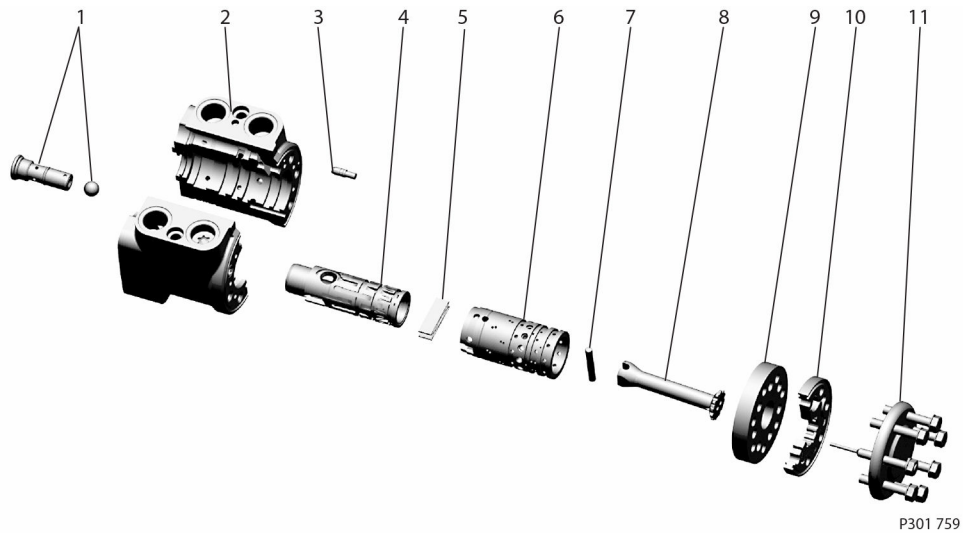

P301 759

- |   |                           |    |                   |
|---|---------------------------|----|-------------------|
| 1 | Amplification valve parts | 7  | Cross pin         |
| 2 | Housing with valve parts  | 8  | Cardan shaft      |
| 3 | LS copy valve             | 9  | Distributor plate |
| 4 | Spool                     | 10 | Gear wheel set    |
| 5 | Neutral position spring   | 11 | End cover         |
| 6 | Sleeve                    |    |                   |

## Steering components, general

### Priority valves: OLSA and OLS

In systems with Danfoss priority valves and load sensing steering units, steering has first priority. When the steering wheel is turned, the oil flow is distributed in the priority valve in such a way that the oil flow necessary for steering is led to the steering unit through the CF (controlled flow) connection. The remaining oil flow is available for the working hydraulics through the EF (excess flow) connection.

The distribution is controlled by the LS signal from the steering unit, so that the oil flow to the steering unit is always determined by the actual steering rate.

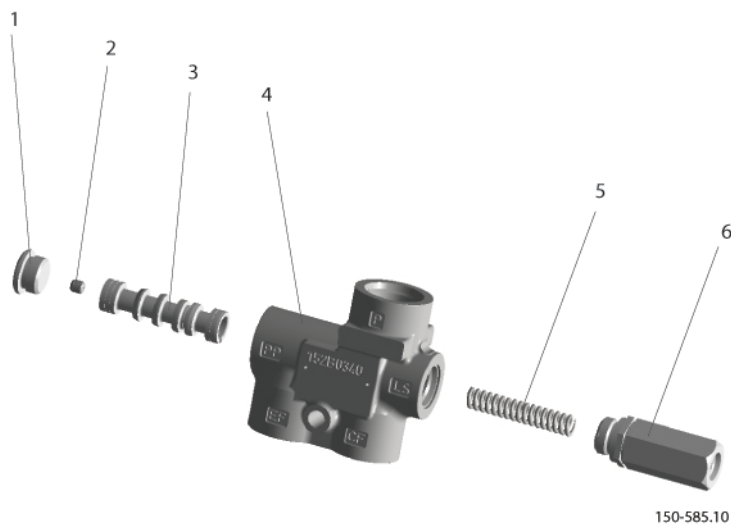

- 1 Plug
- 2 Damping orifice (PP)
- 3 Spool

- 4 Housing
- 5 Spring
- 6 LS-plug with LS-orifice

## Steering components, general

### Flow-Amplifiers: OSQA and OSQB

The flow-amplifiers OSQA and OSQB contain a directional valve, an amplification valve, a priority valve, a pilot pressure relief valve, shock and suction valves.

In addition OSQB contains a back pressure valve. The flow-amplifier amplifies the oil flow from the steering unit cylinder ports L or R by an amplification factor of 4, 5, 8, 10 or 20.

The amplified oil flow is directed from the flow-amplifier ports CL or CR to the steering cylinder(s). The amplified flow is proportional to the rate of the steering wheel rotation. If the oil flow from the pump fails, the flow-amplifier cuts off the amplification and manual steering through the steering unit is possible under the same conditions as those mentioned in the section: [Manual steering pressure](#) on page 35.

The pressure drop through the flow-amplifier at manual steering is about 5 bar [72.5 psi].

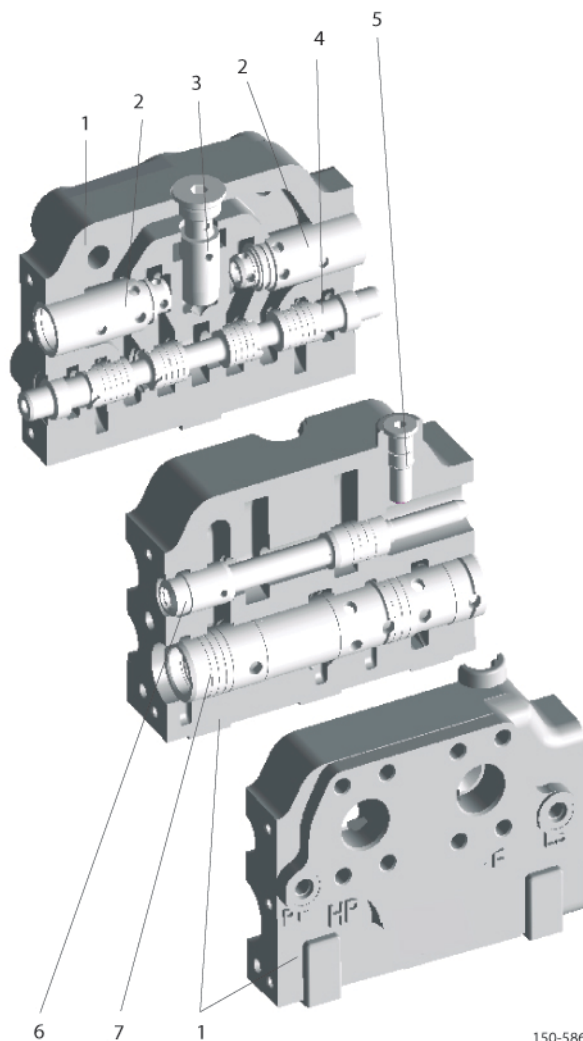

150-586.10

- |   |                          |   |                             |
|---|--------------------------|---|-----------------------------|
| 1 | Housing                  | 5 | Pilot pressure relief valve |
| 2 | Shock and suction valves | 6 | Priority valve              |
| 3 | Back pressure valve      | 7 | Amplification valve         |
| 4 | Directional spool        |   |                             |

## Steering components, general

### Steering valve EHPS

The EHPS is a pilot operated directional valve. Oil from a pilot steering unit or an electrical signal can actuate the steering valve.

Basically the EHPS valve contains a directional valve, a priority valve, a pilot relief valve, a pilot pressure control valve, and shock- and suction valves.

An electric actuation module, PVE, can be fitted onto the EHPS valve. In the type 1 system the controller is operated by an analog signal and the type 2 system the signal is digital with Canbus interface and it comprises a micro processor with safety critical steering software.

The pilot for the directional valve in EHPS can be supplied either by the flow from steering unit (cylinder port L or R), or by the flow from the electric actuation module PVE/PVED.

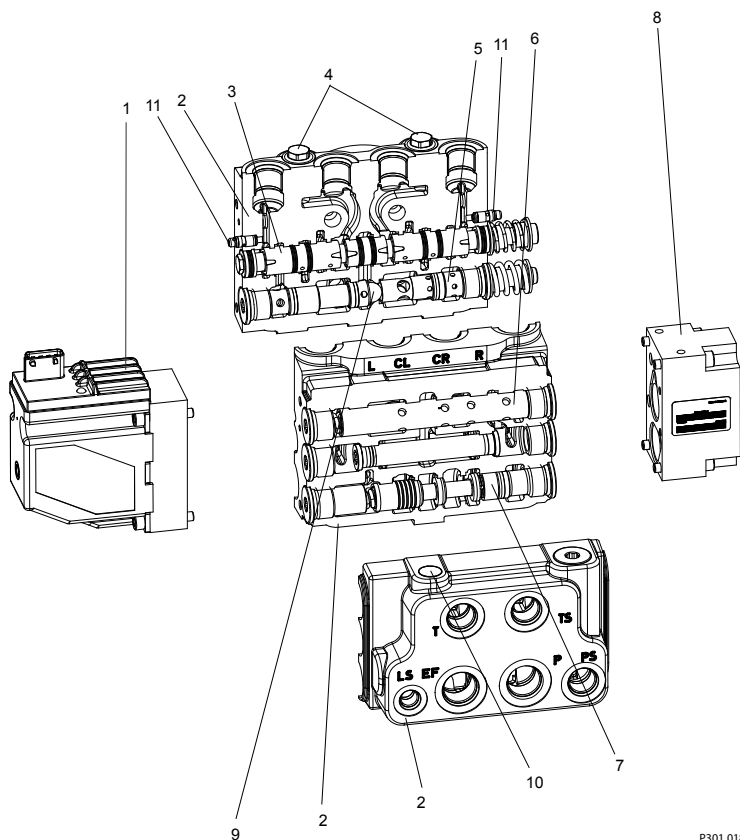

P301 018

1	Electrical actuation module PVE/PVED	6	Pilot pressure valve for electrical actuating module
2	Housing	7	Priority valve
3	Directional spool	8	Cover
4	Shock and suction valve	9	Emergency steering valve
5	Pilot pressure reduction valve for steering unit	10	Pilot pressure relief valve
		11	Shuttle valves

## Steering components, general

### OSPE steering valve

OSPE with an electrical programmable module (PVED-CL) the following steering features in electro hydraulic steer mode/field mode are possible:

- GPS-steering
- Row sensor/ camera steering
- Joy stick or mini st. wheel steering
- Variable steering ratio
- Speed depending steering ratio

This block diagram shows all input devices possible for the PVED-CL actuator/controller. Detailed description is to be found in separate literature, PVED-CL User Manual, please contact Danfoss Sales Organization.

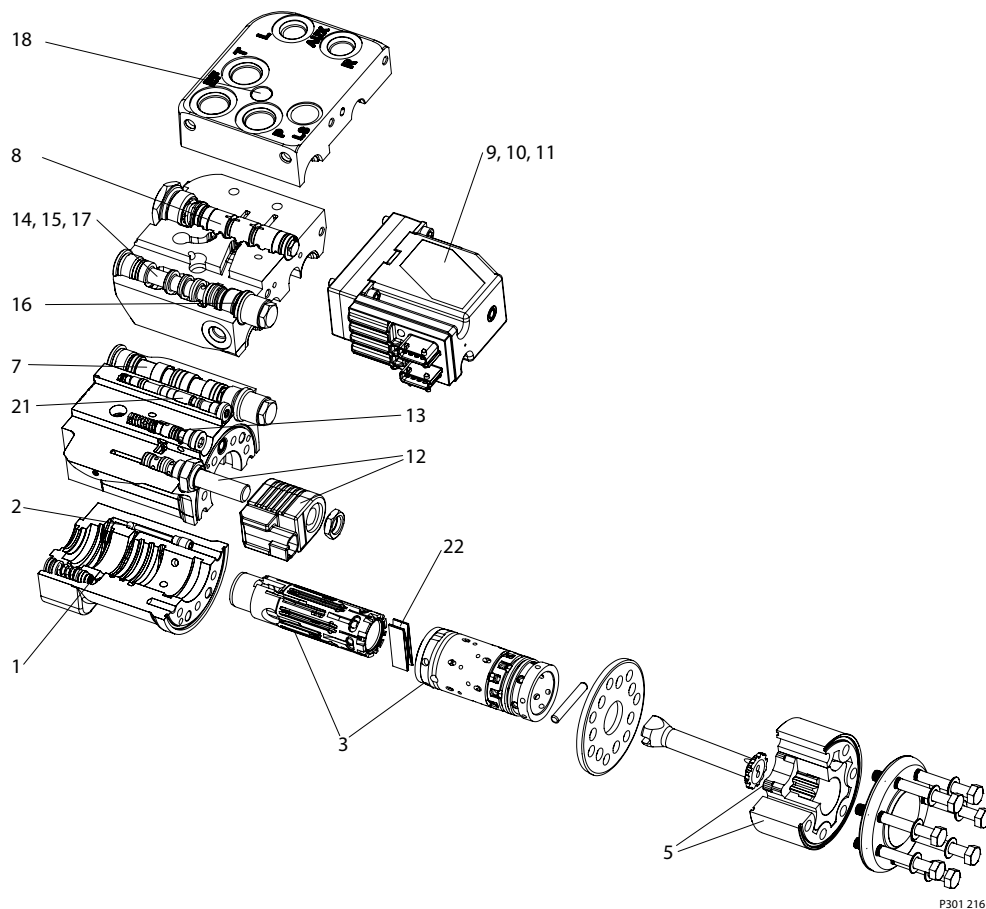

1	Shock valves	12	Control valve for mode select
2	Suction valves	13	Pilot reduction valve, 12 bar
3	Spool/sleeve set	14	PP damping orifice
5	Gear set	15	Priority valve spool
7	Mode select and EH cut off valve	16	Priority valve spring
8	EH directional valve	17	Dynamic orifice
9	PVE control unit	18	Pilot pressure relief valve
10	LVDT transducer	21	PVFC valve/LS resolver
11	Solenoid valve bridge	22	Neutral spring package for spool/sleeve



### Steering components, product overview

Type	Variants	Description
<b>Steering units</b>		
OSPM	ON, PB	Mini steering unit for smaller vehicles
OSPB	ON, CN, LS,	Steering unit with no valve functions
OSPC	ON, OR, ORM, LS, LSd, LSR, LSRd, LSRMd	Steering unit with valve functions
OSPF	LSd	Steering unit full drain dynamic load sensing and with valve functions
OSPD	ON, LSd, LSRd	Steering unit with 2 displacements and with valve functions
OSPU	LSd	Steering unit with flow amplification and with valve functions
OSPL	LS, LSd	Steering unit for larger vehicles
OSPBX	LS	Pilot steering unit for OSQ static
OSPLX	LS	Pilot steering unit for OSQ static
OSPCX	LSd	Pilot steering unit for OSQ dynamic
OSPCX	CN	Pilot steering unit for EHPS
<b>Priority valves</b>		
OLSA	LS, LSd	Priority valve for flanging on steering unit
OLS	LS, LSd	Priority valve for in line use
<b>Flow-Amplifiers</b>		
OSQA	LS	Flow-amplifier
OSQB	LS	Flow-amplifier with back pressure valve
OSQB/OLSQ	LSd	Flow-amplifier with priority valve for emergency circuit
<b>Steering valve</b>		
EHPS type 0	LSd	Pilot operated steering valve
<b>Electrohydraulic power steering</b>		
EHPS type 1	LSd	Pilot operated steering valve with electrical actuation module
EHPS type 2	LSd	Pilot operated steering valve with programmable electrical actuation module
OSPE	LSd, LSRMd	Combined steering unit/electrohydraulic steering valve
<b>Valve blocks</b>		
OVPL	-	Valve block for OSPL
OVR	-	Angular block for side ported steering units

### Variant explanations

- **ON:** Open center Non-reaction
- **LS:** Load Sensing, static
- **OR:** Open center Reaction
- **ORM:** Open center Reaction RM-technology

### Steering components, product overview

- **LSd:** Load Sensing, dynamic
- **CN:** Closed center Non-reaction
- **LSR:** Load Sensing Reaction, static
- **PB:** Power Beyond LSRd: Load Sensing Reaction, dynamic
- **LSRMd:** Load Sensing Reaction RM-technology, dynamic

## Steering components, main data and features

### OSPM mini steering units

For light vehicles such as garden tractors, municipal vehicles, lawn mowers, small fork lift trucks, etc., Danfoss offers OSPM hydrostatic steering units.



#### The OSPM mini-steering unit is available in two versions:

- Open center Non-reaction (ON)
- Power Beyond (PB), where surplus oil can be led to working hydraulics.

#### Main data of OSPM

- Displacement: 32 - 100 cm<sup>3</sup>/rev [1.95 - 6.10 in<sup>3</sup>/rev]
- Flow, recommended: 3 - 20 l/min [0.79 - 5.28 US gal/min]
- Maximum steering pressure: 125 bar [1812 psi]
- Maximum back pressure (T): 20 bar [290 psi]

#### Features of OSPM:

- Small dimensions and low weight
- Low steering torque 0.5 to 1.5 N·m [4.43 to 13.28 lbf·in]
- One or more built-in valve functions: pressure relief, shock in L + R (servo ports Left and Right) and / or non return in P (Pump connection)
- End ports with integrated fittings (ORFS): O-ring face seal
- Possibility of integrated steering column

### OSPB, OSPC, OSPR, OSPD open center steering units

For small to large vehicles typically tractors, harvesters, fork lifts, contractors machines and special vehicles, etc., Danfoss offers a wide range of hydrostatic steering units.

For open circuit systems, where a separate fixed displacement pump is supplying the steering system with oil the following types of Danfoss steering units are suitable:

- OSPB, OSPC, OSPR and OSPD

### OSPB ON

The OSPB Open center steering unit is available in one version:

- Open center Non-reaction (ON)

## Steering components, main data and features

### Main data of OSPB ON:

- Displacement: 50 - 500 cm<sup>3</sup>/rev [3.05 - 30.5 in<sup>3</sup>/rev]
- Flow, recommended: 5 - 70 l/min [1.32 - 18.5 US gal/min]
  - Maximum steering pressure: 210 bar [3045 psi]
  - Maximum back pressure: 40 bar [580 psi]



### OSPC ON/OR

The OSPC Open center steering unit is available in two versions:

- Open center Non-reaction (ON)
- Open center Reaction (OR)



### Main data of OSPC ON:

- Displacement: 40 - 500 cm<sup>3</sup>/rev [2.44 - 30.51 in<sup>3</sup>/rev]
- Flow, recommended: 4 - 70 l/min [1.06 - 18.49 US gal/min]
- Maximum steering pressure: 210 bar [3045 psi]
- Maximum back pressure: 40 bar [580 psi]

### Main data of OSPC OR:

- Displacement: 40 - 200 cm<sup>3</sup>/rev [2.44 - 12.21 in<sup>3</sup>/rev]
- Flow, recommended: 4 - 50 l/min [1.06 - 13.21 US gal/min]
- Maximum steering pressure: 210 bar [3045 psi]

### Features of OSPB and OSPC Open center steering units:

- Low steering torque 0.8 to 3.0 N·m [7.08 to 26.6 lbf·in] in normal steering situations due to low effort springs and wide control range.
- Low noise due to laminar flow conditions throughout profile-grinded passages.
- OSPC: one or several built in valve functions: pressure relief, shock in L + R, suction in L + R and / or non-return in P.

## Steering components, main data and features

### OSPD ON/OR

The OSPD Open center steering unit is available in two version:

- Open center Non-reaction (ON) version
- Open center Reaction (OR) version



#### Main data of OSPD ON:

- Displacement :
  - From 60 cm<sup>3</sup>/rev to max 125 cm<sup>3</sup>/rev [3.66 to max. 7.63 in<sup>3</sup>/rev] during manual steering without pump oil supply and with one rotary meter active.
  - From 185 cm<sup>3</sup>/rev up to 440 cm<sup>3</sup>/rev [11.3 up to 26.9 in<sup>3</sup>/rev] at full oil supply and with both rotary meters active.
- Flow, recommended: 19 - 70 l/min [5.02 - 18.49 US gal/min]
- Maximum steering pressure: 210 bar [3045 psi]
- Maximum back pressure: 40 bar [580 psi]

#### Main data of OSPD OR

- Displacement:
  - 60 cm<sup>3</sup>/rev or 70 cm<sup>3</sup>/rev [3.66 in<sup>3</sup> or 4.27 in<sup>3</sup>/rev] during manual steering
  - From 185 cm<sup>3</sup>/rev up to 220 cm<sup>3</sup>/rev [11.28 up to 13.42 in<sup>3</sup>/rev] at full oil supply
- Flow recommended: 12 - 50 l/min [3.17 - 13.21 US gal/min]
- Maximum steering pressure: 210 bar [3045 psi]
- Maximum back pressure: 40 bar [580 psi]

#### Features of OSPD open center steering units:

- Features like OSPC Open center steering units plus:
  - Possibility of manual steering of heaviest vehicles, without the need for an emergency pump.

### OSPB closed center steering units OSPB CN

For constant-pressure systems with variable pump flow Danfoss offers the steering unit types: OSPB CN

The OSPB closed center steering unit is available in one version:

- Closed center Non-reaction (CN)



## Steering components, main data and features

### Main data of OSPB CN:

- Displacement: 50 - 400 cm<sup>3</sup>/rev [3.05 - 24.4 in<sup>3</sup>/rev]
- Flow: 5 - 50 l/min [1.32 - 13.20 US gal/min]
- Maximum steering pressure: 175 bar [2538 psi]
- Maximum back pressure: 40 bar [580 psi]

## OSPB,OSPC, OSPF, OSPR, OSPD, OSPQ, OSPL, load sensing steering units

For small to large vehicles typically tractors, harvesters, fork lifts, contractors machines and special vehicles, etc., Danfoss also offers a wide range of hydrostatic steering units of the Load Sensing (LS) types: OSPB, OSPC, OSPF, OSPD, and OSPQ LS steering units are for Load Sensing systems, where oil is supplied by a pump via a priority valve or from a pump with variable displacement.



## OSPB LS and OSPC LS/LSR

### The OSPB and OSPC Load Sensing steering unit is available in three versions:

- Load Sensing non-reaction (LS) static
- Load Sensing non-reaction (LS) dynamic
- Load Sensing Reaction (LSR) dynamic (only OSPC)

### Main data of OSPB LS and OSPC LS:

- Displacement: 40 - 400 cm<sup>3</sup>/rev [2.44 - 24.4 in<sup>3</sup>/rev]
- Flow: 4 - 40 l/min [1.06 - 10.57 US gal/min]
- Maximum steering pressure: up to 210 bar [3045 psi]
- Maximum back pressure: 40 bar [580 psi]

### Main data of OSPC LSR:

- Displacement: 40 - 200 cm<sup>3</sup>/rev [2.44 - 12.20 in<sup>3</sup>/rev]
- Flow: 4 - 20 l/min [1.06 - 5.28 US gal/min]
- Maximum steering pressure: 210 bar [3045 psi]
- Maximum back pressure: 40 bar [580 psi]

### Features of OSPB and OSPC load sensing steering units:

- Low steering torque 0.8 to 3.0 N•m [ 7.08 to 26.55 lbf•in] in normal steering situations
- Low noise
- OSPC: one or several built in valve functions: pilot pressure relief, shock in L + R, suction in L + R and/or non-return in P. OSPC LS/LSR Dynamic: non-return valve in LS-connection.

## Steering components, main data and features

### OSPF LS

The OSPF Load Sensing steering unit is available in one version:

- Full drain Load Sensing non-reaction (LS) dynamic



#### Main data of OSPF LS:

- Displacement: 80 - 400 cm<sup>3</sup>/rev [4.88 - 24.4 in<sup>3</sup>/rev]
- Flow: 8 - 40 l/min [2.11 - 10.57 US gal/min]
- Maximum steering pressure: 210 bar [3045 psi]
- Maximum back pressure: 40 bar [580 psi]

#### Features of OSPF load sensing steering units:

- Low steering torque 0.5 to 1.8 N·m [4.43 to 15.93 lbf·in] in normal steering situations
- Low noise and wide control range
- Higher maximum steering speed, limited only by the capacity of the pump and the pressure setting
- One or several built in valve functions: pilot pressure relief, shock in L + R, suction in L + R and / or non-return in P.

### OSPD LS/LSR

The OSPD Load Sensing steering unit is available in two versions:

- Load Sensing non-reaction (LS) dynamic
- Load Sensing Reaction (LSR) dynamic



#### Main data of OSPD LS:

- Displacement :
  - From 60 cm<sup>3</sup>/rev to max 125 cm<sup>3</sup>/rev [3.66 to max. 7.63 in<sup>3</sup>/rev] during manual steering without oil supply and with one rotary meter active.
  - From 185 cm<sup>3</sup>/rev up to 440 cm<sup>3</sup>/rev [11.28 up to 26.9 in<sup>3</sup>/rev] at full oil supply and with both rotary meters active.
- Flow: 19 - 44 l/min [5.02 - 11.62 US gal/min]
- Maximum steering pressure: 210 bar [3045 psi]
- Maximum back pressure: 40 bar [580 psi]

#### Features of OSPD load sensing steering units:

- Features like OSPC LS plus :

### Steering components, main data and features

- Possibility of manual steering of heaviest vehicles, without the need for an emergency pump.

#### Main data of OSPD LSR:

- Displacement :
  - From 60 or 70 cm<sup>3</sup>/rev [3.66 or 4.27 in<sup>3</sup>/rev] during manual steering
  - From 185 to 220 cm<sup>3</sup>/rev [11.28 to 13.42 in<sup>3</sup>/rev] at full oil supply
- Flow: 19 - 22 l/min [5.02 - 5.81 US gal/min]
- Maximum steering pressure: 210 bar [3045 psi]
- Maximum back pressure: 40 bar [580 psi]

### OSPU LS

The OSPU Load Sensing steering unit is available in one version:

- Load Sensing non-reaction (LS) dynamic with build in amplification function



#### Main data of OSPU LS:

- Displacement :
  - From 60 to 125 cm<sup>3</sup>/rev [3.66 to 7.63 in<sup>3</sup>/rev] during manual steering without pump oil supply
  - From 120 to 500 cm<sup>3</sup>/rev [7.32 to 30.51 in<sup>3</sup>/rev] at normal pump supply. Amplification factors 2, 3 or 4 linear or 2 progressive.
- Flow: 8 - 50 l/min [2.11 - 13.21 US gal/min]
- Maximum steering pressure: 210 bar [3045 psi]
- Maximum back pressure: 40 bar [580 psi]

#### Features of OSPU load sensing steering units:

- Features like OSPC LS plus
  - Possibility of manual steering of heavier vehicles, without the need for an emergency pump
  - Possibility of “Fast Steer” with progressive amplification

### OSPL LS

For larger vehicles typically heavy fork lift trucks, loaders and dumpers, Danfoss also offers a hydrostatic steering units of the Load Sensing (LS) type optimized for high steering flow: OSPL.



F300 611



## Steering components, main data and features

### The OSPL load sensing steering unit is available in two versions:

- Load Sensing non-reaction (LS) static
- Load Sensing non-reaction (LS) dynamic

### Main data of OSPL LS:

- Displacement : 520 - 1200 cm<sup>3</sup>/rev [31.8 - 73.2 in<sup>3</sup>/rev]
- Flow: 52 - 100 l/min [13.74 - 26.4 US gal/min]
- Maximum steering pressure: 240 bar [3480 psi]
- Maximum back pressure: 40 bar [580 psi]

### Features of OSPL load sensing steering units:

- Low steering torque 0.8 to 3.0 N·m [7.08 to 26.6 lbf·in] in normal steering situations
- Low noise
- Low pressure drop even at high flow
- Possibility of built in valve function: pilot pressure relief valve. The OSPL valve block for OSPL contains shock L + R, suction L + R, non-return in pump line and / or back pressure valve in tank connection.

## OLSA/OLS priority valves

For Load Sensing systems, Danfoss offers a wide range of priority valves:

Priority valves for flang mounting to Danfoss LS-Steering units:  
 OLSA (Except for OSPR, OSPQ and OSPL)  
 Priority valves for in-line use: OLS

OLSA



### The OLSA and OLS priority valves are available in two versions:

- Static and
- Dynamic

OLS 40/80



### Main data of OLSA:

- Flow, rated: 40 or 80 l/min [10.57 - 21.1 US gal/min]
- Maximum system pressure: 250 bar [3625 psi]

OLS 120



**Steering components, main data and features**

**Main data of OLS:**

- Flow, rated: 40, 80, 120, 160 or 320 l/min [10.57, 21.1, 31.7, 42.3 or 84.5 US gal/min]
- Maximum system pressure: 250 bar [3625 psi]
  - OLS 160: 350 bar [5076 psi] on P and EF port

OLS 160



**Main data of OLSP:**

- Flow, rated: 80 l/min [21.1 US gal/min]
- Maximum system pressure: 250 bar [3625 psi]

OLSP



**Features of OLSA and OLS priority valves:**

- Low noise valves
- OLS 160 and OLS 320: available with pilot pressure relief valve

OLS 320



**OSQ Flow Amplifier**

For very heavy vehicles typically very large fork lift trucks, loaders, dumpers and special vehicles weighing one hundred ton or more, Danfoss offers a flow-amplifier to amplify the oil from the steering unit: OSQ. The OSQ is based on the load sensing steering principle.

OSQB

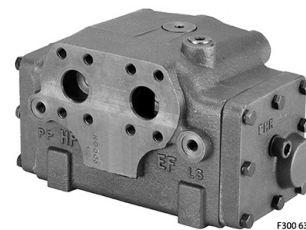

## Steering components, main data and features

### The OSQ is available in three versions:

- OSQA for normal fittings connection
- OSQB with back pressure valve in tank connection and for flange type fittings
- OSQB/OLSQ with priority valve for emergency steering circuit

OSQB/OLSQ



### Main data of OSQ:

- Amplification factors : 4, 5, 8,10 or 20
- Total displacement of steering system: 640 - 4160 cm<sup>3</sup>/rev [39 - 254 in<sup>3</sup>/rev]
- Flow: OSQA: 240 l/min [63.4 US gal/min] OSQB: 400 l/min [105.7 US gal/min]
- Maximum steering pressure: 210 bar [3045 psi]

### Features of OSQ flow-amplifier:

- High steering capacity
- Low pressure drop even at high flow
- Possibility of built in valve functions: pilot pressure relief valve, priority valve, shock and suction valves in L + R. OSQB also has back pressure valve in tank connection.
- OSQB/OLSQ has flanged on priority valve for emergency steering circuit

## Pilot steering units: OSPBX, OSPLX, OSPCX load sensing steering units

The OSQ flow-amplifiers require special pilot steering units of the type

- OSPBX LS
- OSPLX LS or
- OSPCX LS

which are all load-sensing steering units whose L- and R- connections are open to tank in neutral position.

OSPBX LS



### The "X LS" steering units are available in three versions:

- OSPBX LS for OSQA and OSQB
- OSPLX LS for OSQA and OSQB
- OSPCX LS with pilot pressure relief valve for OSQB/OLSQ

### Main data of the "X LS" steering units:

Displacement OSPBX LS and OSPCX LS 160 - 400 cm<sup>3</sup>/rev [9.76 - 24.4 in<sup>3</sup>]

Displacement OSPLX LS 520 - 630 cm<sup>3</sup>/rev [31.7 - 38.4 in<sup>3</sup>]

Maximum steering pressure 210 bar [3045 psi]

## Steering components, main data and features

### EHPS pilot operated steering valves

For larger vehicles typically big tractors, heavy fork lift trucks, loaders and dumpers, Danfoss also offers a hydraulic and electro-hydraulic pilot operated steering valve type EHPS. EHPS systems are available in three versions.

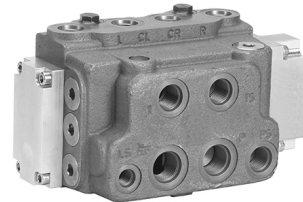

#### EHPS type 0, hydrostatic steering system

EHPS Type 0 is a purely hydraulic steering system with the EHPS valve acting as a pilot operated directional valve. A steering unit acts as a pilot unit delivering oil at a low pressure and low flow. The steering unit needs less displacement as in an ordinary hydrostatic steering system. The displacement can be optimised for emergency steering.

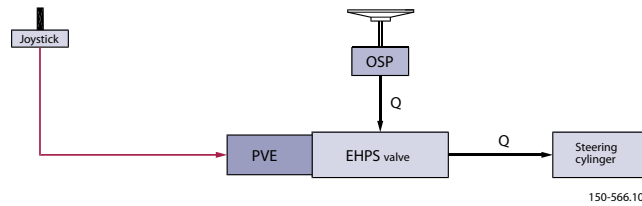

#### EHPS type 1, hydrostatic and electrohydraulic steering system

This system consists of an EHPS valve (type 0) equipped with an electrical activation unit (PVE). There are 2 possibilities of steering: either hydraulic with the steering wheel or electrical using a signal from, for example, a joystick. The valve gives highest priority to the signal from the steering wheel.

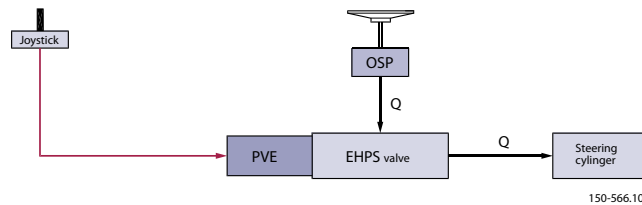

## Steering components, main data and features

### **EHPS type 2, hydrostatic and electrohydraulic steering system**

This system consists of an EHPS valve equipped with an electrical activation unit (PVED), steering wheel sensor and position sensor. Then it is possible to steer by wire with active hydraulic back up. The safety system in the integrated microcontroller gives steering with an electrical signal a very high level of safety. The characteristics are variable steering ratio on the steering wheel, elimination of steering wheel drift and the possibility of communicating with automatic steering.

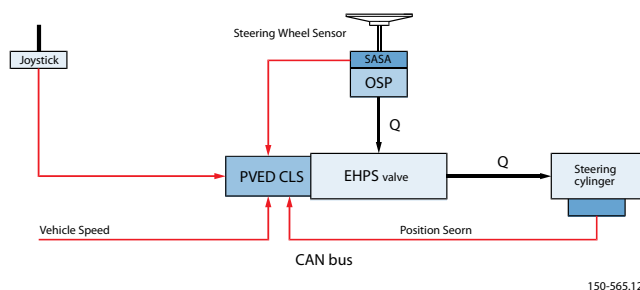

#### **Main data of EHPS:**

- Flow for steering: up to 100 l/min [26.4 US gal/min]
- Maximum steering pressure: 250 bar [3625psi]
- Maximum pump flow to priority valve in EHPS: 150 l/min [31.6 US gal/min]

#### **Features of EHPS:**

- High steering pressure requiring smaller steering cylinders.
- Low pilot pressure up to 30 bar [435 psi] for the pilot steering function giving an extremely low noise level in the cab.
- With integrated valve functions: pilot pressure relief, priority, shock and suction in L + R and pilot pressure control.
- Possibility of emergency steering (manual) in the event of pump failure.
- Minimal side acceleration on vehicles with articulated steering.
- Micro controller with safety critical software means:
  - No steering wheel drift.
  - Possibility of variable steering ratio.
  - Possibility of automatic steering
  - CAN-bus interface.
- EHPS can be built together with Danfoss proportional valves (PVG 32).

### **Pilot steering Unit OSPCX CN for EHPS**

The EHPS pilot operated steering valve requires a special pilot steering unit, viz:

- OSPCX CN

that is a closed-center steering unit whose L- and R-connections are open to tank in neutral position.

#### **Main data of the OSPC CN steering units:**

Displacement: 50-200 cm<sup>3</sup>/rev [3.05 - 12.20 in<sup>3</sup>]

## Steering components, main data and features

Maximum pilot steering pressure: 30 bar [435 psi]

### OSPE steering valve

The OSPE Load Sensing Steering Valve is available in 4 version:

- Load Sensing non-reaction (LS) dynamic
- Load Sensing Reaction (LSRM) dynamic
- "D" Load Sensing non-reaction (D-LS) dynamic with double gear set
- "D" Load Sensing Reaction (D-LSRM) dynamic with double gear set



### Main data of OSPE

- Displacement: 100-500 cm<sup>3</sup>/rev [6.10 - 30.51 in<sup>3</sup>]
- Flow, steering wheel steering: 10-50 l/min [2.64-13.21 US gal/min]
- Flow, EH Steering: 12-40 l/min [3.17-10.57 US gal/min]
- Maximum flow to priority valve in OSPE: 90 l/min [23.78 US gal/min]
- Maximum steering pressure: 210 bar [3045 psi]
- Maximum back pressure: 25 bar [363 psi]

### Features of OSPE

- Integrated EH valve in hydraulic steering unit
- True "safe-state": Shut-off valve for EH part
- Selectable "reaction" - Non-reaction" steering modes
- Integrated priority valve

### OVPL and OVR valve blocks

For the OSPL Load Sensing unit Danfoss offers a flange on valve block: OVPL

### Main data of OVPL

- Flow: 100 l/min [26.4 US gal/min]
- Max. pressure setting: 270 bar [3916 psi] on shock valves



## Steering components, main data and features

### Features of OVPL valve block

- Double service ports (2x L and 2x R) as option
- Possibility of built in valve functions: shock and suction in L + R, non-return in pump line, back pressure in tank line.

The OVR is designed specially for applications where pipes and/or hoses must run parallel with the steering column axis of the steering unit, and where space is limited.

The OVR contains no valve functions.

The OVPL and OVR can only be used in connection with steering units without spot facing around the port connections on the port surface.



F300 626

## Hydrostatic steering systems

### Open center steering system

In Open center systems a fixed displacement pump constantly supplies oil to the steering circuit separately.

#### Features of open center steering systems with Danfoss open center steering units

- Immediate reaction of the steered wheels, once the steering wheel begins to turn.
- High steering comfort maintained throughout significant changes of steering load and pump oil flow.
- Damping characteristics when system-conditioned pressure variations occur.
- Simple system build-up with stable steering under all conditions.

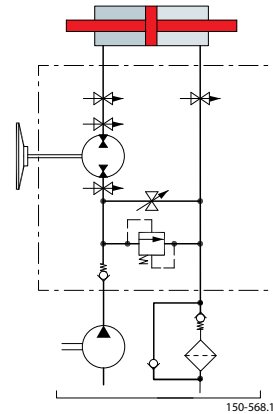

### Load sensing steering systems

In Load Sensing steering systems the oil for the steering system is supplied by a pump via a priority valve or from a pump with variable displacement.

For Load Sensing systems Danfoss offers 3 basic types of steering units:

#### Features of load sensing static steering systems with Danfoss LS static steering units

##### OSP LS Static

- No flow through the steering unit when not steering: minimum loss of energy.

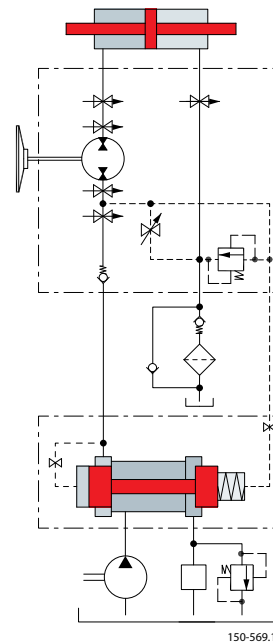



## Hydrostatic steering systems

### Features of load sensing dynamic steering systems with Danfoss LS dynamic steering units

#### OSP LS Dynamic

- Constant flow through the unit when not steering, recommended level:
- 0.6 – 0.9 l/min [0.16 – 0.24 US gal/min] for standard (low) dynamic LS steering units
- 1.0 – 1.3 l/min [0.26 – 0.34 US gal/min] for high dynamic LS steering units, to be used when extreme response is requested
- Dynamic flow causes quick reaction time when starting to steer (no hard spot)
- Check valve in P-line and in LS-line of steering unit avoids kick back at the steering wheel
- Steering unit always has the same temperature as the oil in the entire system, therefore no risk of sticking spool/sleeve set in housing even when starting up under very cold conditions

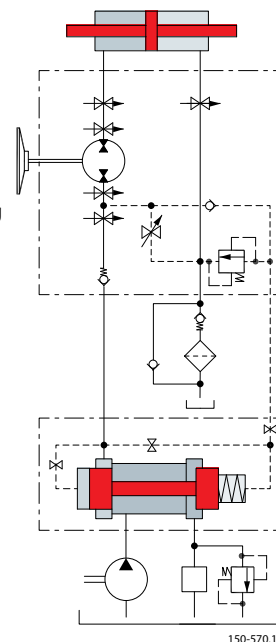

### Features of load sensing dynamic steering systems with Danfoss OSPF LS steering units

#### OSPF LS Dynamic

- Constant flow through the unit when not steering, recommended level: 1.1 - 1.5 l/min [0.29 - 0.40 US gal/min]
- Dynamic flow eliminates hard point when starting steering
- No kick back in steer wheel because of check valve in P- and no connection P-line to LS-line
- Steering unit always has the same temperature as the oil.
- OSPF is extremely good in controlling negative steering forces
- Higher max. steering speed, limited only by the capacity of the pump and the pressure setting

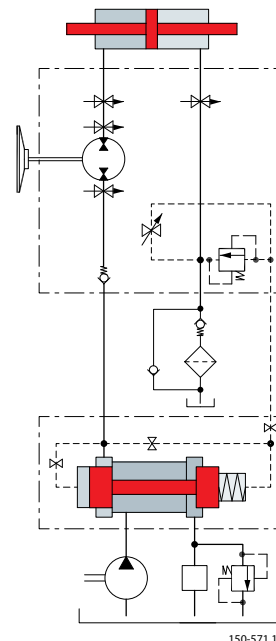

## Choice of steering concept and components

### Choice of steering concept and components

The choice of steering concept is determined mainly by vehicle design, performance requirements and required operating functions.

When a hydrostatic system is chosen, the next step involves deciding whether the hydraulic steering system is to be:

- Open Center steering system
- Power Beyond steering system
- Closed Center non-Load-Sensing steering system
- Load Sensing steering system

The choice will also depend on system cost requirements, hydraulic system energy consumption and system complexity.

When a Load Sensing system has been chosen, there are three further possibilities:

- Load Sensing Static steering system
- Load Sensing Dynamic Steering system
- Load Sensing Dynamic steering system based on Danfoss OSPF steering units

The choice here will depend on performance requirements and running-in complexity:

- Load Sensing Static steering systems are the simplest Loading Sensing types as regards the initial setting up of the priority valve spring/orifices combination. Do not recommend Static steering systems, only use if customer insists. With "Static" you risk thermal shock, which may harm the steering unit, kick back and/or hard spot in steering wheel.
- Load Sensing Dynamic steering systems give better steering performance than Static steering systems. See [Features of load sensing dynamic steering systems with LS dynamic steering units](#)
- Load Sensing Dynamic steering systems with OSPF steering units give by far the best steering characteristics. See [Features of load sensing dynamic steering systems with OSPF LS steering units](#). Such a system can require highly precise setting up of the priority valve spring/orifices combination and it is essential to ensure high "dynamic" flow from the priority valve, min. 1.1 l/min [0.29 US gal/min].

When specifying a steering system, there are two steering unit options, viz. "Reaction" and "Non-reaction":

- With reaction steering units, any external forces that act on the steered wheels result in a corresponding movement of the steering wheel, when the driver is not steering the vehicle
- With non-reaction steering units there is no such corresponding movement of the steering wheel, when the driver is not steering the vehicle

For vehicles with rear-wheel steering and articulated steering, or for vehicles that require a steering unit displacement  $>250 \text{ cm}^3/\text{rev}$  [ $15.25 \text{ in}^3/\text{rev}$ ], Danfoss always recommends non-reaction steering units.

Size calculations on steering cylinders, steering units and pumps for steering systems are given in "General information" in the next section.

If a suitable compromise cannot be achieved between minimum necessary displacement determined by maximum desired number of steering wheel revolutions from lock to lock, and maximum permissible displacement for building up the steering pressure in emergency situations with pump failure, it is possible to choose a steering unit with variable displacement: type OSPD or OSPU.

### Legislation of steering systems

Please pay attention to country specific legislation for hydraulic/electro-hydraulic steering systems in public traffic. The most wellknown of these in Europe are the EU directive 2009/66/EC and the ISO 5010 standard.

## General Information

### Technical data common

Ambient temperature		min.	-30°C	[-22°F]
		max.	+60°C	[140°F]
Surface treatment	Permissible temperature assuming non-activated steering unit	120°C [248°F] for 20 minutes		
Oil temperature		min.	-30°C	[-22°F]
		max.	90°C	[194°F]
Recommended oil temperature		min.	30°C	[86°F]
		max.	60°C	[140°F]
Oil viscosity		min.	10 mm <sup>2</sup> /s	[59 SUS]
		max.	1000 mm <sup>2</sup> /s	[4629 SUS]
Recommended viscosity		min.	12 mm <sup>2</sup> /s	[66 SUS]
		max.	80 mm <sup>2</sup> /s	[370 SUS]
Filtration	Max. degree of contamination ISO 4406	ON/OR	22 / 20 / 17	
		LS/CN/PB	21 / 19 / 16	
Temperature-difference between steering unit and other hydraulics		max.	Δ10°C	[Δ18°F]
Steering torque, OSPM	Normal steering		0.5 - 1.5 N•m	[4.43 - 13.3 lbf•in]
	Manual steering <sup>1)</sup>		Max. 80 N•m	[708 lbf•in]
	Momentary load		Max. 160 N•m	[1416 lbf•in]
Steering torque, other OSP	Normal steering, OSPF		0.5 - 1.8 N•m	[4.43-15.93 lbf•in]
	Normal steering, OSPL		1.5 - 4.0 N•m	[13.3 - 35.4 lbf•in]
	Normal steering other OSP		0.8 - 3.0 N•m	[7.08 - 26.55 lbf•in]
	Manual steering <sup>1)</sup>		Max. 120 N•m	[1062 lbf•in]
	Momentary load		Max. 240 N•m	[2124 lbf•in]

<sup>1)</sup> Steering units must not be used for continuous manual steering, max.1% of life cycle

### Manual steering pressure

Under normal operating where the steering pump supplies an adequate oil flow at the required pressure, the maximum torque on the steering wheel will not exceed 5 N•m [44.2 lbf•in]. If the oil flow from the steering system pump fails or is too small, the steering unit functions automatically as a manual steering pump.

Manual steering can only be used for a limited control of the vehicle if a sudden drop of pump pressure or flow occurs.

The table below shows the nominal manual steering pressure ( $P_m$ ) for all sizes of Danfoss steering units type OSPM at a steering wheel torque of 80 N•m [708 lbf•in].

The values apply only if the suction conditions on the steering unit T port are adequate.

OSPM		32	50	63	80	100
$P_m$	bar	125	80	65	50	40
	[psi]	[1813]	[1160]	[945]	[725]	[580]

The table below shows the nominal manual steering pressure ( $P_m$ ) for all types of Danfoss steering units except OSPM at a steering wheel torque of 120 N•m [1062 lbf•in] a value which is considered to be the

**General Information**

maximum torque an average size operator can exert. The values apply only if the suction conditions on the steering unit T port are adequate.

OSP		50	60	70	80	100	125	160	200	315	400	500	630	800	1000
P <sub>m</sub>	bar	120	100	85	75	60	50	40	30	20	15	12	10	8	6
	[psi]	[1740]	[1450]	[1235]	[1090]	[870]	[725]	[580]	[435]	[290]	[217]	[174]	[145]	[116]	[87]

**Demands on steering columns**

To ensure proper steering performance, the following demands must be fulfilled:

- the steering column must not generate any axial or radial forces on the input shaft of the steering unit
- the steering column must only be provided with one bearing (in the top)
- the welded journal must be coaxial with the spigot hole of the column

Below are stated dimensions for the steering column spline shaft and foot plate to be fulfilled.

Data's for steering columns for OSPB, OSPC, OSPD, OSPE, OSPF, OSPL and OSPU steering units:

Involute spline data for steering column Involute spline data acc. to ANSI B92.1		
Teeth	12	
Pitch angle	30°	
Diametral pitch/stub pitch	16/32	
Pitch Diameter	∅19.05 [0.75]	
Outer diameter	∅20.3±0.1 [0.80±0.01]	
Smallest diameter	∅16.5 +0.5 [0.65 +0.02]	
Min. diameter over two pins	∅23.47 -0.1 [0.92 - 0.01]	
Pin diameter	∅3.048±0.001 [0.12±0.001]	<p>*T=thickness of console plate.</p> <p>When column is mounted directly on steering unit, S=6.5 mm [0.26 in]</p>

**General Information**

Data's for steering columns for OSPM steering units:

Involute spline data for steering column Involute spline data acc. to DIN5482 A17x14	
Teeth	9
Outer diameter	∅20 -0+0.11 [0.79 -0+0.04]
Smallest diameter	∅14 -0+0.11 [0.55 -0+0.04]
Min. diameter between two pins	∅11.07 ±0.05 [0.43 ±0.01]
Pin diameter	∅3 ±0.001 [0.12 ±0.001]
Pin flat grinded against spline bottom	1.5 -0.1+0 [0.10 -0.1+0]

min.15 full spline

S=13±1-T\*  
[S=0.51±0.04-T\*]

Max 4.0 [0.16]

∅3±0.001  
[∅0.12±0.001]

1.5±0.1  
[0.10±0.01]

∅3±0.001  
[∅0.12±0.001]

2.5±0.08  
[0.10±0.01]

P301 252

\*T=thickness of console plate.

When column is mounted directly on steering unit, S=13 mm [0.51 in]

**Steering components, main data and features**

In EU directive 2009/66/EC specifies the maximum permissible steering-wheel rim force in an emergency steering situation (Please consult the directives for the ruling values).

If, for example, the permissible steering wheel rim force is  $F_e = 350\text{N}$  [78.7 lbf] and the steering wheel diameter SWd is  $0.381\text{ m}$  [15"], the steering torque  $T_{SW}$  will be =

$$T_{SW} = F_e \cdot (SWd/2) = 350 \cdot (0.381/2) = 66.7\text{ N}\cdot\text{m}$$
 [590 lbf·in]

Accordingly, the obtainable maximum steering pressure will be lower than stated in the table in [Technical data common](#) on page 35.

With, for example, an OSPC 80, the maximum steering pressure Pmr, will be =

$$Pmr = Pm \text{ table} \times T_{sw}/T_{table} = 75 \times 66/120 = 41\text{ bar}$$
 [598 psi].

**Calculation of steering systems**

**Ackermann steering**

Symbols:

$M_L$  (N·m) [lbf·in]: steering torque

F (N) [lbf]: steering force

$G_S$  (N) [lbf]: force on shaft (weight)

e (mm) [in]: king pin off-set

B (mm) [in]: tyre breadth

**General Information**

$\mu_s$ : friction coefficient

S (cm) [in]: piston stroke:

r (m) [ft]: minimum effective radius arm for steering cylinders

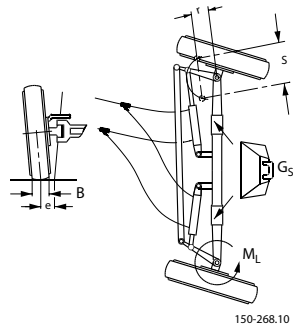

The force on the shaft is 80.000 N (8.000kg) [17.984 lbf] King pin off-set is 100 mm. [3.94 in]. Tyre breadth is 200 mm [7.87 in]

Friction coefficient between road and tyres is 0.7. Minimum effective radius arm for steering cylinders is 0.1 m [3.94 in].

According to Taborek's formula the total steering torque becomes

$$M_L = 0.05 \cdot G_s \cdot \frac{1}{1 + \frac{B}{e}} \cdot \frac{B}{200} \cdot \frac{\mu_s}{0.7}$$

$$M_L = 0.05 \cdot 80.000 \cdot \frac{1}{1 + \frac{100}{200}} \cdot \frac{200}{200} \cdot \frac{0.7}{0.7} \text{ Nm}$$

$$M_L = 2667 \text{ Nm [23606 lbf}\cdot\text{in]}$$

Cylinder piston rods must then produce a steering force of:

$$F = (M_L/r) = (2667/0.1) \text{ N} = 26.670 \text{ N [5995 lbf]}$$

**Cylinder**

*Symbols:*

F (N) [lbf]: steering force

P (bar) [psi]: steering pressure

D (cm) [in]: internal diameter of cylinder

d (cm) [in]: piston rod diameter

S (cm) [in]: piston stroke

V (cm<sup>3</sup>) [in<sup>3</sup>]: stroke volume

## General Information

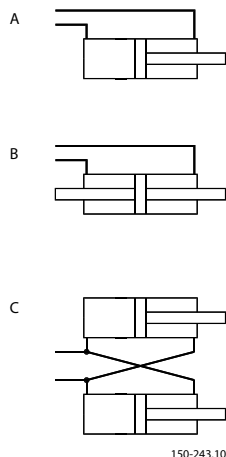

When using only one differential cylinder, the number of steering wheel revolutions from lock to lock will be different for each direction of rotation.

Use a piston seal in the cylinder to avoid leakage from one side of the piston to the other.

### A: Differential cylinder

When max. steering pressure P is led to the largest area, the steering force becomes:

$$F = P \cdot (\pi/4) \cdot D^2 \cdot 10$$

At steering to the largest area, the stroke volume becomes:

$$V = (\pi/4) \cdot D^2 \cdot S$$

With max. steering pressure P acting on the smallest area, the steering force becomes:

$$F = P \cdot (\pi/4) \cdot (D^2 - d^2) \cdot 10$$

At steering to the smallest area, the stroke volume becomes:

$$V = (\pi/4) \cdot (D^2 - d^2) \cdot S$$

### B: Balanced cylinder

$$F = P \cdot (\pi/4) \cdot (D^2 - d^2) \cdot 10$$

$$V = (\pi/4) \cdot (D^2 - d^2) \cdot S$$

### C: Cross-connected cylinders

$$F = P \cdot (\pi/4) \cdot (2D^2 - d^2) \cdot 10$$

$$V = (\pi/4) \cdot (2D^2 - d^2) \cdot S$$

### Calculation example of steering cylinder

Cross-connected cylinders are used. The steering force is 30.500 N [6857 lbf]

The steering pressure is 90 bar [1305 psi]. Piston stroke is 20 cm [7.90 in].

The relation between the piston rod diameter and internal diameter of the cylinder is  $(d/D) = (1/2)$  for the cylinder chosen.

Inserted in the formula for steering force  $30.500 = 90 \cdot (\pi/4) (2(2d)^2 - d^2) \cdot 10$

the result is  $d = 2.5$  cm [1 in] and  $D = 2 \cdot d = 5.0$  cm [2 in].

Stroke volume:  $V = (\pi/4) \cdot (2 \cdot 5.0^2 - 2.5^2) \cdot 20 = 687$  cm<sup>3</sup> [41.9 in<sup>3</sup>]

## General Information

A theoretical calculation of steering cylinders and steering pressure may result in inadequate steering forces in many dynamic steering situations in practise.

An empirical rule verifies that adding an approx. 50 bar [725 psi] pressure to the theoretically required pressure usually always ensures a satisfactory steering performance.

Based on this empirical rule, the required size of cylinder can be calculated on basis of a steering pressure that is 50 bar [725 psi] lower than the available system pressure.

Therefore, in the example illustrated above, the steering system must be able to work with a pump pressure of

$$90 \text{ bar [1305 psi]} + 50 \text{ bar [725 psi]} = 140 \text{ bar [2030 psi]}$$

### Calculation example of steering unit

*Symbols:*

$V \text{ cm}^3 [\text{in}^3]$ : stroke volume

$V_v \text{ cm}^3/\text{rev} [\text{in}^3/\text{rev}]$ : steering unit displacement

$i$  (rev): required number of steering wheel revolutions from lock to lock

The required steering unit displacement is calculated from  $V_v = (V/i)$

With a stroke volume of  $687 \text{ cm}^3 [41.9 \text{ in}^3]$  and a required number of steering wheel revolutions from lock to lock of 3 to 4, the steering unit displacement will be between 172 and  $229 \text{ cm}^3/\text{rev} [10.56 \text{ and } 13.97 \text{ in}^3/\text{rev}]$ . A steering unit with a displacement of

$200 \text{ cm}^3/\text{rev} [12.20 \text{ in}^3/\text{rev}]$  will give 3.4 steering wheel revolutions.

### Calculation example of pump

*Symbols:*

$V_v (\text{cm}^3/\text{rev}) [\text{in}^3/\text{rev}]$ : steering unit displacement

$n (\text{min}^{-1}) [\text{rev}/\text{min}]$ : required steering wheel speed

$Q (\text{l}/\text{min}) [\text{US gal}/\text{min}]$ : oil flow

The oil flow is calculated from

$$Q = V_v \cdot n \cdot 10^{-3}$$

With a displacement of  $200 \text{ cm}^3/\text{rev} [12.20 \text{ in}^3/\text{rev}]$  and a required steering speed of  $100 \text{ min}^{-1} [\text{rev}/\text{min}]$ , the oil flow will be

$$Q = 200 \cdot 100 \cdot 10^{-3} = 20 \text{ l}/\text{min}. [5.28 \text{ US gal}/\text{min}]$$

### Steering wheel revolutions and steering speed

#### **Recommended:**

Number of steering wheel revolutions from lock to lock: 3 to 5.

Steering wheel speed:  $100 \text{ to } 150 \text{ min}^{-1}/\text{min} [\text{rev}/\text{min}]$

Steering wheel speed with engine at idle:  $\text{min. } 60 \text{ min}^{-1}/\text{min}. [\text{rev}/\text{min}]$

### Calculation of LS steering system with working hydraulics

*Symbols:*

$Q (\text{l}/\text{min}) [\text{US gal}/\text{min}]$ : required oil flow for the steering system

$Q_A (\text{l}/\text{min}) [\text{US gal}/\text{min}]$ : required oil flow for the remainder of the hydraulic system



## General Information

$Q_p$  (l/min) [US gal/min]: required pump flow

The priority valve ensures priority to the steering system under any situations. In some cases the steering system can take all the oil flow from the pump.

When it is designed that the steering system and the working hydraulics do not require oil simultaneously, the necessary oil flow from the pump  $Q_p$  will equal the higher of the two oil flows ( $Q_A$  or  $Q$ ).

When working hydraulics and steering system must have oil at the same time, the necessary oil flow from the pump  $Q_P$  will equal the sum of the two oil flows ( $Q_A + Q$ ).

The necessary oil flow to the steering unit is 20 l/min [5.28 US gal/min]. Required for the working hydraulics 40 l/min [10.56 US gal/min].

If it is acceptable that the working hydraulics drop in speed during steering then the necessary oil flow from the pump will be:  $Q_p = Q_A = 40$  l/min [10.56 US gal/min].

### Calculation of steering system with flow-amplifier OSQA/OSQB

*Symbols*

$V$  (cm<sup>3</sup>) [in<sup>3</sup>]: stroke volume

$i$  (min<sup>-1</sup>) [rev]: required number of steering wheel revolutions from lock to lock

$V_v$  (cm<sup>3</sup>/rev) [in<sup>3</sup>/rev]: steering unit displacement

$f$ : amplification factor of Flow-amplifier

Steering unit displacement and amplification factor of the flow-amplifier are calculated from:

$$V_v \cdot f = (V/i)$$

### Calculation of steering system for articulated vehicle

Should you wish to size a steering system for an articulated vehicle, Danfoss will carry out computer calculations for you.

Please take a copy of the questionnaire overleaf, complete it, and send it to the Danfoss Sales organization.

**General Information**

**Articulated vehicle**

	<b>Manufacturer: Vehicle:</b>	<b>Completed by: Type:</b>	<b>Date: Project:</b>	
	<b>Units used: fill in with X:</b>		<b>metric</b>	<b>[US]</b>
	Weight of fully loaded vehicle: G max.=		kg	[lbf]
	Max. speed of vehicle:		km/h	[mph]
	Required number of steering wheel revolutions: i =		min <sup>-1</sup>	[rev]
	Steering system pump:	Type:		
	Max. steering pressure:		bar	[psi]
	Displacement:		cm <sup>3</sup>	[in <sup>3</sup> ]
	Minimum speed:		min <sup>-1</sup>	[rev/ min]
	Maximum speed:		min <sup>-1</sup>	[rev/ min]
	Loader Bucket width: W=		mm	[in]
	Other machines			
	Number of front axles:			
	Number of rear axles:			

**Complete form**

A1 =	mm	[in]	Notes:
A2 =	mm	[in]	
B1 =	mm	[in]	
B2 =	mm	[in]	
D =	mm	[in]	
d =	mm	[in]	
± α max. =	°	°	
E =			

2 cylinders E = 1 1 cylinder, left E = 2 1 cylinder, right E = 3

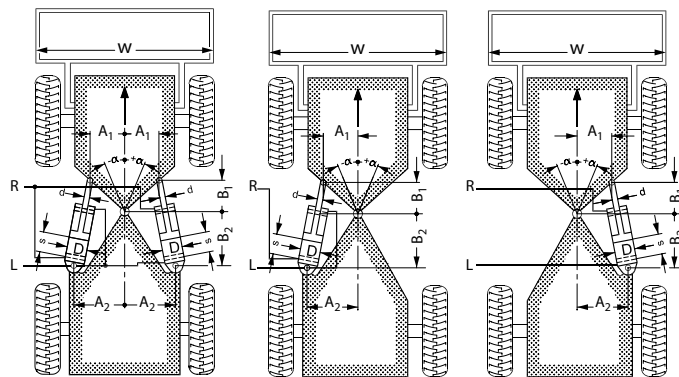

150-317.10

## General Information

### Pump for flow-amplifiers OSQA/OSQB

#### Symbols

Q (l/min) [US gal/min]:	oil flow required for steering components
Q <sub>A</sub> (l/min) [US gal/min]:	oil flow required for working hydraulics
Q <sub>p</sub> (l/min) [US gal/min]:	oil flow required from pump
V <sub>v</sub> (cm <sup>3</sup> ) [in <sup>3</sup> ):	steering unit displacement
f:	amplification factor of flow-amplifier
n (min <sup>-1</sup> ) [rev/min]:	required steering speed

The integral priority valve in the flow-amplifier ensures priority to the steering system. When it is designed that the steering system and the working hydraulics do not operate simultaneously, the oil flow required from the pump Q<sub>p</sub> will equal the higher of the two oil flows (Q<sub>A</sub> or Q).

$$Q = V_v \cdot f \cdot n \cdot 10^{-3}$$

When working hydraulics and steering system must have oil at the same time, the oil flow required from the pump Q<sub>p</sub> will equal the total of the two oil flows (Q<sub>A</sub> + Q).

## Oil types

### Mineral oils

When using mineral based hydraulic oil, we recommend the addition of a sufficient quantity of antiwear additive of a type that is active under boundary lubrication conditions at low temperatures.

Mineral oils are normally suitable if they belong to one of the three following groups:

- HM oil, possibly HV (ISO 6743/4, CETOP RP 91H) or H-LP oil (DIN 51524)
- Automatic Transmission Fluids (ATF A)
- SE- and CD motor oil (American Petroleum Institute (API))

The large content of additives in motor oils may produce sediment that can block valves and filters. If there is doubt about the suitability of an oil, please contact Danfoss Sales Organisation.

### Non-flammable or biodegradable hydraulic fluids

To an increasing extent Danfoss steering components are being used in systems with non-flammable hydraulic fluids.

These fluids normally belong to one of the following groups according to ISO 12922:

Oil in water emulsion: HFA

Water in oil emulsion: HFB

Water/polymer solution: HFC

Waterfree synthetic fluids: HFD-U

Please contact the Danfoss Sales Organisation regarding the use of non-flammable or biodegradable fluids

### Sealing materials

The seals in steering components are of nitrile rubber NBR (Buna N) and teflon PTFE.

If synthetic fluid is to be used in the steering system, please contact the Danfoss Sales Organization regarding sealing material.

## General Information

### Oil temperature

Oil life will be drastically reduced because of oxidizing if the operating temperature exceeds 60 °C [140°F] for long periods.

A rule of thumb is that oil life is halved for each 8 °C [46.4°F] in excess of 80 °C [176°F].

Impurities in the oil, e.g. particles or water, will further reduce its life.

## Particle content, degree of contamination and filtering

### Particle content, degree of contamination

The oil must be filtered to prevent the particle content from exceeding an acceptable level, corresponding to an acceptable degree of contamination. The maximum ISO degree of contamination (see ISO 4406 or CETOP RP 70) is

- for load sensing, closed center steering components and power beyond steering units: 21/19/16
- for open center steering components: 22/20/17

### Filtering

How fine the filtering must be and where the filters are to be placed is always a compromise.

In systems with a good air filter and effective dust sealing, and which operate in clean

surroundings, the degree of contamination can normally be kept within the limits laid down by using a return filter of 25 µm nominal (40-50 µm absolute) or finer.

Conversely, systems operating with a poor air filter and inadequate dust sealing - in dusty surroundings - will often require more than one filter of 10 µm absolute. The filters can be pressure or return filters.

## Installation

- Never paint steering unit on steering column surface to avoid misalignment between steering unit and column.
- Install the steering column so that it cannot generate any axial or radial forces on the input shaft of the steering unit.
- All hydraulic components should be placed so that they are easily accessible.
- All hydraulic components should be installed outside the cabin of the vehicle.
- There should be manometer connections in pump and tank lines.
- Install the cylinders with the ports facing upwards to avoid air pockets.
- Mounting surfaces should be flat in order to ensure effective contact.
- Hydraulic pilot lines must be fitted in such a way that air pockets are avoided.
- Install the hydraulic components as stated in their individual installation instructions.
- Installation instructions are enclosed inside the packaging or can be ordered from Danfoss Power Solutions, sales organization.
- The hydraulic components must not be forced or twisted into alignment by the fixing screws.
- Packing yarn, teflon, and other unsuitable sealing material must not be used on port adaptors. Use bonded seals, O-rings, steel washers, and similar materials.
- Do not remove the plastic plugs until pipes and hoses are to be fitted.
- When removing the plastic plugs, make sure that no paint flags or other dirt particles are entering the ports of the hydraulic components.

## General Information

- Never tighten the screwed connections with a torque higher than the max. tightening torques stated in the instructions.
- The oil must have a contamination level better than the ISO 4406 code stated in [Technical data common](#) on page 35
- Always refill the system through a filter.

## Tightening torques

Connections	Recommended tightening torque N·m [lbf·in]			
	With cutting edge	With copper washer	With alum. washer	O-ring
G 1/4	35 [309]	35 [309]	35 [309]	-
G 3/8	70 [619]	45 [398]	50 [442]	-
G 1/2	100 [885]	55 [486]	80 [708]	-
G 3/4	180 [1593]	90 [796]	130 [1150]	-
7/16-20 UNF	-	-	-	20 [177]
3/4-16 UNF	-	-	-	60 [531]
7/8-14 UNF	-	-	-	90 [796]
1 1/16-12 UN	-	-	-	120 [1062]
M12 • 1.5	30 [265]	20 [177]	30 [265]	25 [221]
M18 • 1.5	80 [708]	55 [486]	70 [619]	50 [442]
M22 • 1.5	100 [885]	65 [575]	80 [708]	60 [531]
9/16 - 18 UNF, ORFS	-	-	-	25 [221]
11/16 - 16 UN, ORFS	-	-	-	27 [239]

Danfoss Steering Components can withstand the tightening torques stated. However it is recommended to use torque levels stated by supplier of fittings.

## Starting up and running in

- Start the prime mover and where possible allow it to run at the lowest speed.
- Check the direction of pump shaft rotation.
- Any bleed screws must be left open until oil emerges without foam.
- In load sensing systems ensure that all signal lines are full of oil.
- Start steering slowly from one end-lock to the other for a minimum of five cycles to bleed out all air.
- Signs of air in the hydraulic system
  - foam in the tank
  - jerky operation of actuator motor or cylinder
  - noise
- Refill again, if necessary.
- The system should not be loaded until completely bled.
- The hydraulic system is checked for tightness and satisfactory function.
- Check pressure in P and T:

### General Information

- Max pressure P-T, when steering up against end lock, must match specification.
- T- pressure absolute: T- pressure must be above atmospheric pressure in any steering situation, also when changing steering direction rapidly. In some steering system it will be necessary to have installed back pressure valve in T-line to ensure positive tank pressure in any steering situation. See [Examples of steering systems](#) on page 47 for back pressure valve installations.
- After running in: change the oil filter, if necessary.

### Maintenance

- Careful maintenance is essential to the reliability and life of the hydraulic system.
- Oil, oil filters, and air filters must be changed in accordance with the supplier's instructions.
- The condition of the oil must be checked at suitable intervals.
- System tightness and oil level must be checked frequently.

## General Information

### Information on labels

The label on all Steering components has included:

- Danfoss logo
- Type designation
- Code number
- Serial number
- Bar codes, includes information of code number and serial number

The serial number has 8 characters stating this information given by an example:

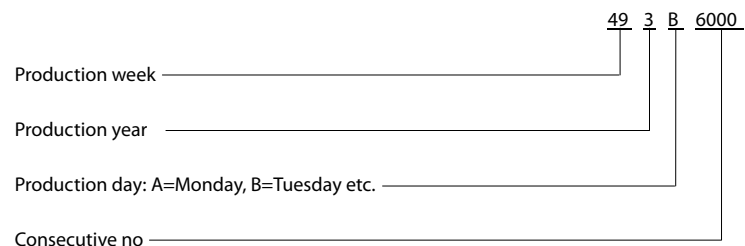

### Examples of steering systems

#### OSPC ON

OSPC ON steering units contain one or more of the following possible valve functions:

- pressure relief valve
- shock valves
- suction valves
- check valve

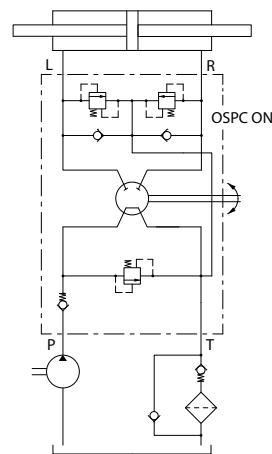

150-367.11

**General Information**

**OSPC OR**

OSPC OR steering units contain one or more of the following possible valve functions:

- pressure relief valve
- suction valves
- check valve
- shock valves if needed

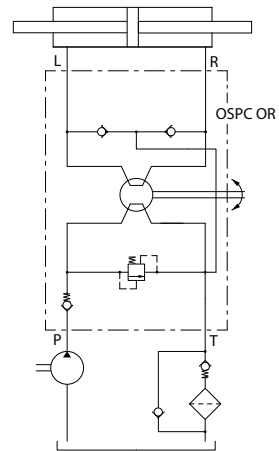

150-429.11

**OSPC LS + OLSA**

Steering unit with flange mounted priority valve OLSA and steering column with sensor.

When the driver turns the steering wheel, the steering wheel sensor sends a signal to the relay box activating the electric motor that drives the hydraulic system pump. The system must also include a signal source in the working hydraulics.

A PVRES control lever for example.

The system is therefore energy-optimised, so that the hydraulic pump runs only when the hydraulic functions are active.

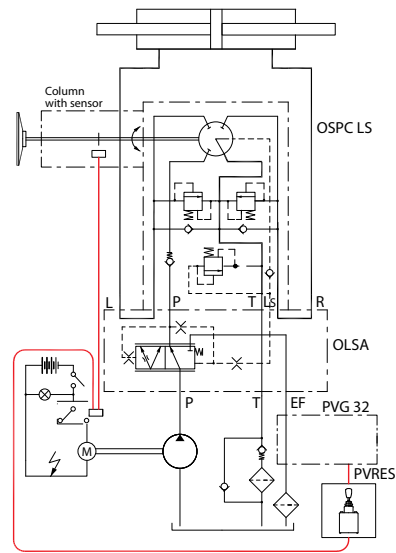

152877.11



**General Information**

**OSPF + OLS**

Load sensing steering system with variable displacement pump.  
 The pump and the working hydraulics circuit must be protected by a separate pressure relief valve.

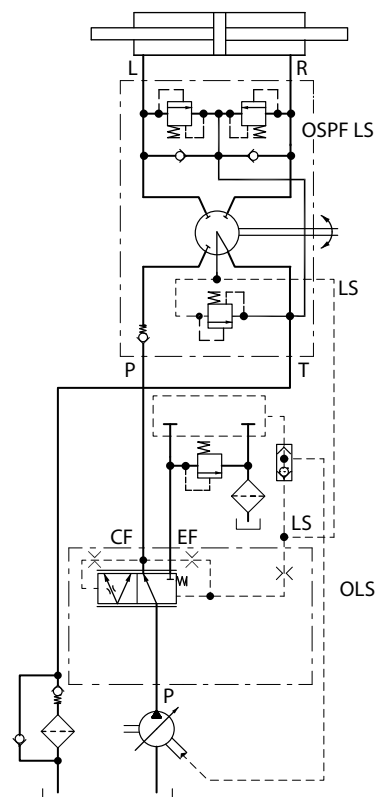

150-394.11

**OSPD LS**

Steering unit with two rotary meters.  
 With OSPD even heavy vehicles can in many cases fulfil legislations and be steered without the emergency steering pump. An OSPD makes it possible to select a ratio between normal steering displacement and emergency steering displacement up to a factor of 5. The pump and the working hydraulics circuit must be protected by a separate pressure relief valve.

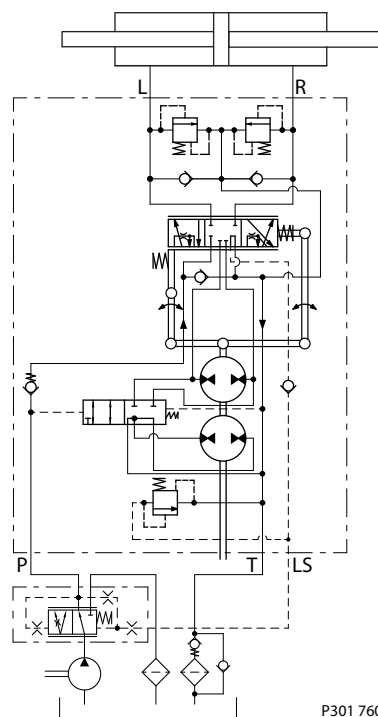

P301 760.B

**General Information**

**OSPU LS**

Steering unit with amplification.  
 With OSPU even heavy vehicles can in many cases fulfil legislations and be steered without the emergency steering pump.  
 OSPU allows the selection of an amplification factor of 2, 3 or 4.  
 In case of working hydraulic connected to EF port of priority valve, the pump and the working hydraulics circuit must be protected by a separate pressure relief valve.

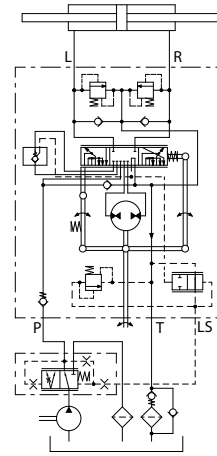

P301 761

**General Information**

**OSPBX LS and OSQA**

The pilot pressure relief valve in OSQA only protects the steering circuit. The pump and the working hydraulics circuit must be protected by a separate pressure relief valve.

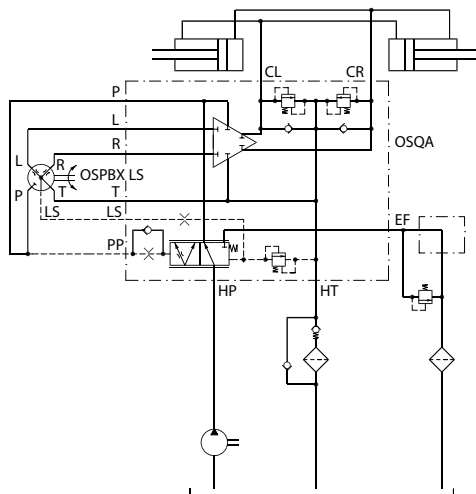

**General Information**

**2 x OSPBX LS and OSQB**

The steering components are connected by three shuttle valves. The pilot pressure relief valve in OSQB only protects the steering circuit.

The pump and the working hydraulics circuit must be protected by a separate pressure relief valve.

Steering systems with flow-amplifiers make it possible to connect working hydraulics to the EF connection. The built-in priority valve ensures first priority to the steering circuit.

When the steering wheel is turned, the priority valve ensures that the necessary oil flow is led to the steering circuit. The rest is available for the working hydraulics.

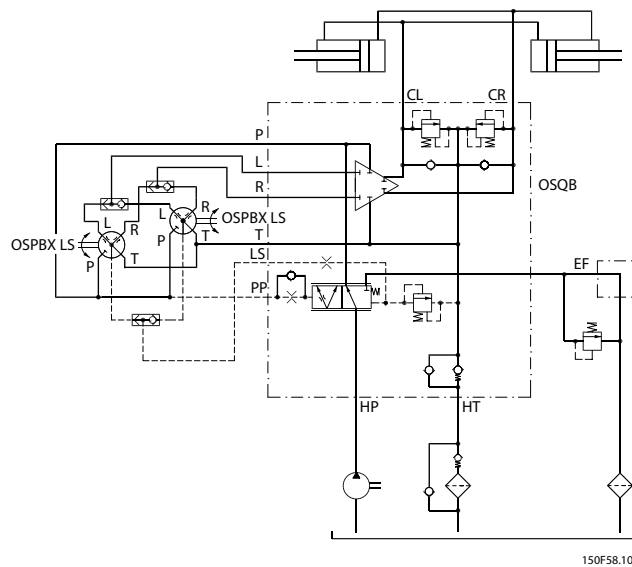

**General Information**

**OSPBX LS and OSQA shown with electrically driven pump for emergency steering.amplification during emergency steering**

The pump for emergency steering is operated when the pressure in the HP line is below the stand-by level. The pump for emergency steering supplies the HP line with oil.

So amplification is maintained during emergency steering. The pilot pressure relief valve in OSQA only protects the steering circuit.

The pumps and the working hydraulics circuit must be protected by separate pressure relief valves.

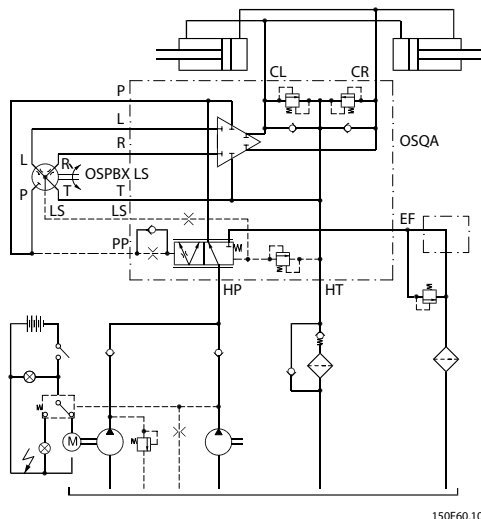

150F60.10

**General Information**

**OSPCX LS and OSQB/OLSQ with integrated priority valve for emergency circuit**

When under normal steering conditions the stand-by pressure in the main circuit (minimum 7 bar [102 psi]) priority valve spring in OSQ) overrules the spring pressure in OLSQ (4 bar [58 psi] spring), OLSQ's priority valve will pass oil from the emergency steering pump across OLSQ's P-connection to the flow amplifier's HT tank connection.

If the oil supply from the main pump (HP) should fail, the stand-by pressure of OSQ's priority valve in the main pump circuit disappears and relocates the spool in OLSQ to enable the oil from the emergency steering pump to enter the pump circuit (P) in the OSQ.

The pilot pressure relief valve in OSPCX LS only protects the steering circuit. The pumps and the working hydraulics circuit must be protected by separate pressure relief valves.

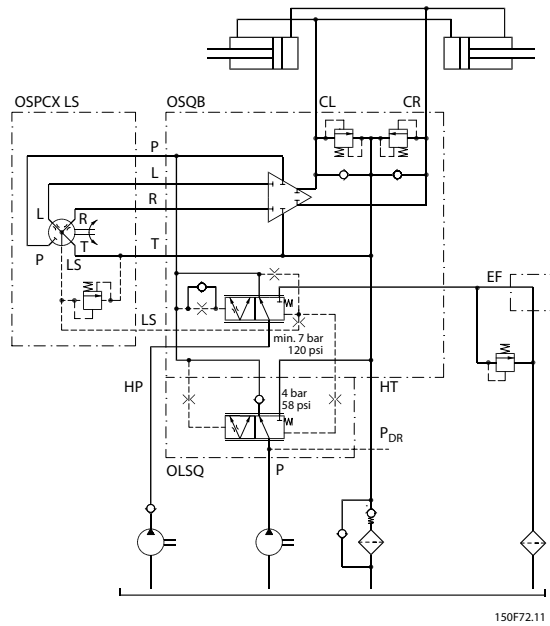

**General Information**

**EHPS - type 1 steering valve with PVG 32, OSPCX pilot steering unit and PVRES joystick**

The vehicle can be steered with either the PVRES joystick or with the OSPCX pilot steering unit. The signal from the steering unit has priority on simultaneous activation of steering wheel and joystick.

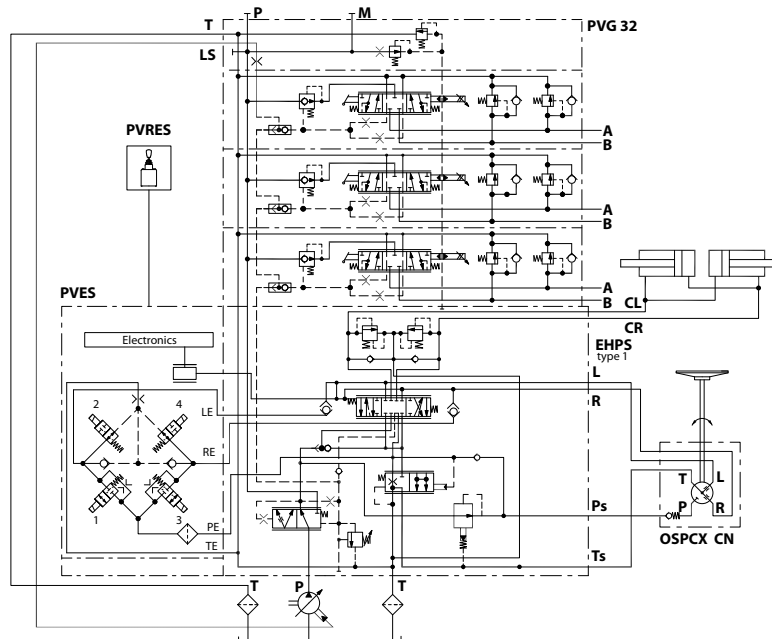

150-575.14

**General Information**

**EHPS - type 2 steering valve with control module PVED, OSPCX pilot steering unit and joystick**

The vehicle can be steered either:

- automatically with a signal from an external signal source, e.g. range sensor or a GPS signal, or
- manually with a joystick, or with an OSPCX pilot steering unit.

The signal from the steering unit has priority:

When the steering wheel is activated, the signal from the automatic steering valve discontinues and with simultaneous activation of steering wheel and joystick, the turning direction of the steered road wheels will correspond to the direction of rotation of the steering wheel.

The signal from the steering wheel sensor gives:

- variable steering wheel ratio
- Zero-slip function: the steering wheel position corresponds to the position of the steering cylinder.
- The pump and the working hydraulics circuit must be protected by a separate pressure relief valve.

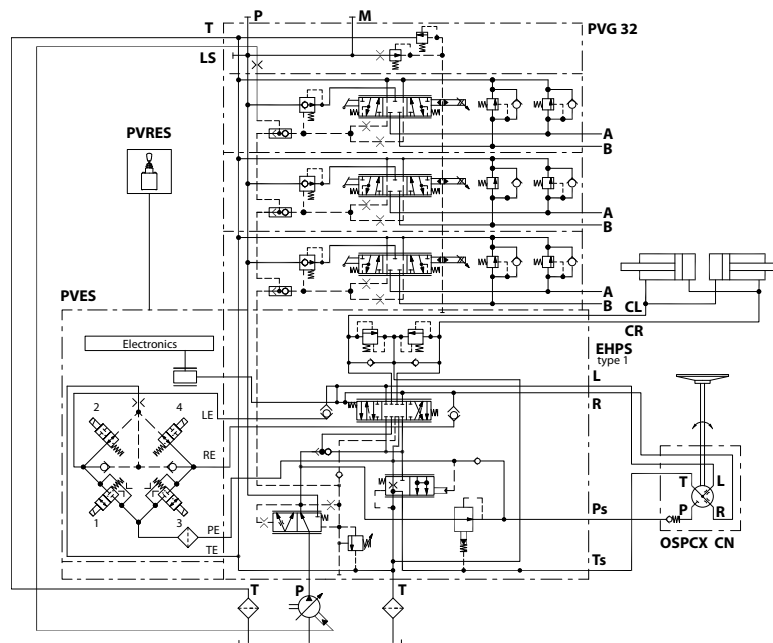

150-575.14



**General Information**

**OSPE in system with variable pump and GPS steering**

The pump must have a built in pilot pressure relief valve to protect the OSPE, the priority valve part, the working hydraulics and the AUX function. AUX can be a brake system, which must have limited oil consumption to ensure steering capability in any case.

Alternative pressure protection must be present in working and in AUX-hydraulic.

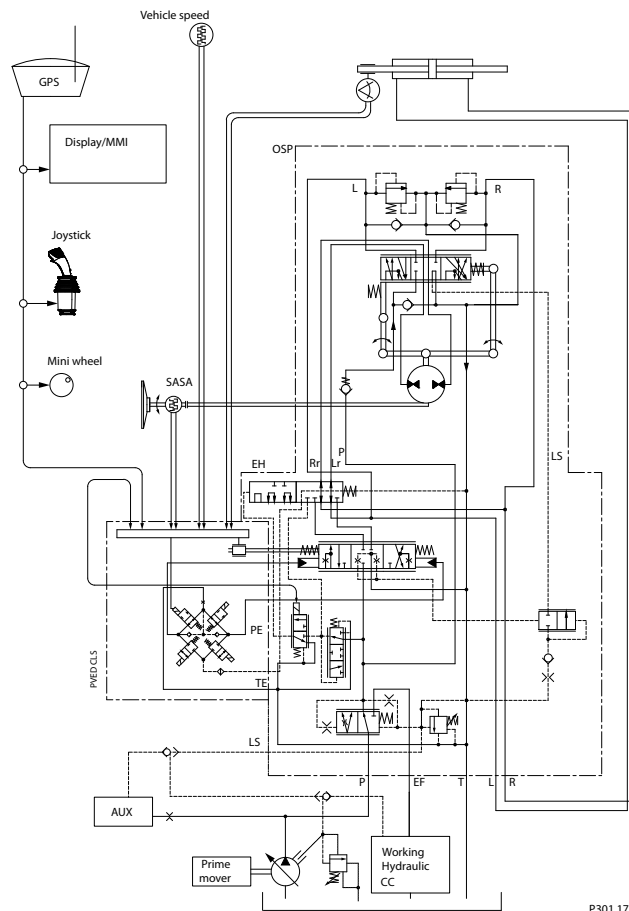

**General Information**

**Load sensing steering system and load sensing working hydraulics with common oil supply from a fixed displacement pump**

The pump oil flow is fed in from a priority valve OLS 120 or OLS 160, which ensures priority to steering.

The built-in pilot pressure relief valve in OSPC LS protects the steering circuit.

The built-in pilot pressure relief valve in Danfoss proportional valve PVG 32 protects the working hydraulics circuit.

The first working hydraulics section is shown with a Danfoss hydraulic motor .

Shock and suction valves are built into the proportional valve.

The second working hydraulics section is shown with a Danfoss hydraulic motor.

The third working hydraulics section is shown with LS pressure relief valves built into the proportional valve. Hereby maximum working pressure can be set separately for port A and port B.

Please contact the Danfoss Sales Organization regarding assembly possibilities for your application.

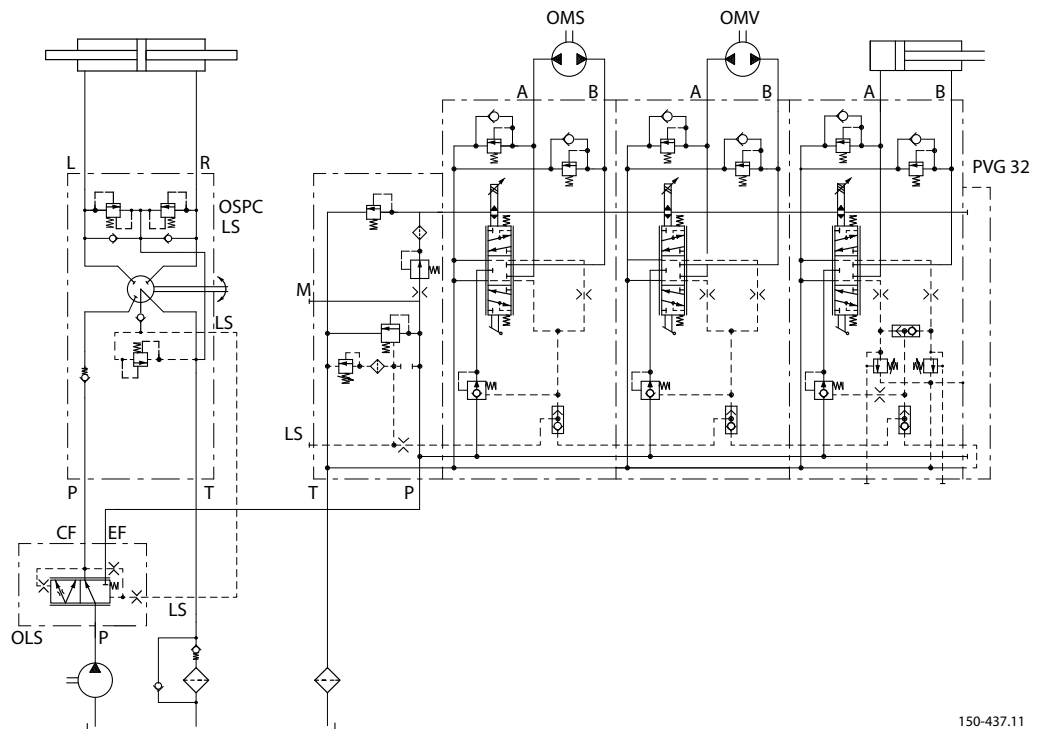

150-437.11



**Products we offer:**

- Bent Axis Motors
- Closed Circuit Axial Piston Pumps and Motors
- Displays
- Electrohydraulic Power Steering
- Electrohydraulics
- Hydraulic Power Steering
- Integrated Systems
- Joysticks and Control Handles
- Microcontrollers and Software
- Open Circuit Axial Piston Pumps
- Orbital Motors
- PLUS+1® GUIDE
- Proportional Valves
- Sensors
- Steering
- Transit Mixer Drives

**Danfoss Power Solutions** is a global manufacturer and supplier of high-quality hydraulic and electronic components. We specialize in providing state-of-the-art technology and solutions that excel in the harsh operating conditions of the mobile off-highway market. Building on our extensive applications expertise, we work closely with our customers to ensure exceptional performance for a broad range of off-highway vehicles.

We help OEMs around the world speed up system development, reduce costs and bring vehicles to market faster.

Danfoss – Your Strongest Partner in Mobile Hydraulics.

**Go to [www.powersolutions.danfoss.com](http://www.powersolutions.danfoss.com) for further product information.**

Wherever off-highway vehicles are at work, so is Danfoss. We offer expert worldwide support for our customers, ensuring the best possible solutions for outstanding performance. And with an extensive network of Global Service Partners, we also provide comprehensive global service for all of our components.

Please contact the Danfoss Power Solution representative nearest you.

**Comatrol**

[www.comatrol.com](http://www.comatrol.com)

**Turolla**

[www.turollaocg.com](http://www.turollaocg.com)

**Hydro-Gear**

[www.hydro-gear.com](http://www.hydro-gear.com)

**Daikin-Sauer-Danfoss**

[www.daikin-sauer-danfoss.com](http://www.daikin-sauer-danfoss.com)

Local address:

**Danfoss  
Power Solutions (US) Company**  
2800 East 13th Street  
Ames, IA 50010, USA  
Phone: +1 515 239 6000

**Danfoss  
Power Solutions GmbH & Co. OHG**  
Krokamp 35  
D-24539 Neumünster, Germany  
Phone: +49 4321 871 0

**Danfoss  
Power Solutions ApS**  
Nordborgvej 81  
DK-6430 Nordborg, Denmark  
Phone: +45 7488 2222

**Danfoss  
Power Solutions Trading  
(Shanghai) Co., Ltd.**  
Building #22, No. 1000 Jin Hai Rd  
Jin Qiao, Pudong New District  
Shanghai, China 201206  
Phone: +86 21 3418 5200

Danfoss can accept no responsibility for possible errors in catalogues, brochures and other printed material. Danfoss reserves the right to alter its products without notice. This also applies to products already on order provided that such alterations can be made without changes being necessary in specifications already agreed. All trademarks in this material are property of the respective companies. Danfoss and the Danfoss logotype are trademarks of Danfoss A/S. All rights reserved.