

Technical Information

Foot Pedal

# KEP Uni-directional and Bi-directional



**Revision history***Table of revisions*

<b>Date</b>	<b>Changed</b>	<b>Rev</b>
July 2015	Converted to Danfoss layout	EA
November 2011	Corrected Option 1 and 2 drawing	DA
October 2011	Added interchangeable part number reference to Unidirectional Model Type table	CB
September 2010	Major update	CA
January 2010	Major update	BA
January 2009	Initial release	AB

**Contents**
**Overview**

Description.....	4
Features.....	4
Uni-directional model type.....	4
Bi-directional model type.....	4
Operation.....	4
Uni-directional model type .....	4
Bi-directional model type.....	5
Ordering information.....	5
Uni-directional model type.....	5
Bi-directional model type.....	5
Optional connector.....	6

**Technical data**

Uni-directional model type.....	7
Bi-directional model type.....	8

**Dimensions**

Uni-directional model type.....	9
Bi-directional model type.....	10

**Output characteristics**

Uni-directional model type.....	11
Bi-directional model type.....	11

**Electrical connections**

Uni-directional model type .....	13
Bi-directional model type.....	14
Wiring harness.....	14
Connector A: Metri-Pack connector.....	15
Connector B: Weather Pack connector (shroud).....	15
Connector C: Weather Pack connector (tower).....	15
Schematics of a foot pedal connected to a PLUS+1® module.....	16
Example, part 1.....	16
Example, part 2.....	17
PLUS+1® module pin connections example.....	18

## Overview

## Description

The electronic foot pedal is used to drive vehicles equipped with hydrostatic transmissions and/or electronically-controlled engines. It provides an electrical signal to the engine's electronics proportional to the degree of pedal actuation. The electronic foot pedal features a sensor specifically designed for heavy vehicle applications.

Danfoss offers two types of foot pedals: Uni-directional and Bi-directional. The uni-directional uses a potentiometer sensor and was the first electronic foot pedal introduced by Danfoss in 1993. The new bi-directional type uses Hall effect sensors. Both types of foot pedals are PLUS+1<sup>®</sup> Compliant.

## Features

### Uni-directional model type

- Potentiometer sensor
- Meets or exceeds FMVSS-124 requirements
- Low pivot point eliminates need for external heel rest
- Controls acceleration and deceleration smoothly
- Potentiometer mounting location minimizes mounting space requirements and reduces vulnerability to dirt, water, and foreign contaminants
- 3 pin Weather Pack compatible connector

### Bi-directional model type

- Hall effect sensors
- $14 \pm 2^\circ$  angular rotation, fore and aft
- FMVSS 124 and 302 compliant
- Dual ratiometric Automatic Protection Switching (APS) output
  - This feature provides redundancy
- Independent, isolated APS circuits
- Protected against electrical misconnection
- 6 pin Metri-Pack 150 Series connector directly on the sensor
- Two 3 pin Weather Pack compatible connector
  - These connectors are used with the recommended cable (reference [Schematics of a foot pedal connected to a PLUS+1 module](#) on page 16)
- Non contact sensor
- Black coated steel base and treadle
- Chromate conversion module components

## Operation

### Uni-directional model type

The electronic foot pedal accepts a typical supply voltage of 5 Vdc and varies the output from 10% to 90% of supply through the pedal's rated angle. Three standard accelerator position sensor models are available for vehicle toeboard angles ranging from 0° to 25°. Custom mounting, termination, and electrical characteristics are available upon factory request.

## Technical Information **KEP Foot Pedal**

### Overview

#### Bi-directional model type

The electronic foot pedal contains two independent non-contact transducers (Hall elements). The transducers are designed to operate at 5 Vdc.

The signal range for each transducer can be configured to match a machine's requirements. Currently, two different signal options are offered, reference Technical data, [Bi-directional model type](#) on page 8.

### Ordering information

Use product description and part numbers for ordering electronic foot pedals. For detailed specifications, refer to chapters [Technical data](#) on page 7; [Dimensions](#) on page 9; and [Electrical connections](#) on page 13.

#### Uni-directional model type

Description		Foot pad	Mating connector	Angle	Signal 1	Signal 2	Transducer	Part number
KEPA14181	Uni-directional	Rubber	Weather Pack	28° <sup>1</sup>	10% to 90%		2500 Ohms <sup>2</sup>	KEPA14181 <sup>3</sup>
KEPA14161	Uni-directional	Rubber	Weather Pack	35° <sup>1</sup>	10% to 90%		2500 Ohms <sup>2</sup>	KEPA14161 <sup>3</sup> 791681N <sup>4</sup>
KEPA14171	Uni-directional	Rubber	Weather Pack	45° <sup>1</sup>	10% to 90%		2500 Ohms <sup>2</sup>	KEPA14171 <sup>5</sup>

<sup>1</sup> Refer to Technical data, [Uni-directional model type](#) on page 7 and [Bi-directional model type](#) on page 8.

<sup>2</sup> Plus a 1K internal current limiting resistor.

<sup>3</sup> US part number.

<sup>4</sup> EU part number.

<sup>5</sup> Interchangeable US part number is 11044101.

#### Mating electrical connector

Description	Part number
3 pin Weather Pack kit	K08620

#### Bi-directional model type

Description		Foot pad	Mating connector	Angle	Signal 1	Signal 2	Part number
Option 1	Bi-directional	Rubber	6 pin Metri-Pack 150 Series	±14°	10% to 90%	90% to 10%	11065877
Option 2	Bi-directional	Rubber	6 pin Metri-Pack 150 Series	±14°	10% to 80%	20% to 90%	11065874

#### Danfoss recommended mating electrical wire harness and connectors

Description		Part number
6 pin Metri-Pack 150 Series	100 cm (39.37 in) from end to end	11065878
Two 3 pin Weather Pack		
3 pin Weather Pack tower kit	Used with wire harness, Danfoss part number 11065878	K08620
3 pin Weather Pack shroud kit		K08630

**Overview*****Optional connector***

---

The optional mating electrical connector for the bi-directional model type must be ordered directly from a Packard Electric (Delphi Connection Systems) supplier.

---

** Caution**

---

The electrical connection may be at risk. Wiring directly to the 6 pin Metri-Pack connector, which is integral to the sensor, may not provide the flexibility and overall integrity that can otherwise be obtained by using the Danfoss recommended harness (Danfoss part number 11065878).

---

***Optional mating electrical connector piece parts for bi-directional model type***

Description		Packard Electric part number
6 pin Metri-Pack 150 Series	One Connector and Seal	12066317
	Six Terminals	12013881

---

**Technical Information    KEP Foot Pedal**

---

**Technical data**
**Uni-directional model type**
*Electrical and environmental technical data*

<b>Supply voltage</b>	Typical: 5.0 Vdc Maximum: 16 Vdc (5 minutes)
<b>Operating temperature</b>	-40 to +70° C [-40 to +158° F]
<b>Maximum rated output current</b>	20 mA
<b>Pedal potentiometer resistance</b>	2500 ± 500 Ohms, plus a 1K internal current limiting resistor
<b>Sealing of electronics</b>	IP 66

*Materials*

<b>Castings</b>	Iridited aluminum
<b>Potentiometer shaft</b>	Stainless steel
<b>Roller and spring sleeve</b>	Glass filled nylon
<b>Base plate</b>	Zinc plated steel
<b>Springs</b>	Stainless steel

*Mechanical ratings*

<b>Pedal angle (toeboard angle)</b>	28° (16° to 25°) 35° (6° to 15°) 45° (0° to 5°)
<b>Activation force</b>	Typical: 2.3 Kg [5 lbs] (at start) 5.5 Kg [12 lbs] (at full travel)
<b>Activations, full stroke</b>	Minimum: 3 million

*Signal output*

<b>Signal current</b>	Maximum: 20 mA
<b>Idle position</b>	Minimum: 10% ± 2%
<b>Full pedal stroke</b>	Maximum: 90% + 2%, - 7%
<b>Pedal potentiometer resistance</b>	2500 ± 500 Ohms, plus a 1K internal current limiting resistor

## Technical Information    KEP Foot Pedal

### Technical data

#### Bi-directional model type

##### *Electrical and environmental specifications*

<b>Supply voltage (Ucc1, Ucc2)</b> <b>Current consumption (each Hall element)</b>	5 Vdc $\pm$ 0.5 Vdc Maximum: 10 mA (for both Hall elements 20 mA)
<b>Operating temperature</b>	-40 to +85° C [-40 to +185° F]
<b>Sealing of electronics</b>	IP 66

##### *Material*

<b>Casting</b>	Iridited aluminum
<b>Hall element shaft</b>	Stainless steel
<b>Base plate</b>	Zinc plated steel
<b>Spring</b>	Stainless steel
<b>Weight</b>	Typical: 2.6 Kg [5.6 lbs]

##### *Mechanical ratings*

<b>Pedal angle (toeboard angle)</b>	Maximum: 14° $\pm$ 2°
<b>Activations (full stroke)</b>	Minimum: 3 million
<b>Static load limit (forward or reverse)</b>	Maximum: 1500 N (measured 150 mm from pivot)
<b>Side load limit</b>	Maximum: 500 N (measured 150 mm from pivot)
<b>Vertical load limit (neutral)</b>	Maximum: 1000 N (measured center of treadle on pivot axis)

##### *Signal output*

<b>Signal current (APS1, APS2)</b>	Maximum: 0.5 mA
<b>Signal load</b>	Maximum: 10 K Ohms
<b>Short circuit of signal (APS1, APS2)</b>	Maximum: 20 minutes

##### *Option 1, signal level*

<b>Signal 1 range nominal (APS1)</b>	90% +2% and -4% A 10% +4% and -2% B
<b>Signal 2 range nominal (APS2)</b>	10% +4% and -2% A 90% +2% and -4% B
<b>Neutral 1 range nominal (APS1)</b>	50% $\pm$ 4%
<b>Neutral 2 range nominal (APS2)</b>	50% $\pm$ 4%

##### *Option 2, signal level*

<b>Signal 1 range nominal (APS1)</b>	10% +4% and -2% A 80% +2% and -4% B
<b>Signal 2 range nominal (APS2)</b>	20% +4% and -2% A 90% +2% and -4% B
<b>Neutral 1 range nominal (APS1)</b>	45% $\pm$ 4%
<b>Neutral 2 range nominal (APS2)</b>	55% $\pm$ 4%



**Technical Information    KEP Foot Pedal**

**Dimensions**

**Uni-directional model type**

*Part number KEPA14181 (mm [in])*

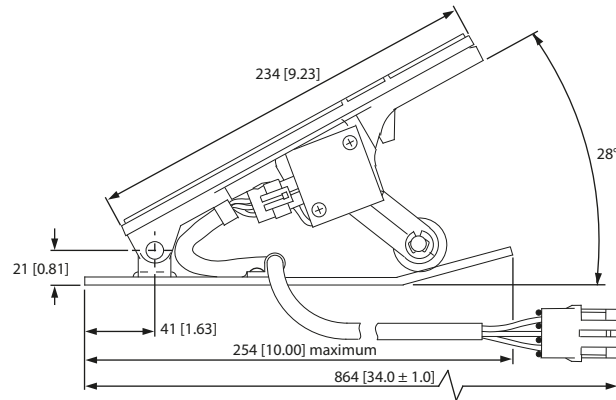

*Part number KEPA14161 (mm [in])*

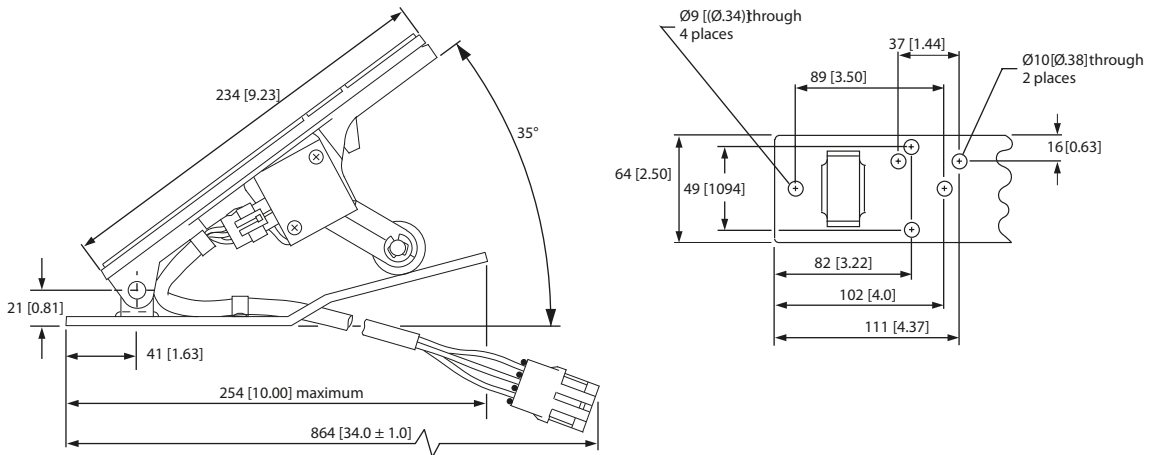

*Part number KEPA14171 (mm [in])*

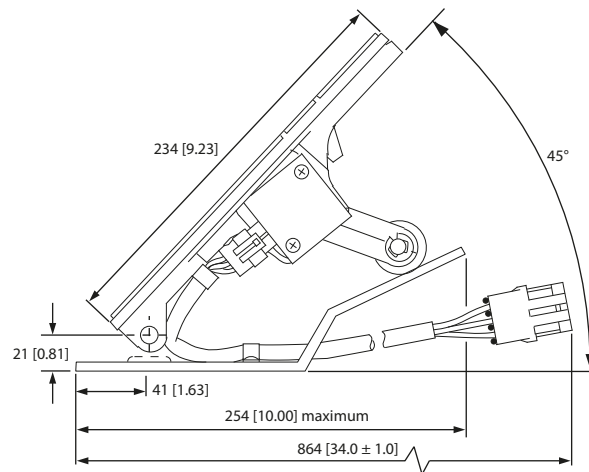

**Dimensions**

**Bi-directional model type**

*A and B direction; full fore and full aft 14° ±2°; dimensions are in mm [in]*

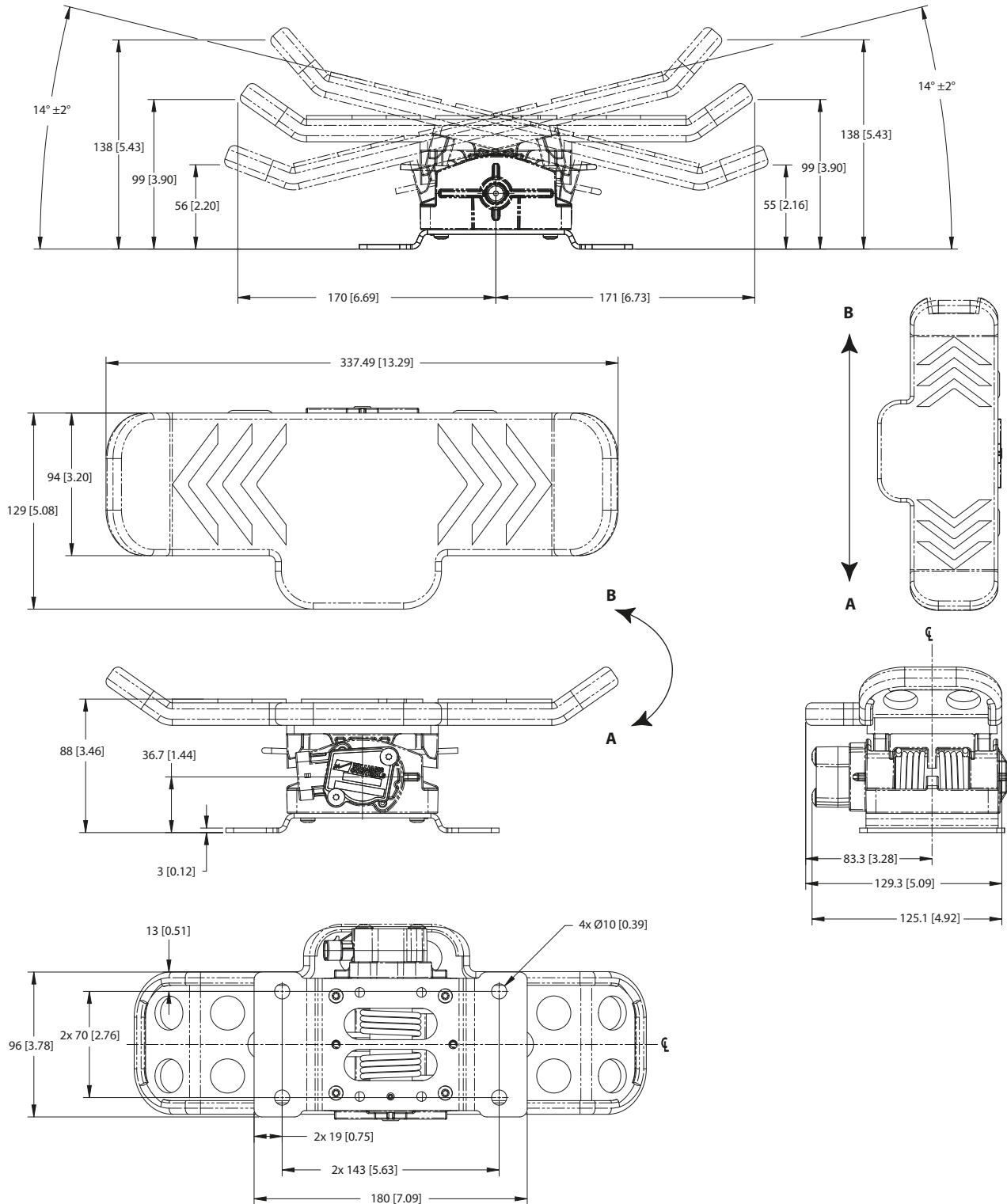

**Output characteristics**

**Uni-directional model type**

*Output and supply voltage - Idle to full pedal stroke*

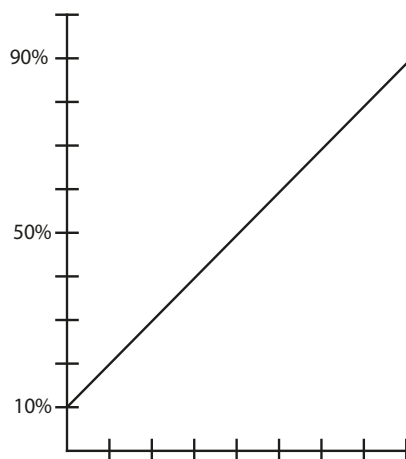

**Bi-directional model type**

*Option 1, 10% to 90% and 90% to 10%*

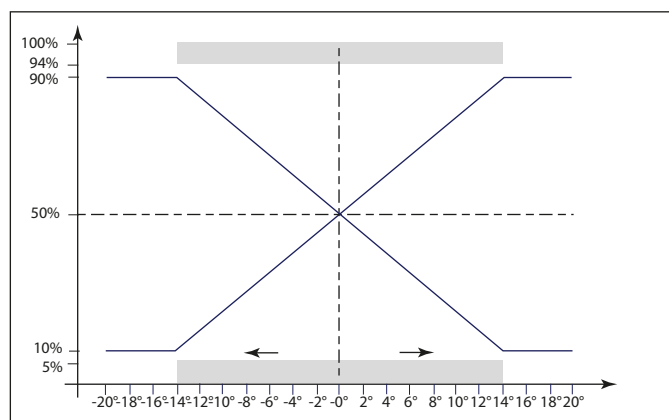

<b>Left of vertical dashed line</b>	Direction A	<b>Right of vertical dashed line</b>	Direction B
<b>Horizontal dashed line</b>	Neutral position	<b>Shaded areas</b>	Fault area
<b>Above neutral position</b>	Sensor 1 output (percent of input voltage)	<b>Horizontal line with arrow</b>	Pedal angle
<b>Below neutral position</b>	Sensor 2 output (percent of input voltage)		

**Output characteristics**

*Option 2, 20% to 90% and 10% to 80%*

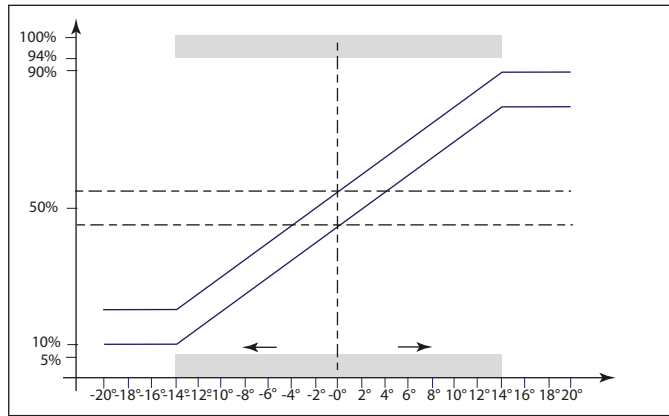

<b>Left of vertical dashed line</b>	Direction A	<b>Right of vertical dashed line</b>	Direction B
<b>Two horizontal dashed lines</b>	Neutral positions	<b>Shaded areas</b>	Fault area
<b>Above neutral position</b>	Sensor 2 output (percent of input voltage)	<b>Horizontal line with arrow</b>	Pedal angle
<b>Below neutral position</b>	Sensor 1 output (percent of input voltage)		

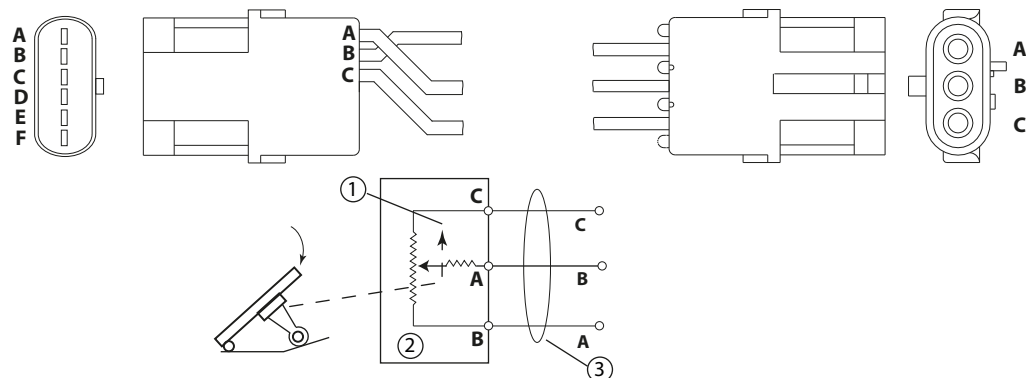
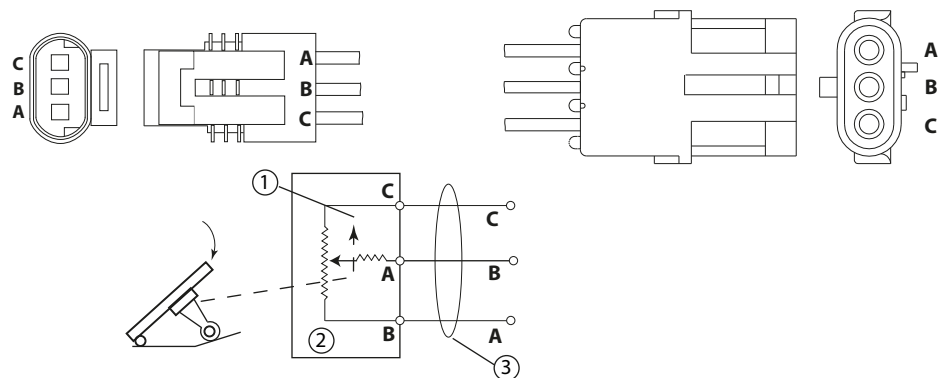
**Electrical connections**
**Uni-directional model type**
**Connector mounted on potentiometer sensor.**
*Current configuration*

*Configuration before February 2006*

- |          |               |          |                  |
|----------|---------------|----------|------------------|
| <b>1</b> | Full stroke   | <b>A</b> | White wire color |
| <b>2</b> | Potentiometer | <b>B</b> | Black wire color |
| <b>3</b> | Cable         | <b>C</b> | Red wire color   |

*PLUS+1® module pin connections example*

Pin	Sensor	Connector
Power ground -	Not used	Not used
Power supply +	Not used	Not used
Sensor power +	C	C
Sensor power -	B	A
AIN/CAN0 shield	A	B
AIN/CAN1 shield	A	B
DIN	Not used	Not used
DIN/AIN	A	B
DIN/AIN/FreqIN	A	B
AIN/Temp/Rheo	A	B

**Technical Information    KEP Foot Pedal**

**Electrical connections**

**Bi-directional model type**

*Metri-Pack Series 150 (view facing connector end)*

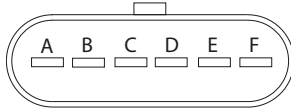

<b>Housing part number</b>	12066317
<b>Terminal part number</b>	12103881

*Sensor connections*

Pin	Function	Wire color
A	Signal 1 = Us1	Black
B	Ground 1 = GND1	White
C	Supply 1 = Ucc1	Red
D	Supply 2 = Ucc2	Green
E	Ground 2 = GND2	Blue
F	Signal 2 = Us2	Orange

**Wiring harness**

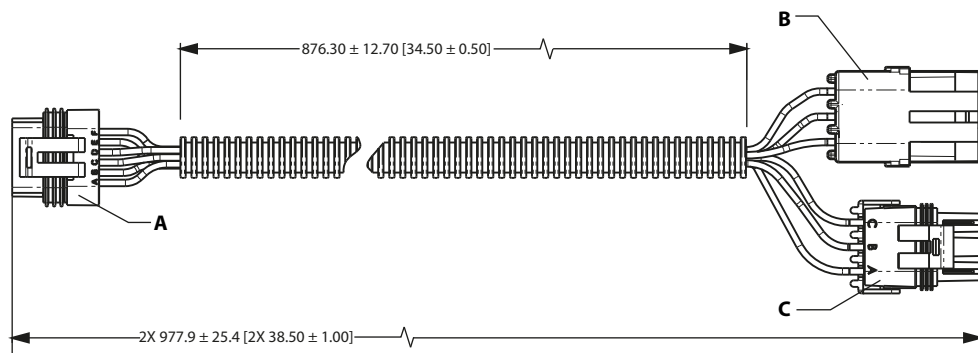

- A**    Metri-Pack 150 Series Connector
- B**    Weather Pack Connector (Shroud)
- C**    Weather Pack Connector (Tower)

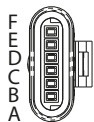
**Electrical connections**
**Connector A: Metri-Pack connector**

Pin	Function	Wire color
A	Signal 1 = Us1	Black
B	Ground 1 = GND1	White
C	Supply 1 = Ucc1	Red
D	Supply 2 = Ucc2	Green
E	Ground 2 = GND2	Blue
F	Signal 2 = Us2	Orange

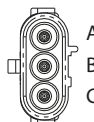
**Connector B: Weather Pack connector (shroud)**

Pin	Function	Wire color
A	Ground 1 = GND1	White
B	Signal 1 = Us1	Black
C	Supply 1 = Ucc1	Red

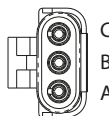
**Connector C: Weather Pack connector (tower)**

Pin	Function	Wire color
C	Supply 2 = Ucc2	Green
B	Ground 2 = GND2	Blue
A	Signal 2 = Us2	Orange

Electrical connections

Schematics of a foot pedal connected to a PLUS+1® module

**Example, part 1**

Example of connecting foot pedal to a PLUS+1® module, part 1

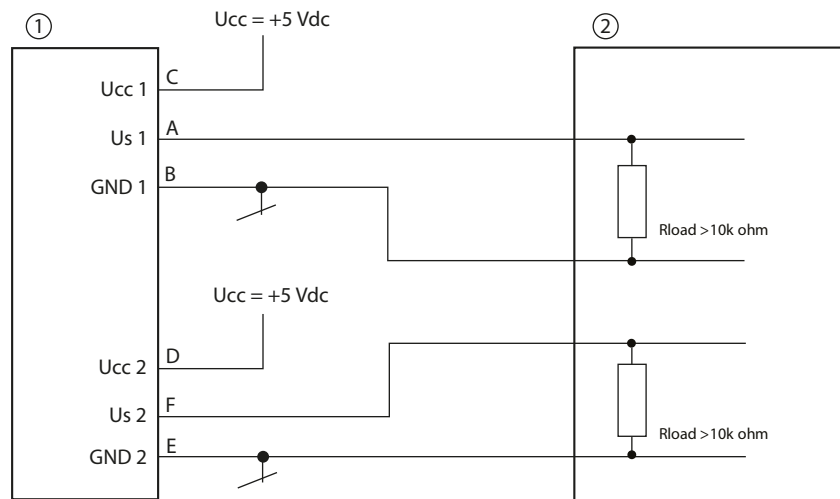

1	Sensor
2	Controller

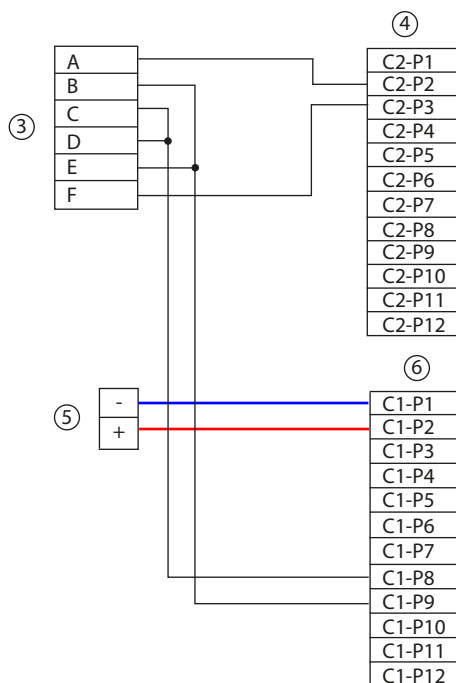

**Electrical connections**
**Example, part 2**

3	Footpedal		4	Connector 2			
	Pin	Function		Pin	Controller function	Pin	Controller function
	<b>A</b>	Signal 1 = Us1		<b>C2-P1</b>	DIN	<b>C2-P7</b>	AIN/Temp/Rheo
	<b>B</b>	Ground 1 = GND1		<b>C2-P2</b>	DIN/AIN/FreqIN	<b>C2-P8</b>	AIN/Temp/Rheo
	<b>C</b>	Supply 1 = Ucc1		<b>C2-P3</b>	DIN/AIN/FreqIN	<b>C2-P9</b>	PWMOUT/DOUT/PVGOUT
	<b>D</b>	Supply 2 = Ucc2		<b>C2-P4</b>	DIN/AIN/FreqIN	<b>C2-P10</b>	PWMOUT/DOUT/PVGOUT
	<b>E</b>	Ground 2 = GND2		<b>C2-P5</b>	DIN/AIN/FreqIN	<b>C2-P11</b>	PWMOUT/DOUT/PVGOUT
	<b>F</b>	Signal 2 = Us2		<b>C2-P6</b>	DIN/AIN/FreqIN	<b>C2-P12</b>	PWMOUT/DOUT/PVGOUT

5	Power supply		6	Connector 1			
	-	+		Pin	Controller function	Pin	Controller function
	12/24 Vdc	12/24 Vdc		<b>C1-P1</b>	Power ground -	<b>C1-P7</b>	DIN
				<b>C1-P2</b>	Power supply +	<b>C1-P8</b>	5 Vdc sensor power +
				<b>C1-P3</b>	CAN +	<b>C1-P9</b>	Sensor power ground -
				<b>C1-P4</b>	CAN -	<b>C1-P10</b>	DIN
				<b>C1-P5</b>	AIN/CAN shield	<b>C1-P11</b>	DIN
				<b>C1-P6</b>	DIN	<b>C1-P12</b>	DIN

**Electrical connections****PLUS+1® module pin connections example**

<b>Pin</b>	<b>Sensor</b>
Power ground -	Not used
Power supply +	Not used
Sensor power +	C, D
Sensor power -	B, E
AIN/CAN0 shield	A, F
AIN/CAN1 shield	A, F
DIN	Not used
DIN/AIN	A, F
DIN/AIN/FreqIN	A, F
AIN/Temp/Rheo	A, F





**Products we offer:**

- Bent Axis Motors
- Closed Circuit Axial Piston Pumps and Motors
- Displays
- Electrohydraulic Power Steering
- Electrohydraulics
- Hydraulic Power Steering
- Integrated Systems
- Joysticks and Control Handles
- Microcontrollers and Software
- Open Circuit Axial Piston Pumps
- Orbital Motors
- PLUS+1® GUIDE
- Proportional Valves
- Sensors
- Steering
- Transit Mixer Drives

**Danfoss Power Solutions** is a global manufacturer and supplier of high-quality hydraulic and electronic components. We specialize in providing state-of-the-art technology and solutions that excel in the harsh operating conditions of the mobile off-highway market. Building on our extensive applications expertise, we work closely with our customers to ensure exceptional performance for a broad range of off-highway vehicles.

We help OEMs around the world speed up system development, reduce costs and bring vehicles to market faster.

Danfoss – Your Strongest Partner in Mobile Hydraulics.

**Go to [www.powersolutions.danfoss.com](http://www.powersolutions.danfoss.com) for further product information.**

Wherever off-highway vehicles are at work, so is Danfoss. We offer expert worldwide support for our customers, ensuring the best possible solutions for outstanding performance. And with an extensive network of Global Service Partners, we also provide comprehensive global service for all of our components.

Please contact the Danfoss Power Solution representative nearest you.

**Comatrol**

[www.comatrol.com](http://www.comatrol.com)

**Schwarzmueller-Inverter**

[www.schwarzmueller-inverter.com](http://www.schwarzmueller-inverter.com)

**Turolla**

[www.turollaocg.com](http://www.turollaocg.com)

**Hydro-Gear**

[www.hydro-gear.com](http://www.hydro-gear.com)

**Daikin-Sauer-Danfoss**

[www.daikin-sauer-danfoss.com](http://www.daikin-sauer-danfoss.com)

Local address:

**Danfoss Power Solutions (US) Company**  
2800 East 13th Street  
Ames, IA 50010, USA  
Phone: +1 515 239 6000

**Danfoss Power Solutions GmbH & Co. OHG**  
Krokamp 35  
D-24539 Neumünster, Germany  
Phone: +49 4321 871 0

**Danfoss Power Solutions ApS**  
Nordborgvej 81  
DK-6430 Nordborg, Denmark  
Phone: +45 7488 2222

**Danfoss Power Solutions Trading (Shanghai) Co., Ltd.**  
Building #22, No. 1000 Jin Hai Rd  
Jin Qiao, Pudong New District  
Shanghai, China 201206  
Phone: +86 21 3418 5200

Danfoss can accept no responsibility for possible errors in catalogues, brochures and other printed material. Danfoss reserves the right to alter its products without notice. This also applies to products already on order provided that such alterations can be made without changes being necessary in specifications already agreed. All trademarks in this material are property of the respective companies. Danfoss and the Danfoss logotype are trademarks of Danfoss A/S. All rights reserved.