

**Revision View**

Date	Page	Changed	Revision
Apr 2008	Many	Pictures, drawings and text	AB
Jul 2008	Various	Text	AC
Mar 2010	36	Japan location	AE
Sep 2010	36	New back page	AF
May 2011	20	Typos	AG
Oct 2011	30-31	Dimensions added to drawing	AH

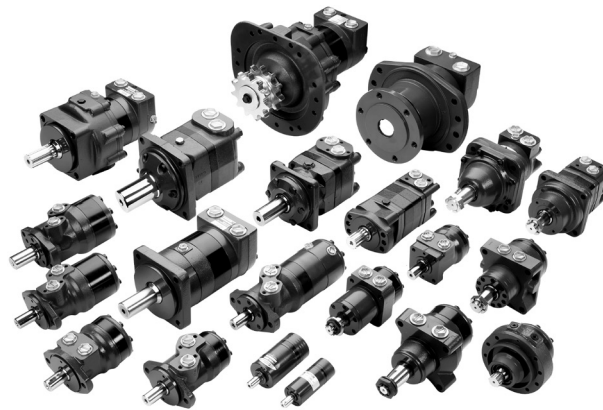

F301 245

**A Wide Range of Orbital Motors**

Sauer-Danfoss is a world leader within production of low speed orbital motors with high torque. We can offer more than 3000 different orbital motors, categorised in types, variants and sizes (incl. different shaft versions).

The motors vary in size (rated displacement) from 8 cm<sup>3</sup> (0.50 in<sup>3</sup>) to 800 cm<sup>3</sup> (48.9 in<sup>3</sup>) per revolution.

Speeds range up to approx. 2500 min<sup>-1</sup> (rpm) for the smallest type and up to approx 600 min<sup>-1</sup> (rpm) for the largest type.

Maximum operating torques vary from 13 Nm (115 lbf-in] to 2700 Nm (24.000 lbf-in] (peak) and maximum outputs are from 2.0 kW (2.7 hp] to 70 kW (95 hp].

Characteristic features:

- Smooth running over the entire speed range
- Constant operating torque over a wide speed range
- High starting torque
- High return pressure without the use of drain line (High pressure shaft seal)
- High efficiency
- Long life under extreme operating conditions
- Robust and compact design
- High radial and axial bearing capacity

© 2011 Sauer-Danfoss. All rights reserved.

Sauer-Danfoss accepts no responsibility for possible errors in catalogs, brochures and other printed material. Sauer -Danfoss reserves the right to alter its products without prior notice. This also applies to products already ordered provided that such alterations can be made without affecting agreed specifications. All trademarks in this material are properties of their respective owners. Sauer-Danfoss, the Sauer-Danfoss logotype, the Sauer-Danfoss S-Icon, PLUS+1™, What really matters is inside® and Know-How in Motion™ are trademarks of the Sauer-Danfoss Group.

Frontpage: F300 029, F300 044, F300 028, F300 045, Drawing P301 017

## OML and OMM Technical Information A Wide Range of Orbital Motors

- For applications in both open and closed loop hydraulic systems
- Suitable for a wide variety of hydraulics fluids

The programme is characterised by technical features appealing to a large number of applications and a part of the programme is characterised by motors that can be adapted to a given application. Adaptions comprise the following variants among others:

- Motors with corrosion resistant parts
- Wheel motors with recessed mounting flange
- OMP, OMR- motors with needle bearing
- OMR motor in low leakage version
- OMR motors in a super low leakage version
- Short motors without bearings
- Ultra short motors
- Motors with integrated positive holding brake
- Motors with integrated negative holding brake
- Motors with integrated flushing valve
- Motors with speed sensor
- Motors with tacho connection
- All motors are available with black finish paint

### *Planetary gears*

Sauer - Danfoss complements the motor range with a complete programme of planetary gears adapted to suit. The combination of motors and gears makes it possible to obtain smooth running at fractional speeds and with torques up to 650.000 Nm (5.800.000 lbf-in).

The Sauer–Danfoss LSHT motors are used in the following application areas:

- Construction equipment
- Agricultural equipment
- Material handling & Lifting equipment
- Forestry equipment
- Lawn and turf equipment
- Special purpose
- Machine tools and stationary equipment
- Marine equipment

### **Survey of Literature with Technical Data on Sauer-Danfoss Orbital Motors**

Detailed data on all Sauer-Danfoss orbital motors can be found in our motor catalogue, which is divided into more individual subcatalogues:

- General information on Sauer-Danfoss orbital motors: function, use, selection of orbital motor, hydraulic systems, etc.
- Technical data on small motors: OML and OMM
- Technical data on medium sized motors: OMP, OMR, OMH and OMEW
- Technical data on medium sized motors: DH and DS
- Technical data on large motors: OMS, OMT and OMV
- Technical data on large motors: TMT

A general survey brochure on Sauer-Danfoss orbital motors gives a quick motor reference based on power, torque, speed and capabilities.

**Contents**

OML and OMM ..... 4  
 Speed, Torque and Output ..... 4

OML ..... 6  
 Versions ..... 6  
 Code Numbers ..... 7  
 Technical Data for OML with 16 mm and 5/8 in Cylindrical Shaft ..... 8  
 Technical Data ..... 8  
 Max. Permissible Shaft Seal Pressure ..... 9  
 Pressure Drop in Motor ..... 9  
 Direction of Shaft Rotation ..... 10  
 Permissible Shaft Loads for OML ..... 10  
 Function Diagrams ..... 11  
 Shaft Version ..... 13  
 Port Thread Versions ..... 14  
 Dimensions ..... 15

OMM ..... 18  
 Versions ..... 18  
 Code Numbers ..... 19  
 Technical Data for OMM with 16 mm and 5/8 in Cylindrical Shaft ..... 20  
 Technical Data ..... 20  
 Max. Permissible Shaft Seal Pressure ..... 21  
 Pressure Drop in Motor ..... 21  
 Direction of Shaft Rotation ..... 22  
 Permissible Shaft Loads for OMM ..... 22  
 Function Diagrams ..... 23  
 Shaft Version ..... 26  
 Port Thread Versions ..... 27  
 Dimensions ..... 28  
 Accessories ..... 32

Hydraulic Systems ..... 35  
 Installation of the Sauer-Danfoss Orbital Motors ..... 35  
 Starting Up and Running in the Hydraulic System ..... 35  
 Operation ..... 35  
 Maintenance ..... 35  
 Hydraulic Systems ..... 35

**Speed, Torque and Output**

The bar diagrams, see page 5, are useful for a quick selection of relevant motor size for the application. The final motor size can be determined by using the function diagram for each motor size.

- OML can be found on pages 11 - 12
- OMM can be found on pages 23 - 25

The function diagrams are based on actual tests on a representative number of motors from our production. The diagrams apply to a return pressure between 5 and 10 bar [75 and 150 psi] when using mineral based hydraulic oil with a viscosity of 35 mm<sup>2</sup>/s [165 SUS] and a temperature of 50°C [120°F]. For further explanation concerning how to read and use the function diagrams, please consult the paragraph "Selection of motor size" in the technical information "General" DKMH.PK.100.G2.02 520L0232.

**Speed, Torque and Output**

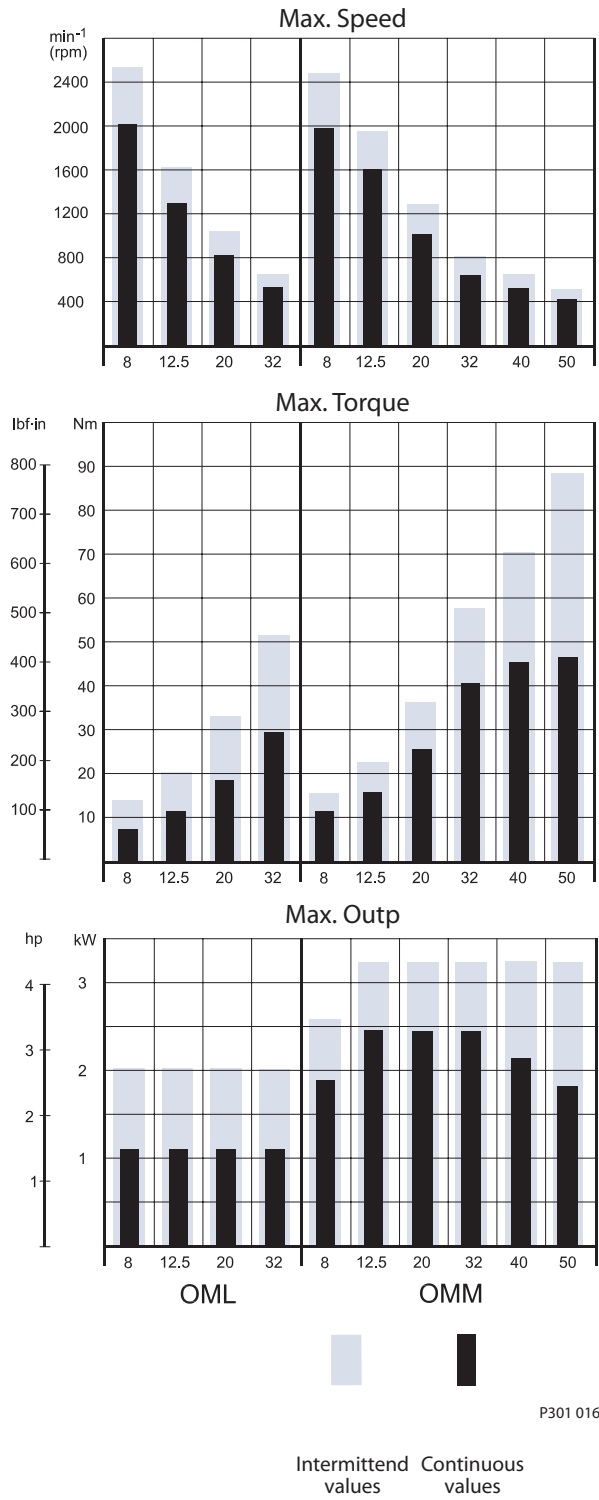

P301 016

Versions

Mounting	Shaft	Port size	European version	US version	Side port version	End port version	Standard shaft seal	Drain connection	Check valve	Specials	Main type designation
Front, 4 × M5	Cyl. 16 mm	G 1/4	X			X	X	No	Yes		OML
Front, 4 × 10-32 UNF	Cyl. 5/8 in	7/16 - 20 UNF		X		X	X	No	Yes		OML

Function diagram - see page : →

Features available (options) :  
 Painted

### Code Numbers

Code Numbers	DISPLACEMENT (cm <sup>3</sup> )				Technical data – Page	Dimensions – Page
	8	12.5	20	32		
<b>151G</b>	2001	2002	2003	2004	8	15
<b>151G</b>	2021	2022	2023	2024	8	16
→	11	11	12	12		

### Ordering

Add the four digit prefix “151G” to the four digit numbers from the chart for complete code number.

Example:

151G2001 for an OML 8 with front mounting (4 × M5), cyl. 16 mm shaft and port size G 1/4.

---

Note: Orders will not be accepted without the four digit prefix.

---

**Technical Data for OML with 16 mm and 5/8 in Cylindrical Shaft**

Type		OML	OML	OML	OML
Motor Size		8	12.5	20	32
Geometric displacement	cm <sup>3</sup> [in <sup>3</sup> ]	8.0 [0.49]	12.5 [0.77]	20.0 [1.22]	32.0 [1.96]
Max. speed	min <sup>-1</sup> [rpm]	cont.	2000	1280	800
		int. <sup>1)</sup>	2500	1600	1000
Max. torque	Nm [lbf·in]	cont.	7 [60]	11 [100]	18 [160]
		int. <sup>1)</sup>	13 [120]	20 [180]	32 [280]
Max. output	kW [hp]	cont.	1.1 [1.5]	1.1 [1.5]	1.1 [1.5]
		int. <sup>1)</sup>	2.0 [2.7]	2.0 [2.7]	2.0 [2.7]
Max. pressure drop	bar [psi]	cont.	70 [1020]	70 [1020]	70 [1020]
		int. <sup>1)</sup>	125 [1810]	125 [1810]	125 (85) <sup>3</sup> [1810] [800] <sup>3</sup>
		peak <sup>2)</sup>	140 [2030]	140 [2030]	125 (85) <sup>3</sup> [2030] [1230] <sup>3</sup>
Max. oil flow	l/min [USgal/min]	cont.	16 [4.2]	16 [4.2]	16 [4.2]
		int. <sup>1)</sup>	20 [5.3]	20 [5.3]	20 [5.3]
Max. starting pressure with unloaded shaft	bar [psi]	4 [60]	4 [60]	4 [60]	6 [90]
Min. starting torque	at max. press. drop cont.	5 [45]	9 [80]	15 [135]	24 [210]
	at max. press. drop int. <sup>1)</sup>	10 [90]	16 [140]	27 [240]	42 [370]
Min. speed <sup>4)</sup>	min <sup>-1</sup> [rpm]	50	50	50	50

Type	Max. Inlet Pressure	
OML 8 - 32	bar [psi]	cont. 125 [1810]
	bar [psi]	int. <sup>1)</sup> 140 [2030]
	bar [psi]	peak <sup>2)</sup> 140 [2030]

<sup>1)</sup> Intermittent operation: the permissible values may occur for max. 10% of every minute.

<sup>2)</sup> Peak load: the permissible values may occur for max. 1% of every minute.

<sup>3)</sup> Max. pressure drop in applications with a large moment of inertia and frequent stops or reversings.

<sup>4)</sup> Operation at lower speed may be slightly less smooth.



**Max. Permissible Shaft Seal Pressure**

**OML has incorporated check valves** which ensure that the pressure on the shaft seal never exceeds the pressure in the returnline

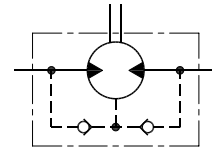

151-1316.10

*Max. return pressure (max. pressure on shaft seal)*

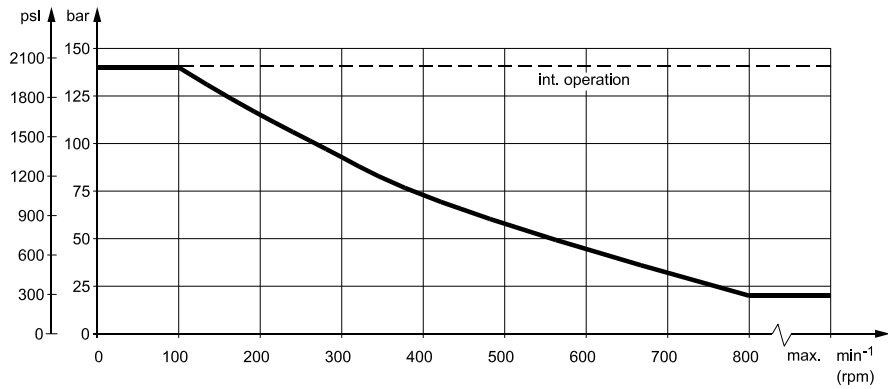

151-1671.10

**Pressure Drop in Motor**

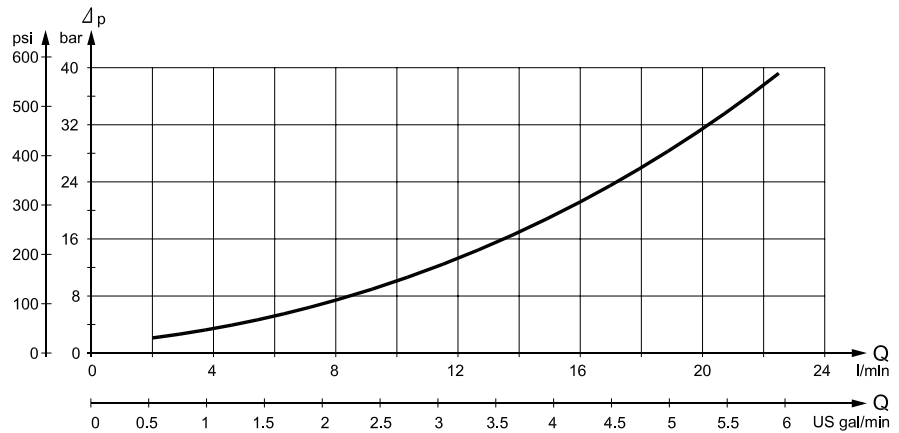

151-1415.10

The curve applies to an unloaded motor shaft and an oil viscosity of 35 mm<sup>2</sup>/s [165 SUS]

**Direction of Shaft Rotation**

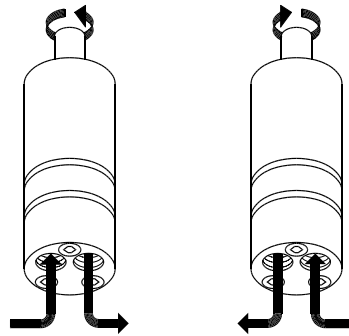

151-1309.10

**Permissible Shaft Loads for OML**

The permissible radial shaft load ( $P_{rad.}$ ) is calculated from the distance ( $l$ ) between the point of load and the mounting surface:

$$P_{rad.} = \frac{84500}{64.5 + l} \text{ N (l in mm; } l \leq 80)$$

$$P_{rad.} = \frac{748}{254 + l} \text{ lbf (l in inch; } l \leq 3.15)$$

The drawing shows the permissible radial load when  $l = 15 \text{ mm [0.59 in]}$ .

The calculated shaft load should never exceed the permissible value.

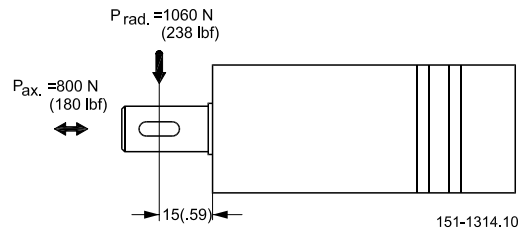

Function Diagrams

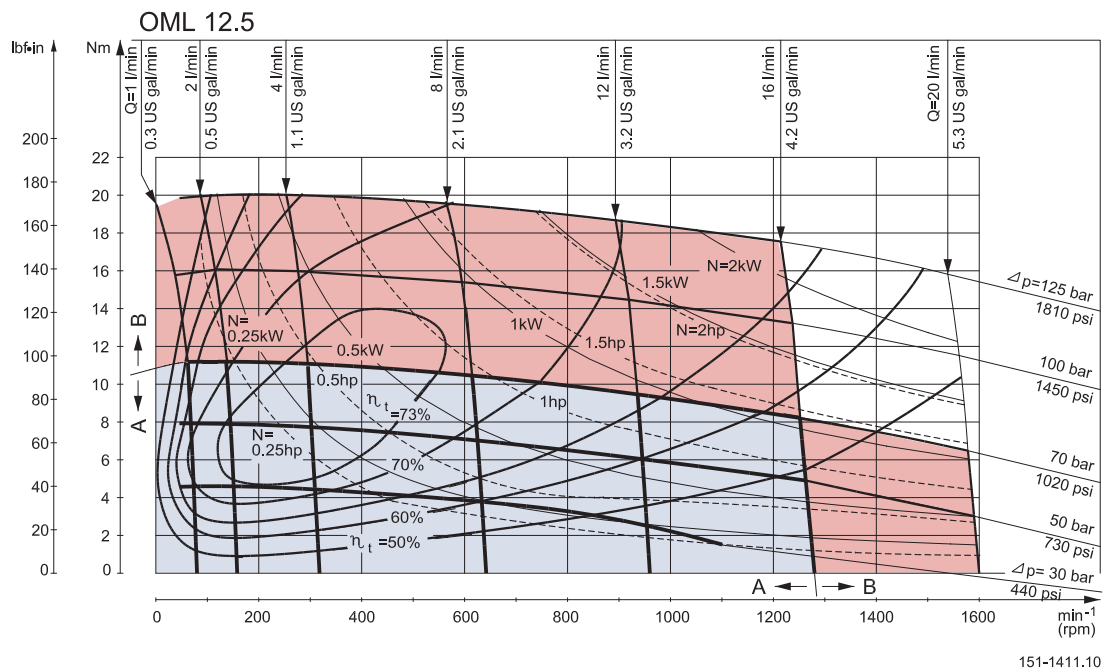
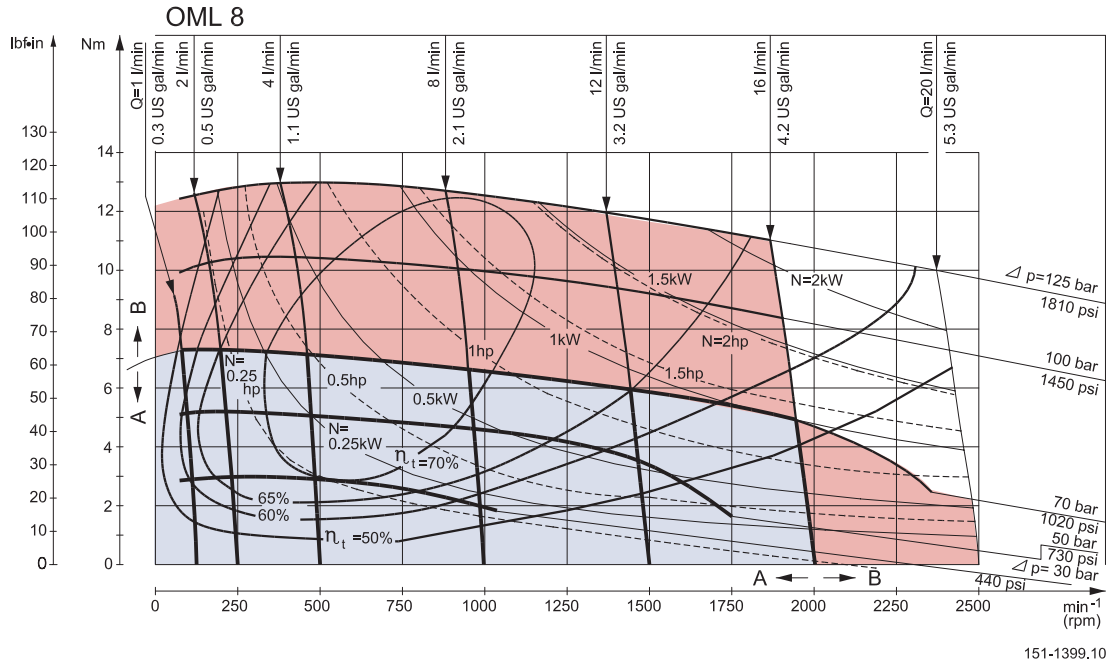

Explanation of function diagram use, basis and conditions can be found on page 4.

- A: Continuous range
- B: Intermittent range (max. 10% operation every minute)

Max. permissible continuous/intermittent pressure drop for the actual shaft version can be found on page 8.

Note: Intermittent pressure drop and oil flow must not occur simultaneously.

Function Diagrams

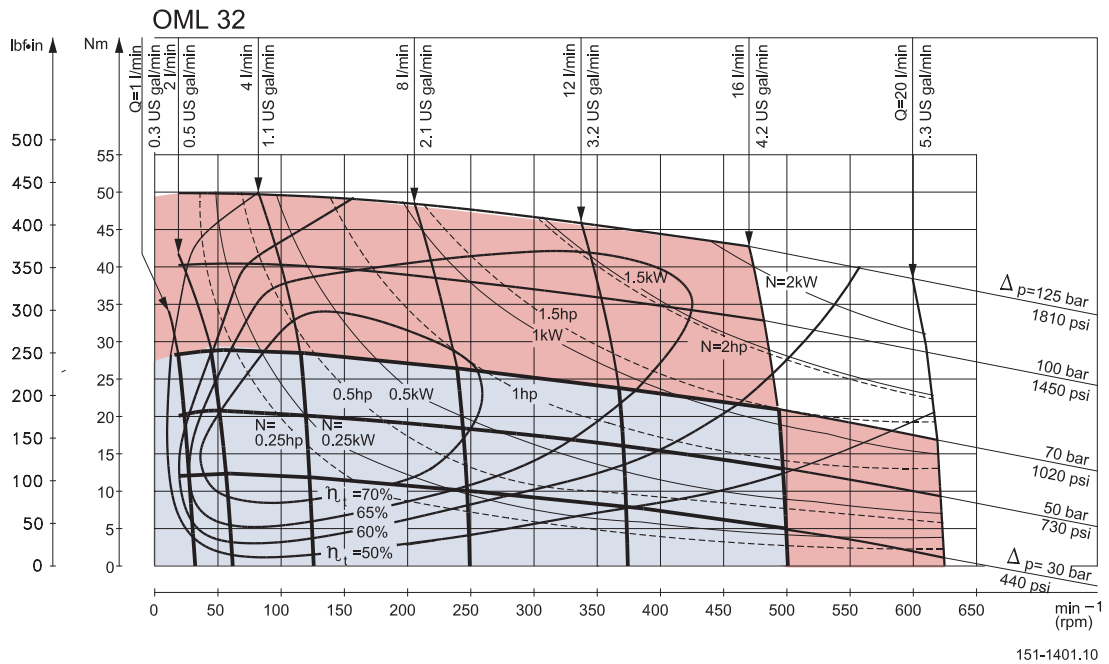
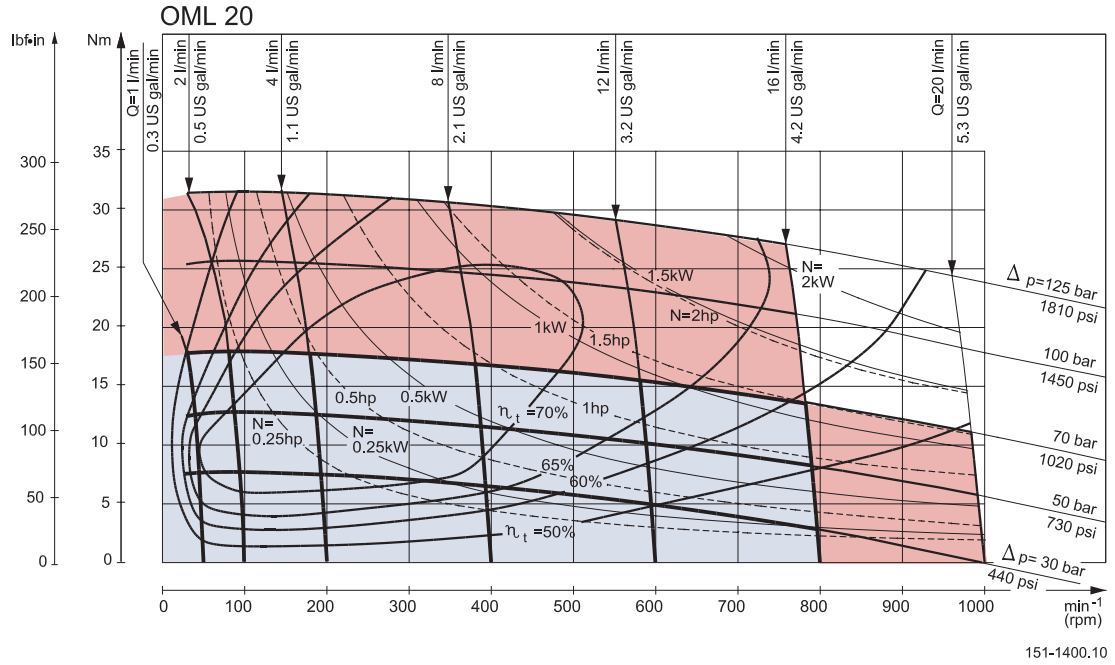

Explanation of function diagram use, basis and conditions can be found on page 4.

- A: Continuous range
- B: Intermittent range (max. 10% operation every minute)

Max. permissible continuous/intermittent pressure drop for the actual shaft version can be found on page 8.

Note: Intermittent pressure drop and oil flow must not occur simultaneously.

**Shaft Version**

- A: Cylindrical shaft  
 16 mm
- C: Parallel key  
 A5 × 5 × 16  
 DIN 6885

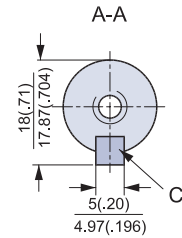
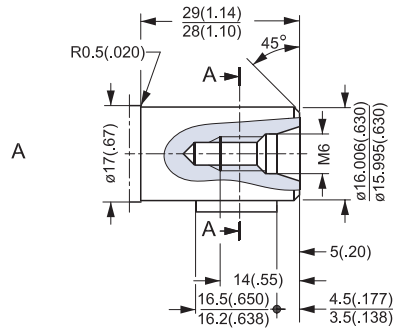

**US version**

- B: Cylindrical shaft  
 $\frac{5}{8}$ "
- D: Parallel key  
 $\frac{3}{16} \times \frac{3}{16} \times \frac{3}{4}$  in  
 B.S. 46

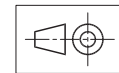
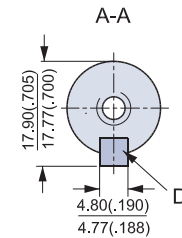
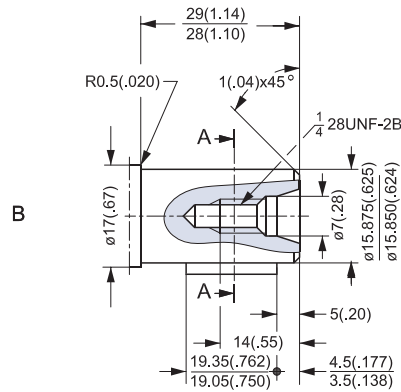

151-1865.10

**Port Thread Versions**

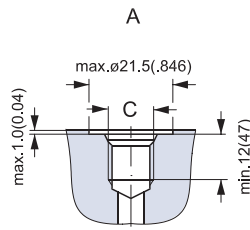

A: G main ports  
C: ISO 228/1 - G $\frac{1}{4}$

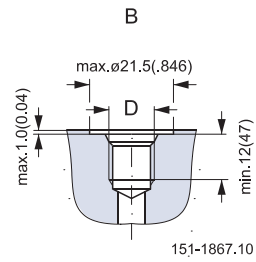

B: UNF main ports  
D:  $\frac{7}{16}$  - 20 UNF  
O-ring boss port

**Dimensions**

OML  
 End port version.

Type	Length		Weight kg [lb]
	L <sub>max.</sub>	L <sub>1</sub> mm [in]	
OML 8	102.5 [4.04]	4.1 [0.16]	1.0 [2.2]
OML 12.5	104.8 [4.13]	6.4 [0.25]	1.0 [2.2]
OML 20	108.6 [4.28]	10.2 [0.40]	1.1 [2.4]
OML 32	114.7 [4.53]	16.3 [0.64]	1.2 [2.6]

C: M5; 15 mm [0.59 in] deep  
 D: G ¼; 12 mm [0.47 in] deep

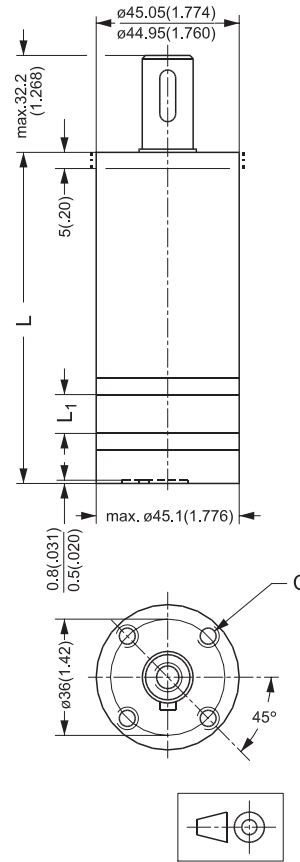
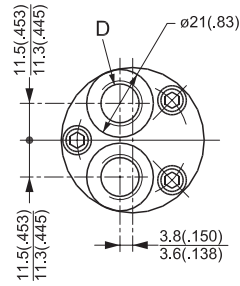

151-1315.10

**Dimensions**

OML  
 End port version.

Type	Length		Weight kg [lb]
	L <sub>max.</sub>	L <sub>1</sub> mm [in]	
OML 8	102.5 [4.04]	4.1 [0.16]	1.0 [2.2]
OML 12.5	104.8 [4.13]	6.4 [0.25]	1.0 [2.2]
OML 20	108.6 [4.28]	10.2 [0.40]	1.1 [2.4]
OML 32	114.7 [4.53]	16.3 [0.64]	1.2 [2.6]

C: 10 - 32 UNF;  
 15 mm [0.59 in] deep  
 D: 7/16 - UNF;  
 12 mm [0.47 in] deep  
 O-ring boss port

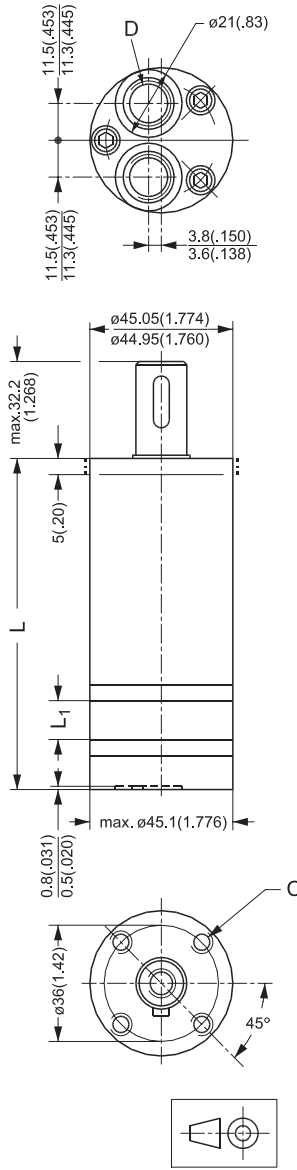

151-1315.10.22





OML and OMM  
Technical Information  
Notes

Notes

Versions

Mounting	Shaft	Port size	European version	US version	Side port version	End port version	Standard shaft seal	Drain connection	Check valve	Specials	Main type designation
Front; 3 × M6	Cyl. 16 mm	G 3/8	X			X	X	Yes	Yes		OMM
		G 3/8	X		X		X	Yes	Yes		OMM
Front; 3 × 1/4 - 28 UNF	Cyl. 5/8 in	9/16-18 UNF		X		X	X	Yes	Yes		OMM
		9/16-18 UNF		X	X		X	Yes	Yes		OMM
Front; 3 × M6	Splined B17×14	G 3/8	X			X	X	Yes	Yes		OMM
		G 3/8	X		X		X	Yes	Yes		OMM

Function diagram - see page : →

*Features available (options) :*

- Speed sensor
- Reverse rotation
- Corrosion protected
- Painted
- 2 bolt flange kit (Code no 151G0211)

**Code Numbers**

Code Numbers	DISPLACEMENT (cm <sup>3</sup> )						Technical data – Page	Dimensions – Page
	8	12.5	20	32	40	50		
<b>151G</b>	0040	0001	0002	0003	0277	0037	20	28
<b>151G</b>	0041	0004	0005	0006	0279	0013	20	30
<b>151G</b>	0048	0031	0032	0033	-	5032	20	29
<b>151G</b>	0049	0034	0035	0036	-	0094	20	31
<b>151G</b>	0046	0024	0025	0026	-	-	20	28
<b>151G</b>	0047	0027	0028	0029	0294	-	20	30
→	23	23	24	24	25	25		

**Ordering**

Add the four digit prefix “151G” to the four digit numbers from the chart for complete code number.

Example:

151G0035 for an OMM 20 with front mounting ( $3 \times \frac{1}{4}$  - 28 UNF), cyl.  $\frac{5}{8}$  in shaft and port size  $\frac{9}{16}$  - 18 UNF.

---

Note: Orders will not be accepted without the four digit prefix.

---

**Technical Data for OMM with 16 mm and 5/8 in Cylindrical Shaft**

Type			OMM	OMM	OMM	OMM	OMM	OMM
Motor Size			8	12.5	20	32	40	50
Geometric displacement	cm <sup>3</sup> [in <sup>3</sup> ]		8.2 [0.50]	12.5 [0.77]	19.9 [1.22]	31.6 [1.93]	39.8 [2.43]	50 [3.08]
Max. speed	min <sup>-1</sup> [rpm]	cont.	1950	1550	1000	630	500	400
		int. <sup>1)</sup>	2450	1940	1250	800	630	500
Max. torque	Nm [lbf·in]	cont.	11 [95]	16 [140]	25 [220]	40 [350]	45 [400]	46 [410]
		int. <sup>1)</sup>	15 [135]	23 [200]	35 [310]	57 [500]	70 [620]	88 [780]
Max. output	kW [hp]	cont.	1.8 [2.4]	2.4 [3.2]	2.4 [3.2]	2.4 [3.2]	2.2 [3.0]	1.8 [2.4]
		int. <sup>1)</sup>	2.6 [3.5]	3.2 [4.3]	3.2 [4.3]	3.2 [4.3]	3.2 [4.3]	3.2 [4.3]
Max. pressure drop	bar [psi]	cont.	100 [1450]	100 [1450]	100 [1450]	100 [1450]	90 [1310]	70 [1020]
		int. <sup>1)</sup>	140 [2030]	140 [2030]	140 [2030]	140 [2030]	140 [2030]	140 [2030]
		peak <sup>2)</sup>	200 [2900]	200 [2900]	200 [2900]	160 [2320]	160 [2320]	160 [2320]
Max. oil flow	l/min [USgal/min]	cont.	16 [4.2]	20 [5.3]	20 [5.3]	20 [5.3]	20 [5.3]	20 [5.3]
		int. <sup>1)</sup>	20 [5.3]	25 [6.6]	25 [6.6]	25 [6.6]	25 [6.6]	25 [6.6]
Max. starting pressure with unloaded shaft	bar [psi]		4 [60]	4 [60]	4 [60]	4 [60]	4 [60]	4 [60]
Min. starting torque	at max. press. drop cont. Nm [lbf·in]		7 [60]	12 [105]	21 [185]	34 [300]	38 [335]	41 [365]
	at max. press. drop int. <sup>1)</sup> Nm [lbf·in]		10 [90]	17 [150]	29 [255]	48 [425]	62 [550]	79 [700]
Min. speed <sup>3)</sup>	min <sup>-1</sup> [rpm]		50	40	30	30	30	30

Type		Max. Inlet Pressure
OMM 8 - 50	bar [psi]	140 [2030]
	bar [psi]	175 [2538]
	bar [psi]	225 [3260]
	bar [psi]	

<sup>1)</sup> Intermittent operation: the permissible values may occur for max. 10% of every minute.

<sup>2)</sup> Peak load: the permissible values may occur for max. 1% of every minute.

<sup>3)</sup> Operation by lower speeds may be slightly less smooth.

**Max. Permissible Shaft Seal Pressure**

**OMM with check valves and without use of drain connection:**

The pressure on the shaft seal never exceeds the pressure in the return line.

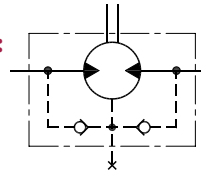

151-320.10

**OMM with check valves and drain connection:**

The shaft seal pressure equals the pressure on the drain line.

*Max. return pressure without drain line or max. pressure in drain line*

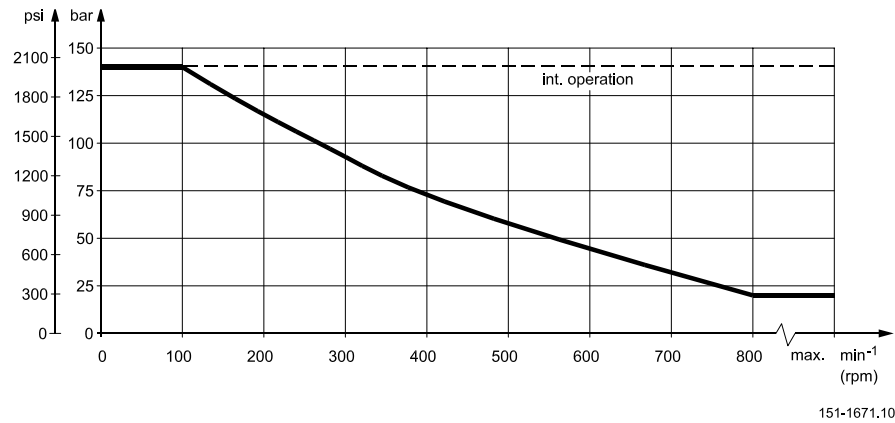

151-1671.10

**Pressure Drop in Motor**

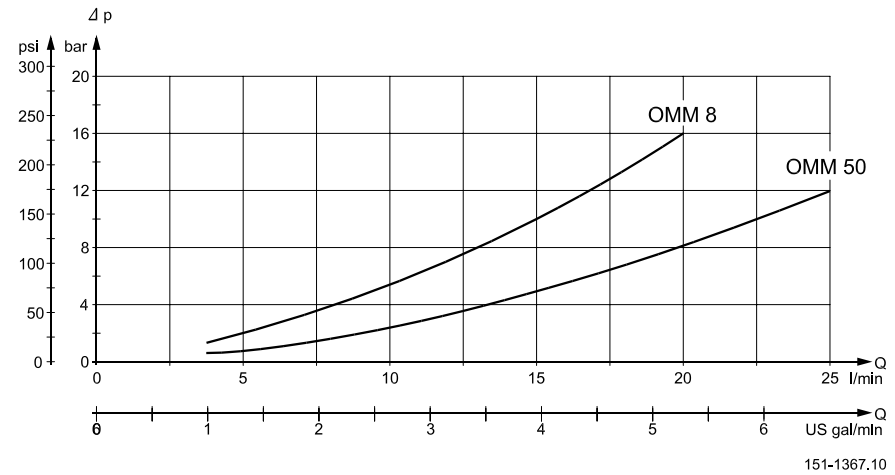

151-1367.10

The curve applies to an unloaded motor shaft and an oil viscosity of 35 mm<sup>2</sup>/s [165 SUS]

**Direction of Shaft Rotation**

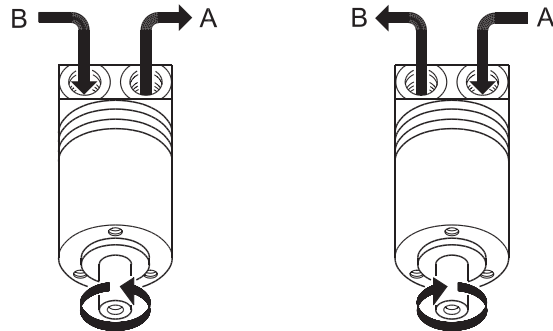

P301 008

**Permissible Shaft Loads for OMM**

The permissible radial shaft load ( $P_{rad.}$ ) is calculated from the distance ( $l$ ) between the point of load and the mounting surface:

$$P_{rad.} = \frac{130400}{61.5 + l} \text{ N (l in mm; } l \leq 80 \text{ mm)}$$

$$P_{rad.} = \frac{748}{2.54 + l} \text{ lbf (l in inch; } l \leq 3.15 \text{ in)}$$

The drawing shows the permissible radial load when  $l = 20 \text{ mm [0.79 in]}$ .

The calculated shaft load should never exceed the permissible value.

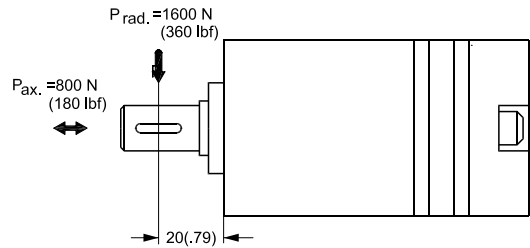

151-980.11

Function Diagrams

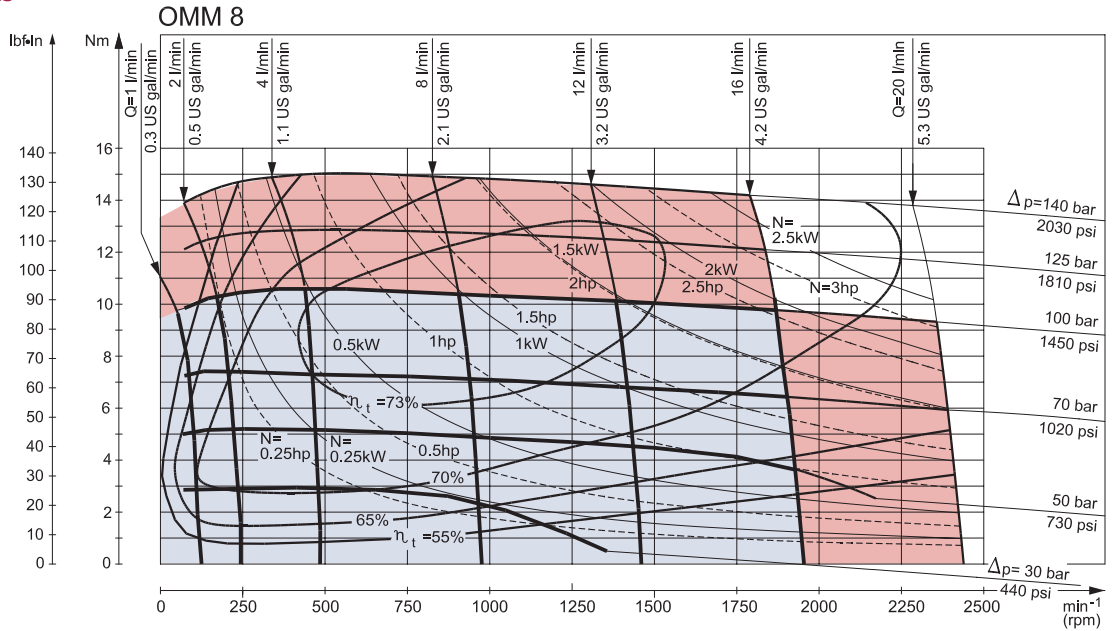

151-1117.11

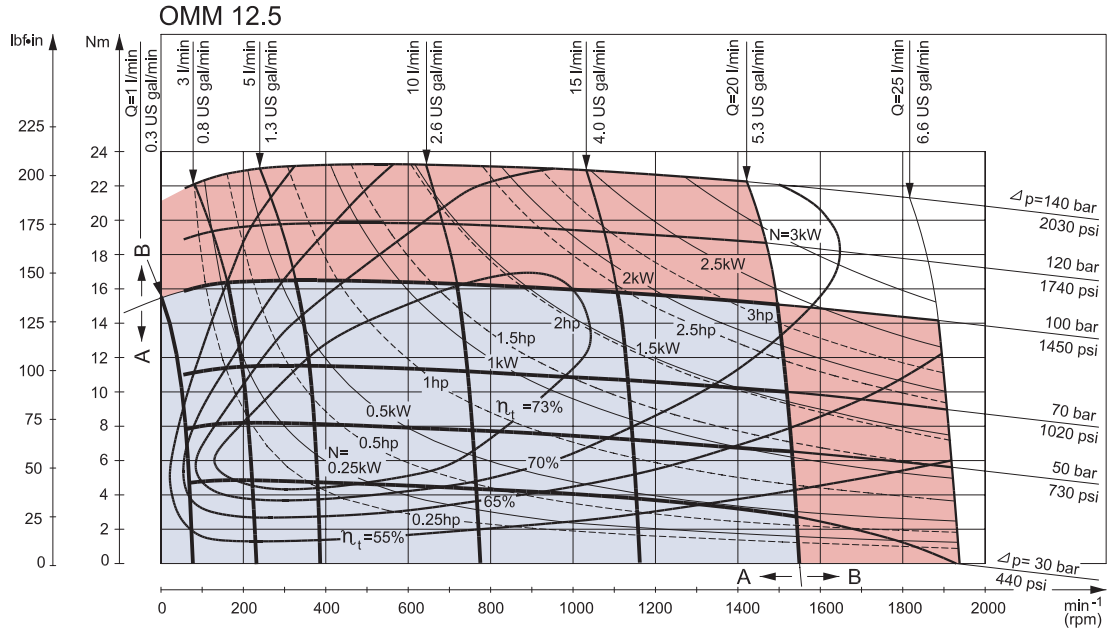

151-994.10

Explanation of function diagram use, basis and conditions can be found on page 4.

- A: Continuous range
- B: Intermittent range (max. 10% operation every minute)

Max. permissible continuous/intermittent pressure drop for the actual shaft version can be found on page 20.

Note: Intermittent pressure drop and oil flow must not occur simultaneously.

Function Diagrams

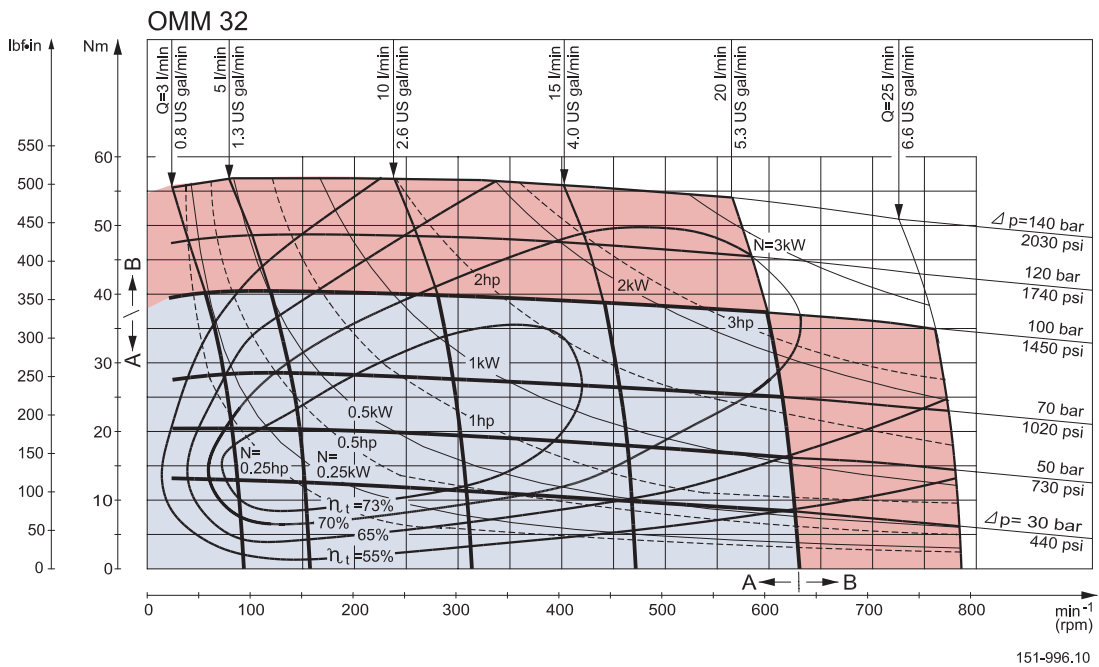
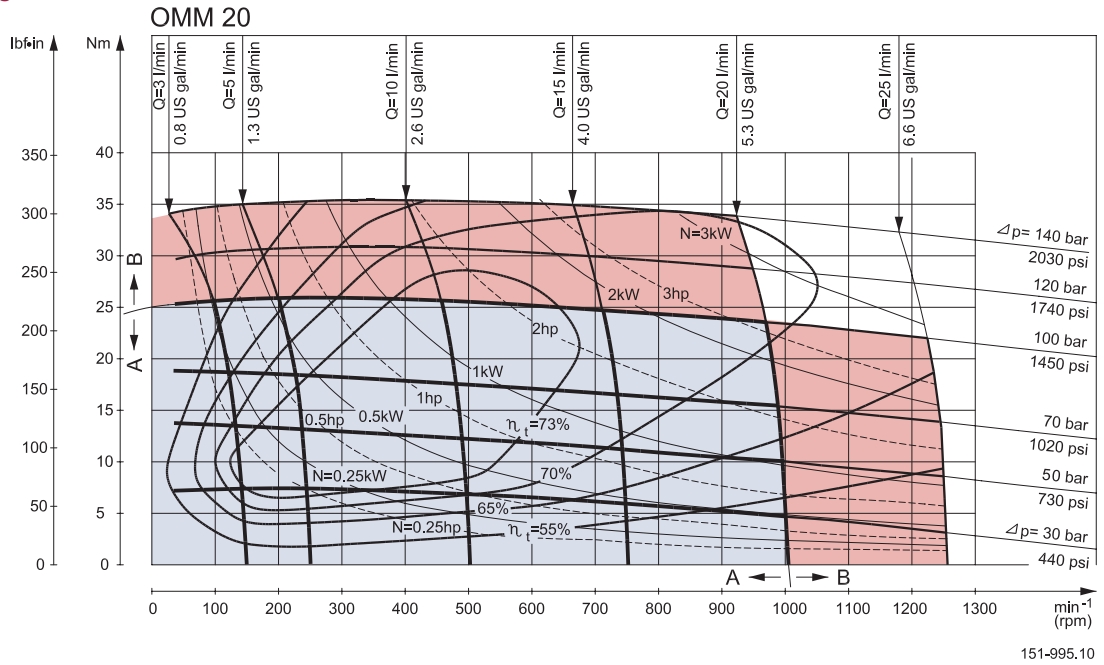

Explanation of function diagram use, basis and conditions can be found on page 4.

- A: Continuous range
- B: Intermittent range (max. 10% operation every minute)

Max. permissible continuous/intermittent pressure drop for the actual shaft version can be found on page 20.

Note: Intermittent pressure drop and oil flow must not occur simultaneously.



Function Diagrams

OMM 40

No function diagram available for OMM 40.

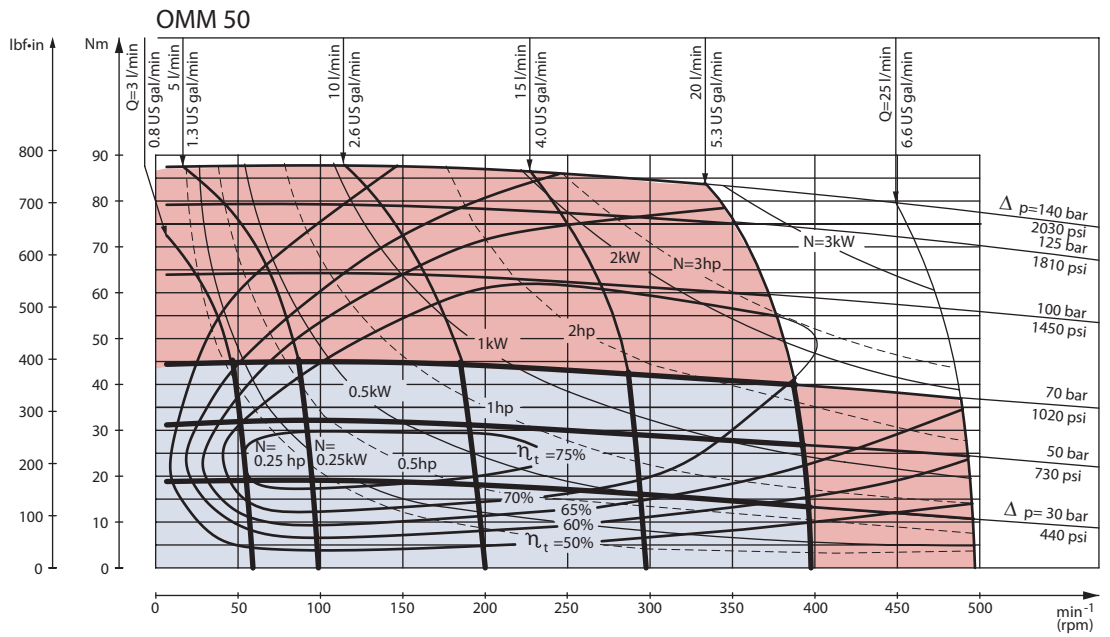

151-1660.11

Explanation of function diagram use, basis and conditions can be found on page 4.

- A: Continuous range
- B: Intermittent range (max. 10% operation every minute)

Max. permissible continuous/intermittent pressure drop for the actual shaft version can be found on page 20.

Note: Intermittent pressure drop and oil flow must not occur simultaneously.

**Shaft Version**

- A: Cylindrical shaft  
16 mm (xx in)
- D: Parallel key  
A5 • 5 • 16  
DIN 6885

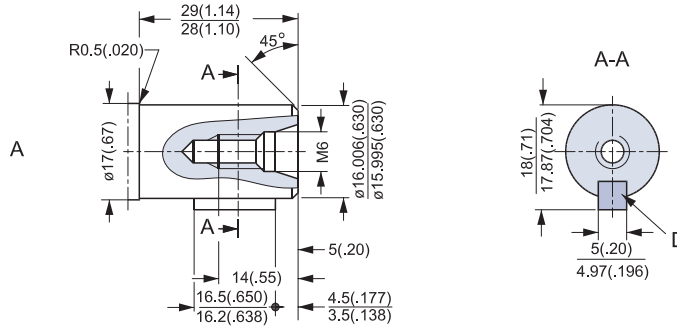

**US version**

- B: Cylindrical shaft  
 $\frac{5}{8}$  in
- E: Parallel key  
 $\frac{3}{16} \cdot \frac{3}{16} \cdot \frac{3}{4}$  in  
B.S. 46

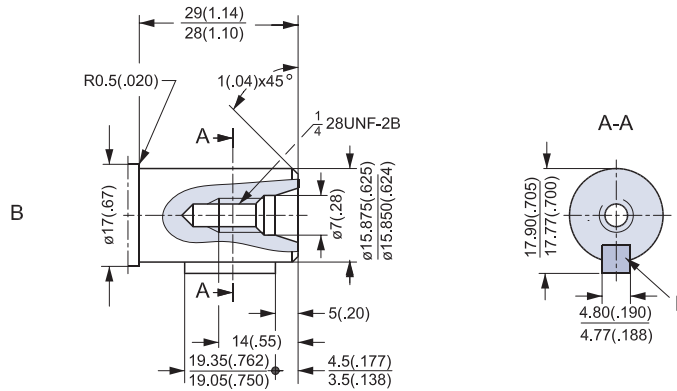

- C: Involute splined shaft  
B17 • 14, DIN 5482  
Measurement  $19,641 \pm 0.04$  mm  
over 3 mm pins deviates from  
DIN 5482

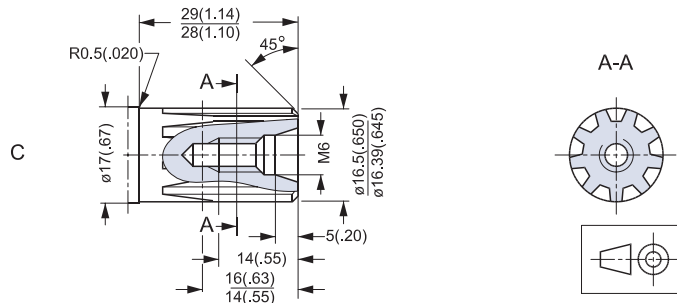

151-1866.10

**Port Thread Versions**

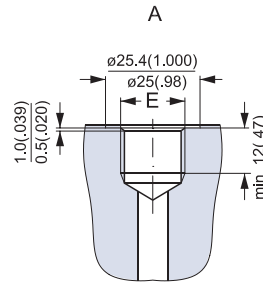

A: G main ports  
E: ISO 228/1 - G<sup>3</sup>/<sub>8</sub>

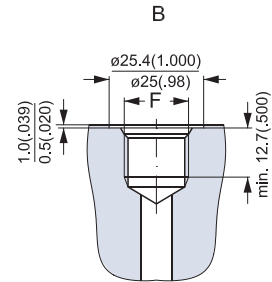

B: UNF main ports  
F: <sup>9</sup>/<sub>16</sub> - 18 UNF  
O-ring boss port

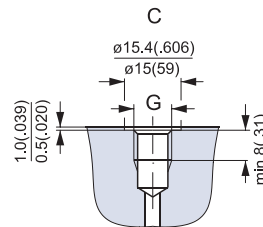

C: G drain ports  
G: ISO 228/1 - G<sup>1</sup>/<sub>8</sub>

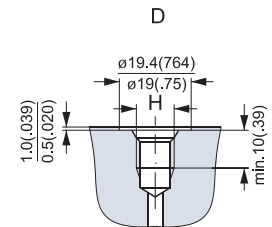

D: UNF drain ports  
H: <sup>3</sup>/<sub>8</sub> - 24 UNF  
O-ring port

151-1869.10

**Dimensions**

OMM  
 End port version.

Type	Length		Weight kg [lb]
	L <sub>max.</sub>	L <sub>1</sub> mm [in]	
OMM 8	104.0 [4.09]	3.5 [0.14]	1.9 [4.2]
OMM 12.5	106.0 [4.17]	5.5 [0.22]	2.0 [4.4]
OMM 20	109.0 [4.29]	8.5 [0.33]	2.1 [4.6]
OMM 32	114.0 [4.49]	13.5 [0.53]	2.2 [4.8]
OMM 40	118.0 [4.65]	17.0 [0.67]	2.3 [5.1]
OMM 50	122.0 [4.80]	21.5 [0.85]	2.4 [5.3]

C: M6; 10 mm [0.39 in] deep  
 D: G 3/8; 12 mm [0.47 in] deep  
 E: Drain connection G 1/8;  
 8 mm [0.39 in] deep

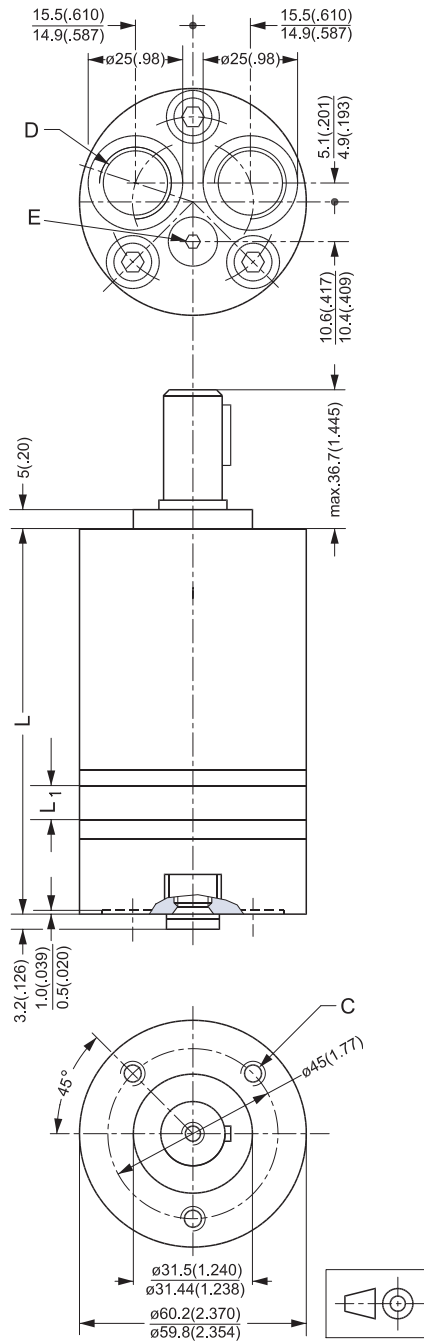

P301 008

**Dimensions**

OMM  
 End port version.

Type	Length		Weight kg [lb]
	L <sub>max.</sub>	L <sub>1</sub> mm [in]	
OMM 8	104.0 [4.09]	3.5 [0.14]	1.9 [4.2]
OMM 12.5	106.0 [4.17]	5.5 [0.22]	2.0 [4.4]
OMM 20	109.0 [4.29]	8.5 [0.33]	2.1 [4.6]
OMM 32	114.0 [4.49]	13.5 [0.53]	2.2 [4.8]
OMM 50	122.0 [4.80]	21.5 [0.85]	2.4 [5.3]

- C: 1/4 - 28 UNF - 2B;  
 min. 10 mm [0.39 in] deep
- D: 9/16 - 18 UNF;  
 12 mm [0.47 in] deep  
 O-ring boss port
- E: 3/8 - 24 UNF;  
 8 mm [0.39 in] deep  
 O-ring port

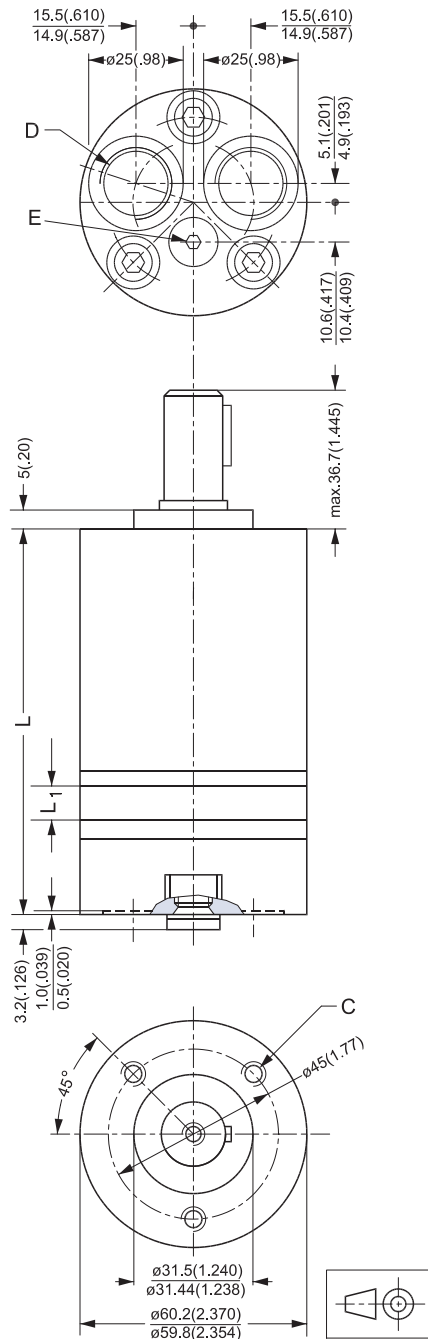

P301 008

**Dimensions**

OMM  
 Side port version.

Type	Length		Weight kg [lb]
	L <sub>max.</sub>	L <sub>1</sub> mm [in]	
OMM 8	104.0 [4.09]	3.5 [0.14]	1.9 [4.2]
OMM 12.5	106.0 [4.17]	5.5 [0.22]	2.0 [4.4]
OMM 20	109.0 [4.29]	8.5 [0.33]	2.1 [4.6]
OMM 32	114.0 [4.49]	13.5 [0.53]	2.2 [4.8]
OMM 40	118.0 [4.65]	17.0 [0.67]	2.3 [5.1]
OMM 50	122.0 [4.80]	21.5 [0.85]	2.4 [5.3]

C: M6; 10 mm [0.39 in] deep  
 D: G 3/8; 12 mm [0.47 in] deep  
 E: Drain connection G 1/8;  
 8 mm [0.39 in] deep

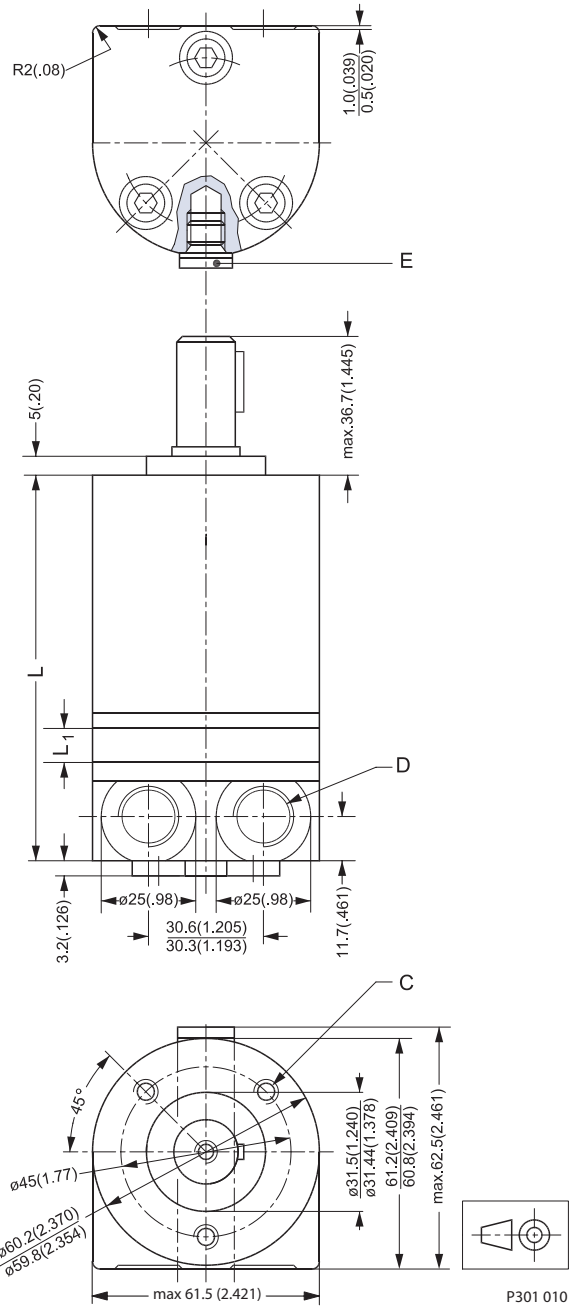

**Dimensions**

OMM  
 Side port version.

Type	Length		Weight kg [lb]
	L <sub>max.</sub>	L <sub>1</sub> mm [in]	
OMM 8	104.0 [4.09]	3.5 [0.14]	1.9 [4.2]
OMM 12.5	106.0 [4.17]	5.5 [0.22]	2.0 [4.4]
OMM 20	109.0 [4.29]	8.5 [0.33]	2.1 [4.6]
OMM 32	114.0 [4.49]	13.5 [0.53]	2.2 [4.8]
OMM 50	122.0 [4.80]	21.5 [0.85]	2.4 [5.3]

- C: 1/4 - 28 UNF - 2B;  
 min. 10 mm [0.39 in] deep
- D: 3/16 - 18 UNF;  
 12 mm [0.47 in] deep
- E: 3/8 - 24 UNF;  
 8 mm [0.39 in] deep

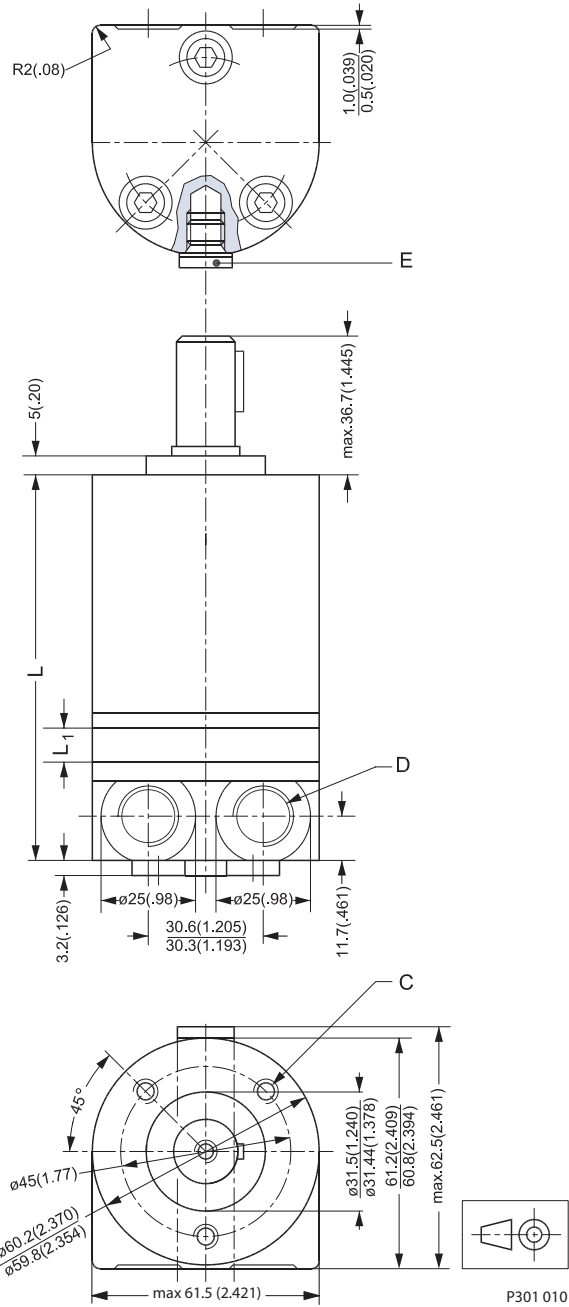

**2 Bolt Flange Kit, Code  
No. 151G0211**

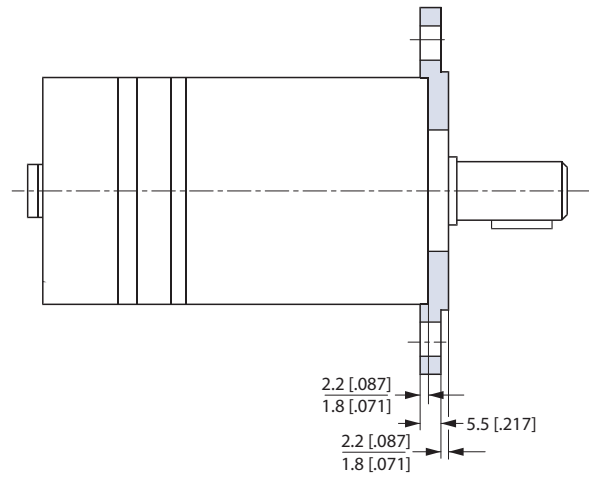
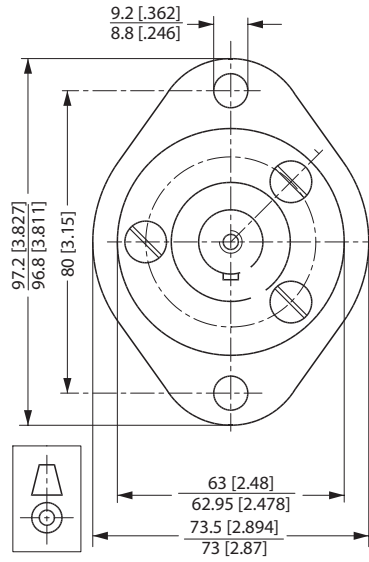

P301 013





OML and OMM  
Technical Information  
Notes

Notes



OML and OMM  
Technical Information  
Notes

Notes

### Installation of the Sauer-Danfoss Orbital Motors

#### *About the design*

- To ensure efficient operation all hydraulic components must be installed according to their individual instructions.
- The pump line must include a manometer connection.
- To ensure designed contact and minimise the tension all mounting flanges must be flate.

Hydraulic lines must be fitted correctly to prevent air entrapment.

#### *About the assembly*

- Follow the mounting instructions printed on the inside of the cardboard box.
- To prevent contamination, do not dismantle the plastic plugs from the connection ports until the fittings are ready to be assembled.
- Check that there is full face contact between the motor mounting flange and the mating part.
- Do not force the motor into place when tightening the mounting screws.
- Avoid unsuitable sealing material on fittings such as pack twine, teflon and others. Use only bonded seals, O-rings, steel washers and the like.
- When tightening the fittings never use a torque higher than the max. tightening torque stated in the instructions.
- Make sure that the cleanliness of the oil used is better than 20/16 (ISO 4406). Always use a filter for oil refilling.

### Starting Up and Running in the Hydraulic System

- Through a small-meshed filter fill up the tank with oil to the upper oil level mark .
- Start the drive engine, and if possible, let it work at its lowest speed. If the motor is provided with bleed screws, keep these open until the emerging oil is non-foaming.
- Check that all components are correctly connected (pump following the right direction of rotation etc.).
- In load-sensing systems, also make sure that the signal lines are bled.
- Indications of air in the hydraulic system:
  - oam in the tank
  - jerky movements of motor and cylinder
  - noise
- If so required, refill with oil.
- Connect the system to a separate tank that includes a filter (fineness max. 10 µm) with twice the capacity of the max. oil flow. Let the entire system run without load (no pressure) for about 30 minutes.
- Do not load the system until it is all bled and clean.
- Check the tightness of the system and make sure that its performance is satisfactory.
- Change the oil filter, and if so required, refill with oil.

### Operation

- Do not expose the motor to pressures, pressure drops and speeds above the max. values stated in the catalogue.
- Filter the oil to ensure that the contamination level 20/16 (ISO 4406) or better.

### Maintenance

- When working with hydraulic systems, the main criteria of operating safety and endurance is careful maintenance
- Always renew and replace oil, oil filters and air filters according to the instructions given by the respective manufacturers
- Regularly check the condition of the oil
- Frequently check system tightness and oil level



**Products we offer:**

- Bent Axis Motors
- Closed Circuit Axial Piston Pumps and Motors
- Displays
- Electrohydraulic Power Steering
- Electrohydraulics
- Hydraulic Power Steering
- Integrated Systems
- Joysticks and Control Handles
- Microcontrollers and Software
- Open Circuit Axial Piston Pumps
- Orbital Motors
- PLUS+1™ GUIDE
- Proportional Valves
- Sensors
- Steering
- Transit Mixer Drives

**Members of the Sauer-Danfoss Group:**

**Comatrol**

[www.comatrol.com](http://www.comatrol.com)

**Schwarz Müller-Inverter**

[www.schwarzmueller-inverter.com](http://www.schwarzmueller-inverter.com)

**Turolla**

[www.turollaocg.com](http://www.turollaocg.com)

**Hydro-Gear**

[www.hydro-gear.com](http://www.hydro-gear.com)

**Sauer-Danfoss-Daikin**

[www.sauer-danfoss-daikin.com](http://www.sauer-danfoss-daikin.com)

**Sauer-Danfoss** is a global manufacturer and supplier of high-quality hydraulic and electronic components. We specialize in providing state-of-the-art technology and solutions that excel in the harsh operating conditions of the mobile off-highway market. Building on our extensive applications expertise, we work closely with our customers to ensure exceptional performance for a broad range of off-highway vehicles.

We help OEMs around the world speed up system development, reduce costs and bring vehicles to market faster.

Sauer-Danfoss – Your Strongest Partner in Mobile Hydraulics.

**Go to [www.sauer-danfoss.com](http://www.sauer-danfoss.com) for further product information.**

Wherever off-highway vehicles are at work, so is Sauer-Danfoss.

We offer expert worldwide support for our customers, ensuring the best possible solutions for outstanding performance. And with an extensive network of Global Service Partners, we also provide comprehensive global service for all of our components.

Please contact the Sauer-Danfoss representative nearest you.

Local address:

Sauer-Danfoss (US) Company  
2800 East 13th Street  
Ames, IA 50010, USA  
Phone: +1 515 239 6000  
Fax: +1 515 239 6618

Sauer-Danfoss ApS  
DK-6430 Nordborg, Denmark  
Phone: +45 7488 4444  
Fax: +45 7488 4400

Sauer-Danfoss GmbH & Co. OHG  
Postfach 2460, D-24531 Neumünster  
Krokamp 35, D-24539 Neumünster, Germany  
Phone: +49 4321 871 0  
Fax: +49 4321 871 122

Sauer-Danfoss-Daikin LTD.  
Shin-Osaka TERASAKI 3rd Bldg. 6F  
1-5-28 Nishimiyahara, Yodogawa-ku  
Osaka 532-0004, Japan  
Phone: +81 6 6395 6066  
Fax: +81 6 6395 8585