

Technical
Information

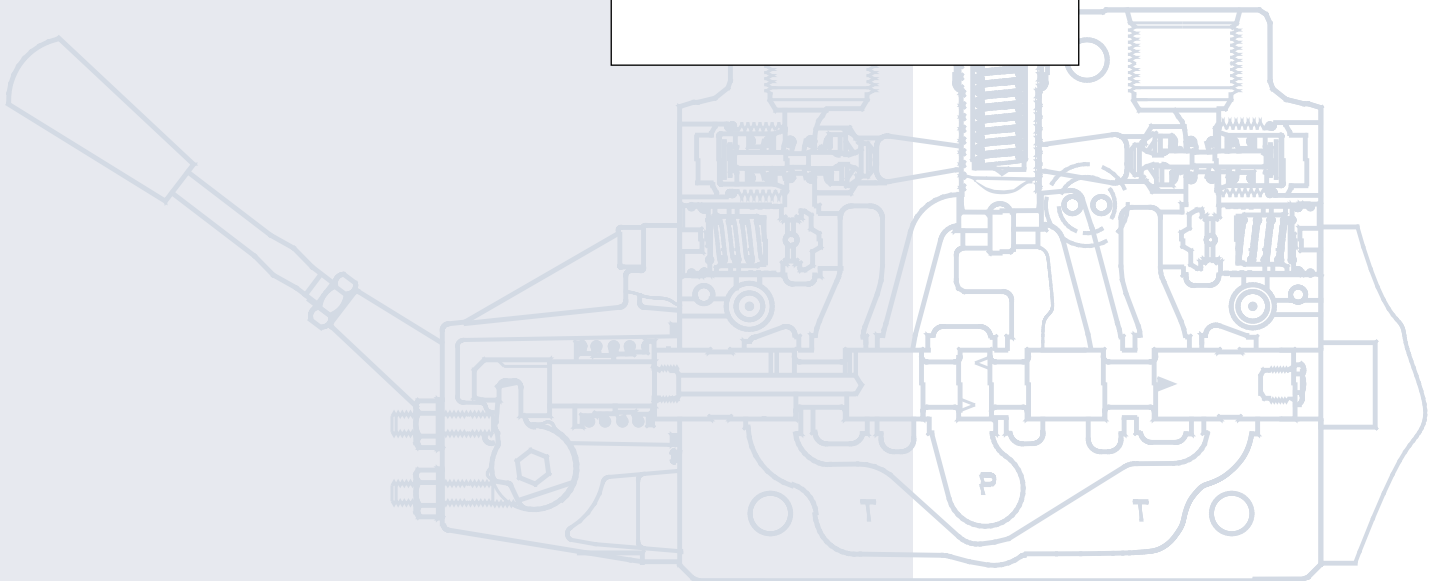

Revision History

Date	Page	Changed	Rev
Feb 2007	All	Major edition	BA
Oct 2009	All	Major edition	CA
Nov 2009	36-37	Tabel lines moved	CB
Nov 2009	16	Line added in table	CC
Jan 2010	14, 17, 41	Parts numbers changed	CD
Dec 2010	44	New back cover	CF
Sep 2011	39-42	New 4 pages: Safety in application section	DA

© 2011 Sauer-Danfoss. All rights reserved.

Sauer-Danfoss accepts no responsibility for possible errors in catalogs, brochures and other printed material. Sauer-Danfoss reserves the right to alter its products without prior notice. This also applies to products already ordered provided that such alterations can be made without affecting agreed specifications. All trademarks in this material are properties of their respective owners. Sauer-Danfoss, the Sauer-Danfoss logotype, the Sauer-Danfoss S-icon, PLUS+1™, What really matters is inside® and Know-How in Motion™ are trademarks of the Sauer-Danfoss Group.

Front cover illustrations: PA270004, F301102, F301196, F301197
 Drawing: 157-691

General	General Acronyms.....	5
	Valve system	6
	General features PVG 100	6
	PVP - Pump side module	6
	PVB – basic module.....	6
	Actuation modules.....	6
Function PVG 100	PVG 100 valve group with open center PVP	7
	PVG 100 valve group with closed center PVP	7
	PVG 100 Sectional Drawing PVP with Open Center	8
	PVG 100 sectional drawing with integrated priority valve.....	9
	Technical Data	11
	PVH, hydraulic actuation.....	11
	PVM, mechanical actuation	12
	PVE, reaction time	12
	PVE, oil consumption and hysteresis.....	13
	PVEO.....	13
	PVEA, PVEH and PVES	13
Technical Data	PVP 100 inlet modules.....	14
	PVP 100 accessories for open center pump side modules.....	14
	PVP (Open and Closed) Accessories bar pump side modules.....	15
	PVPV (Closed Center) Inlet modules.....	15
	PVPVP Closed Center Priority Modules	16
	PVB 100 basic modules	16
Modules and Code Numbers	Code number for use on PVG 100.....	17
	PVM, mechanical actuation.....	17
	PVMD, cover for mechanical actuation.....	17
	PVH, hydraulic actuation.....	17
	PVMR friction detent	17
	PVMF, mechanical float position	17
	PVE for PVG 100.....	18
	PVL A, suction valve (fitted in PVB).....	19
	PVL P, shock and suction valve (fitted in PVB)	19
	PVT 100 tank module	20
	PVTI 100/32 interface module.....	20
	Assembly kit PVG 100 / PVSI / PVT.....	20
	Assembly kit PVG 100 /PVTI interface module.....	20
	Assembly kit PVB 32.....	20

Technical Characteristics	General.....	21
	PVP, pump side module	21
	Open center flow rating.....	21
	Flow - US - Ls Margin of full Spool Shift.....	22
	PVB, Basic module.....	23
	PVLP, shock and suction valve	24
	PVLA, suction valve.....	24
Dimensions	Valve dimension, PVG 100, open center PVP	25
	Valve dimension, PVG100 / 32, closed center	26
	Valve dimension, PVG 100, closed center PVP with integrated priority valve.....	27
	General dimensions.....	28
	Valve dimension, PVG 100 with open end spool option.....	29
Hydraulic Systems	Hydraulic systems	30
	Sample specification (open end spool and standard section).....	31
Other Operating Conditions	Oil.....	32
	Mineral oil.....	32
	Non-flammable fluids.....	32
	Biodegradable oils.....	32
	Particle content, degree of contamination	32
	Filtration.....	33
	System filters	33
	Internal filters	33
Modules and Code Numbers	PVBS standard Spool Sub-assemblies	34
Safety in Application	Building in Safety	39
	FMEA (Failure Mode and Effect Analysis) IEC EN 61508.....	39
	Hazard and Risk Analysis ISO 12100-1 / 14121.....	39
	Control System Example.....	40
	PVG32 – Mainly used in system with fixed displacement pumps.....	42
	PVG100 – Alternative LS dump or pilot supply disconnect.....	42
	PVG120 – Pump disconnect/block for variable pumps	42
Module selection chart	Module selection chart	44
Order specification	Order specification	46

Acronyms

This table provides a definition of some commonly used terms

P = Proportional, V = Valve			
PVP	Pump Side Module (Inlet)	PVMD	Cover for Mechanical Activation
PVPF	Open Center PVP	PVMF	Cover for Mechanical Float
PVPV	Closed Center PVP	PVMR	Cover for Friction Detent
PVPVP	Closed Center PVP w/Priority	PVH	Cover for Hydraulic Actuation
PVPP	Electrical Pilot Shut-Off Valve	PVE	Electrical Actuator
PVPE	Electrical Unloading Valve	PVEA	Electrical Actuator-Fine Proportional
PVB	Basic Module (Body)	PVEH	Electrical Actuator-High Proportional
PVBZ	Basic Module (Body) Zero Leak	PVES	Electrical Actuator-Super Proportional
PVBS	Main Spool for PVB	PVEO	Electrical Actuator-ON / OFF
PVLP	Shock Valve	PVT	Tank Side Module
PVLA	Anti-Cavitation Valve	PVAS	Assembly (Tie Rod) Kit
PVM	Mechanical Actuator		

**Standard, Oil Flow
 Direction and Setting of
 max Flow**

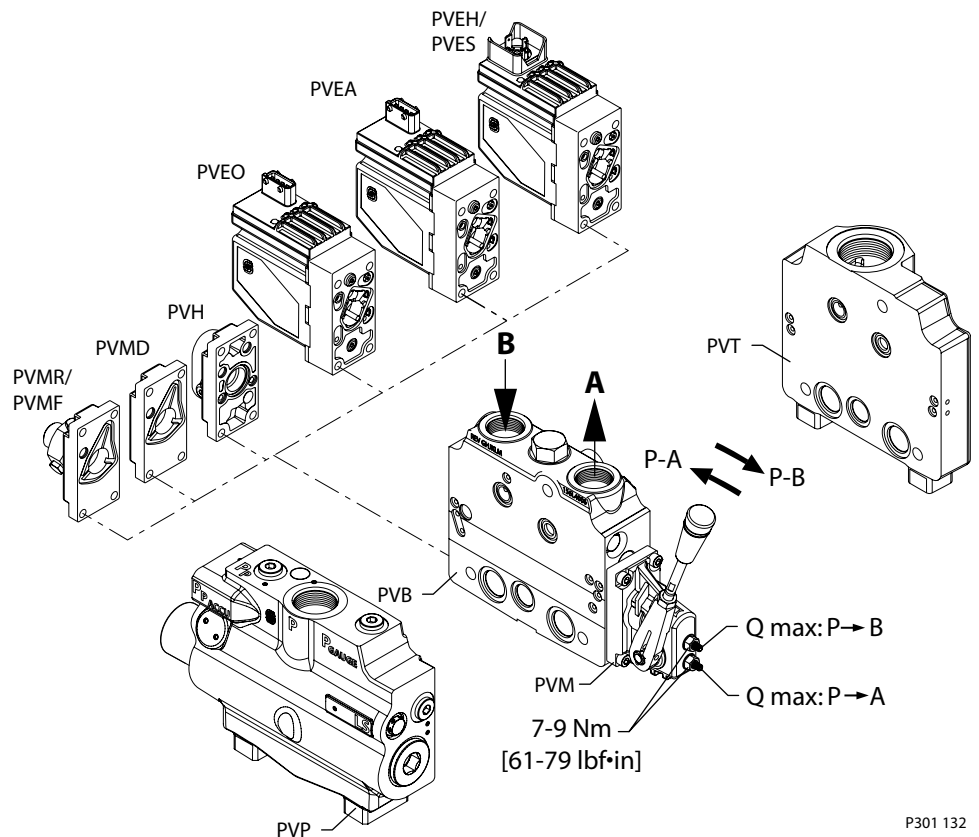

General

Valve system

PVG 100 is a hydraulic load sensing valve, designed to fulfill customer requirements. From a simple load sensing directional valve to an advanced electro hydraulic controlled load independent proportional valve.

The PVG 100 modular system makes it possible to build up a valve group to fulfill customer requirements. The compact external dimensions of the valve remains unchanged whatever combination is specified.

General features PVG 100

- Load independent flow control
 - Oil flow to an individual function is independent of the load on this function
 - Oil flow to one function is independent of the load pressure of other functions
- Anti – saturation (flow sharing)
 - In case of saturation, pump flow is shared between all functions, independent of load.
- Good regulation characteristics
- Up to 8 PVB 100 basic modules per valve group
- Up to 10 PVB 100/32 basic modules per valve group
- BSP and UNF connection threads

PVP - Pump side module

- Build in load sense relief valve
- System pressure up to 350 bar (5075 psi)
- Full Flow dump valve (open center only)
- Pilot supply shut off
- Versions
 - Open center version for systems with fixed displacement pumps
 - Closed center versions for systems with variable displacement pump
 - Integrated priority valve
- Integrated pilot supply valve
- Accumulator gauge connection
- Pressure gauge connection
- Pilot gauge connection

PVB – basic module

- Integrated pilot operated check valves in A and B work ports for low internal leakage
- Integrated pressure compensator
- Interchangeable spools
- Depending on requirements the basic module can be supplied with :
 - Shock/suction valves
 - Different spools

Actuation modules

The basic module is always fitted with mechanical actuator PVM, which can be combined with the following as required:

- Electrical actuator
 - PVES – super proportional
 - PVEH – proportional high
 - PVED – Can-bus interface
 - PVEA – proportional, fine
 - PVEO – ON/OFF
- PVH, cover for hydraulic actuation
- PVMD, for mechanical actuation
- PVMR, for friction detent*
- PVMF, for mechanical float*

* Not compatible with PO check modules

**PVG 100 Valve Group
with Open Center PVPF**

When the pump is started and the main spools in the individual basic modules are in the neutral position, oil flows from the pump, through connection P, across the pressure matching spool to tank. The oil flow led across the pressure matching spool determines the pump pressure (stand-by pressure).

When one or more of the main spools are actuated, the highest load pressure is fed through the shuttle valve circuit to the spring chamber behind the pressure matching spool, and completely or partially closes the connection to tank.

Pump pressure is applied to the opposite side of the pressure matching spool.

The pressure relief valve will open should the load pressure exceed the set value, diverting pump flow back to tank.

**PVG 100 Valve Group
with Closed Center PVPV**

In load sensing systems the load pressure is led to the pump regulator via the LS connection.

In the neutral position the pump control sets the displacement so that leakage in the system is compensated for, to maintain the set stand-by pressure (pump margin).

When a main spool is actuated the pump regulator will adjust the displacement so that the set differential pressure between P and LS is maintained.

The pressure relief valve in PVP should be set at a pressure of approx. 20 bar [290 psi] **below maximum system pressure** (set on the pump or external pressure relief valve).

PVG100 Basic Modules

In a pressure-compensated basic module the compensator maintains a constant pressure drop across the main spool – both when the load changes and when a module with a higher load pressure is actuated.

Besides independent flow the other advantage of post-compensated work sections is the ability to control multifunction operation when flow demand exceeds pump capacity. This means that all work sections will continue to function regardless of differences in their load and regardless of the pump flow. The flow relationships specified between functions will be maintained over the full flow range of the pump.

The shock valves PVLP with fixed setting and the suction valves PVLA on ports A and B are used for the protection of the individual working function against overload and/or cavitation.

With post-compensated valves, the rating of the A- and B work-port flow will depend on the pressure drop across the main spool PVBS. In open center systems, this pressure drop (standby-pressure) is generated by the volume of pump flow led to tank across the pressure adjusting spool in the inlet PVPF. Since the pressure drop varies with pump flow volume led to tank, also the A- and B work-port flow will vary (see further details page 21).

In closed center systems, the pressure drop across the main spool equals the standby setting of the pump, measured at the P-port of the valve. The A and B work port flow will remain unchanged as long as the standby is unchanged.

PVG 100
Sectional Drawing
PVP with Open Center

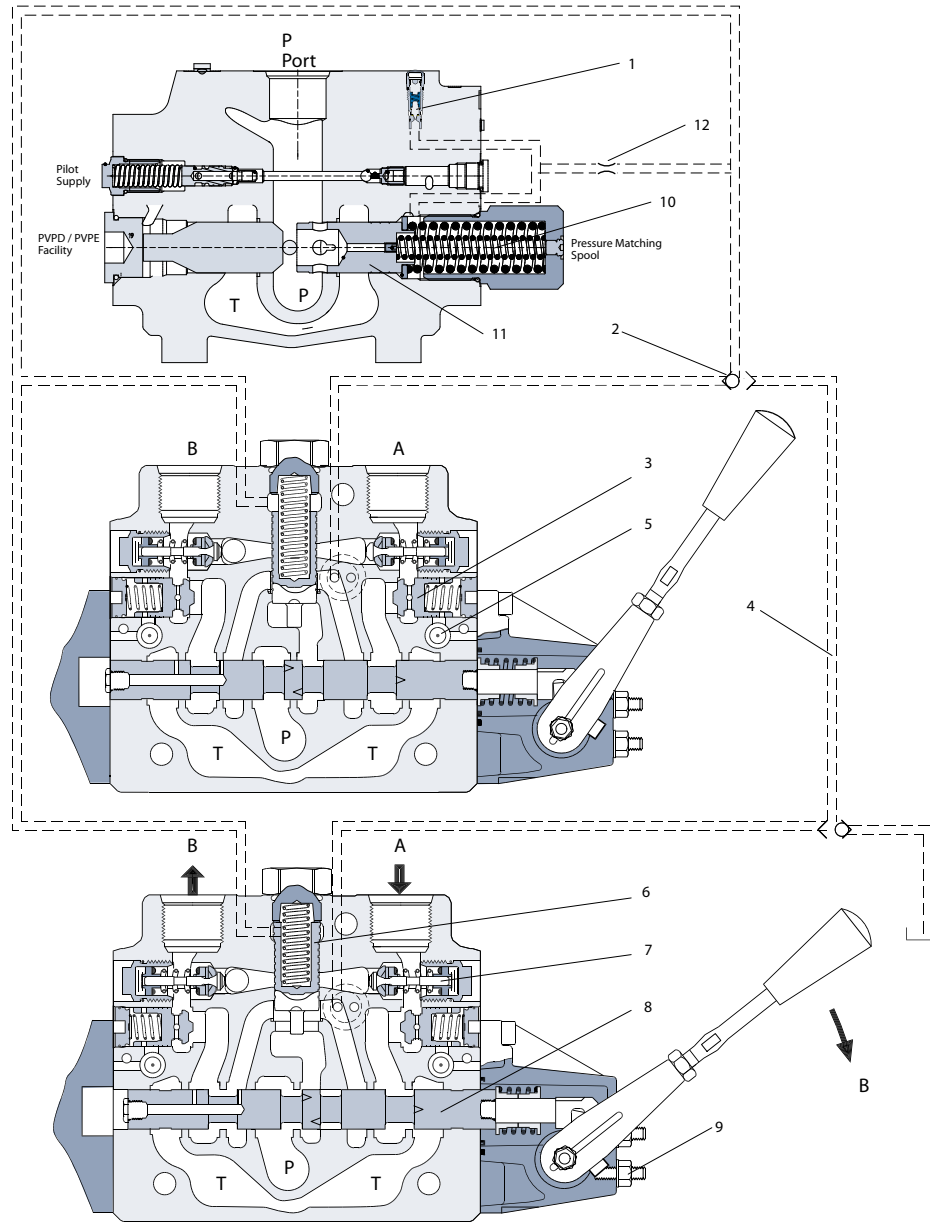

P301 234

- | | |
|------------------------------------|--|
| 1. LS relief valve | 6. Pressure compensator |
| 2. Shuttle valve | 7. Shock and suction valve, PVLP |
| 3. Pilot operated check valve, POC | 8. Main spool, PVBS |
| 4. LS line | 9. Max. oil flow adjustment screws for ports A and B |
| 5. Logic cartridge for POC | 10. Spring 12 or 20 bar |
| | 11. Pressure matching spool |
| | 12. Orifice |

PVG 100
Sectional Drawing
PVP with Integrated
Priority Valve

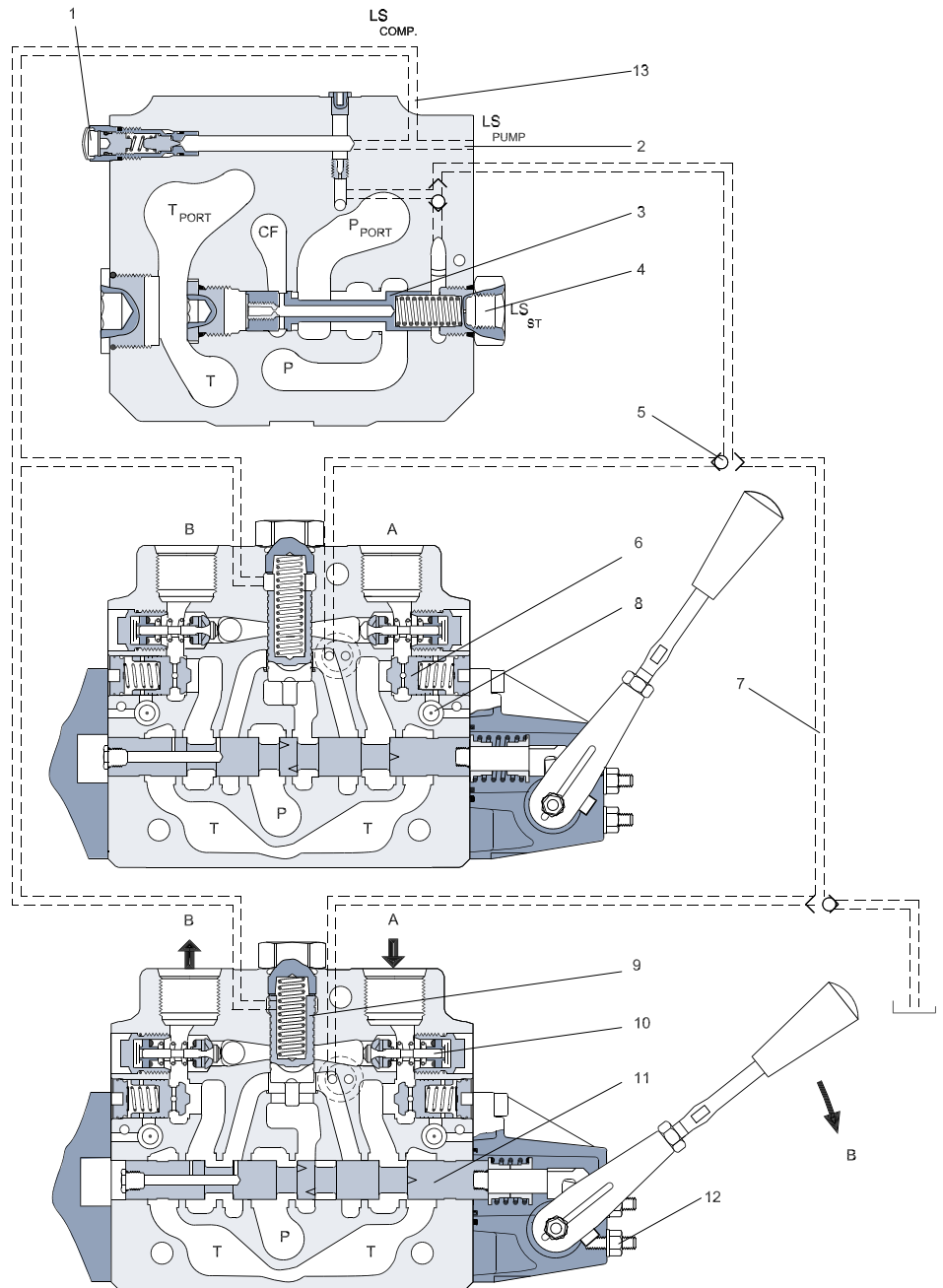

157-670.10 .10

- | | |
|------------------------------------|---|
| 1. LS relief valve | 8. Logic cartridge for POC |
| 2. LS connection | 9. Pressure compensator |
| 3. Priority spool for CF | 10. Shock and suction valve, PVLP |
| 4. LS connection for steering unit | 11. Main spool, PVBS |
| 5. Shuttle valve | 12. Max. oil flow adjustment screws for ports A and B |
| 6. Pilot operated check valve, POC | 13. LS comp (LS signal sent back to compensators) |
| 7. LS line | |



PVG 100 Proportional Valve
Technical Information
Notes

Notes

PVG 100
Valve Group

The technical data for PVG 100 are typical measured results. For the hydraulic system a mineral based hydraulic oil with a viscosity of 21 mm²/s [102 SUS] and a temperature of 50°C [122°F] was used.

Max. pressure	Port P continuous	350 bar	[5075 psi]
	Port A/B	350 bar	[5075 psi]
	Port T, static / dynamic	25 bar/40 bar	[365/580 psi]
	Port T0, static / dynamic	5 bar/10 bar	[75/145 psi]
Oil flow, rated (See characteristics,	Port P	250 l/min	[66 US gal/min]
	Port A/B, with press. comp.	180 l/min	[47.6 US gal/min]
Spool travel, standard		± 7 mm	[±0.28 in]
Spool travel, float position spool P→A→F	Proportional range	A: 5.5 mm, B: 7	[±0.22 in]
	Float position	8 mm	[±0.32 in]
Dead band, flow control spools	Standard	± 1.5 mm	[±0.06 in]
Max. spool leakage at 100 bar [1450 psi] and	A/B → T, without shock valve	20 cm ³ /min	[1.85 in ³ /min]
	A/B → T, with shock valve	25 cm ³ /min	[2.15 in ³ /min]
Max. internal leakage with pilot operated check valve at 200 bar [2900 psi] and	A/B → T, without shock valve	1 cm ³ /min	[0.06 in ³ /min]
	A/B → T, with shock valve	6 cm ³ /min	[0.37 in ³ /min]
Oil temperature (inlet temperature)	Recommended temperature	30 → 60°C	[86 → 140°F]
	Min. temperature	-30°C	[-22°F]
	Max. temperature	+90°C	[194°F]
Ambient temperature		-30 → +60°C	[-22 → +140°F]
Oil viscosity	Operating range	12 - 75 mm ² /s	[65 - 347 SUS]
	Min. viscosity	4 mm ² /s	[39 SUS]
	Max. viscosity	460 mm ² /s	[2128 SUS]
Filtration (See page 32-33)	Max. contamination (ISO 4406)	23/19/16	23/19/16

PVH,
Hydraulic Actuation

Regulation range	5-15 bar	[75-220 psi]
Max. pilot pressure	30 bar	[435 psi]
Max. pressure on port T 1)	10 bar	[145 psi]

¹⁾ The PVRHH remote control (hydraulic joystick) lever should be connected direct to tank.

**PVM,
 Mechanical Actuation**

Regulation range, control lever standard spool		Proportional range	±19.5°	
Regulation range, float		Proportional range Float position	±15.3° 22.3°	
Operating force			Neutral position	Max. spool travel
		PVM + PVMD	22 ± 3 N·m [5.0 ± 0.7 lbf·in]	28 ± 3 N·m [6.3 ± 0.7 lbf·in]
		PVM + PVE ¹⁾	22 ± 3 Nm [5.0 ± 0.7 lbf·in]	28 ± 3 Nm [6.3 ± 0.7 lbf·in]
		PVM + PVH	27 ± 3 Nm [6.0 ± 0.7 lbf·in]	83 ± 3 Nm [18.7 ± 0.7 lbf·in]
Operating force	PVM + PVMR	Spool displacement from neutral position		26 Nm [230 lbf·in]
		Spool displacement from any other position		16.5 Nm [146 lbf·in]
	PVM + PVMF	Spool displacement from neutral position		22 Nm [5.0 lbf·in]
		Spool displacement into float position		60 Nm [13.5 lbf·in]
		Spool displacement away from float position		28 Nm [6.3 lbf·in]
Control lever positions		No.	2 × 6	

¹⁾PVE without voltage applied

PVE, Reaction Time

Voltage	Function		PVEO	PVEA	PVEH	PVES
			ON/OFF	Prop.	Prop.	Prop.
			s	fine	high	super
			s	s	s	s
Neutral switch	Reaction time from neutral position to max. spool travel	Max.	0.235	0.500	0.230	0.230
		Rated	0.180	0.320	0.150	0.150
		Min.	0.120	0.250	0.120	0.120
Neutral switch	Reaction time from max. spool travel to neutral position	Max.	0.175	0.550	0.175	0.175
		Rated	0.090	0.400	0.090	0.090
		Min.	0.065	0.300	0.065	0.065
Constant voltage	Reaction time from neutral position to max. spool travel	Max.	–	0.500	0.200	0.200
		Rated	–	0.320	0.120	0.120
		Min.	–	0.250	0.050	0.050
Constant voltage	Reaction time from max. spool travel to neutral position	Max.	–	0.250	0.100	0.100
		Rated	–	0.200	0.090	0.090
		Min.	–	0.150	0.065	0.065
Hysteresis ¹⁾		rated	-	2%	4%	<1%

¹⁾ Hysteresis is indicated at rated voltage and f = 0.02 Hz for one cycle. A cycle incl. N > full A > N > full B > N.

**PVE,
 Oil Consumption**

Voltage	Function		PVEO ON/OFF	PVEA Prop. fine	PVEH Prop. high	PVES Prop. super
Without voltage	Pilot oil flow per PVE	Neutral	0 l/min [0 US gal/min]	0 l/min [0 US gal/min]	0 l/min [0 US gal/min]	0 l/min [0.106 US gal/min]

PVEO

		PVEO	
Supply voltage U_{DC}	rated	12 V DC	24 V DC
	range	11 V to 15 V	22 V to 30 V
	max. ripple	5%	
Current consumption at rated voltage		0.65 A @ 12 V	0.33 A @ 24 V
Input impedance in relation to $0.5 \cdot U_{DC}$		12 K Ω	
Power consumption		8 W	

PVEA, PVEH and PVES

		PVEA, PVEH and PVES	
Supply voltage U_{DC}	rated	11 V to 32 V	
	range	11 V to 32 V	
	max. ripple	5%	
Current consumption at rated voltage	PVEH/PVES (PVEA)	0.57 (0.28) A @ 12 V	0.3 (0.15) A @ 24 V
Signal voltage	neutral	$0.5 \cdot U_{DC}$	
	A-port \leftrightarrow B-port	$0.25 \cdot U_{DC}$ to $0.75 \cdot U_{DC}$	
Signal current at rated voltage		0.25 mA to 0.70 mA	
Input impedance in relation to $0.5 \cdot U_{DC}$		12 K Ω	
Input capacitor		100 nF	
Power consumption	PVEH/PVES (PVEA)	7 (3.5) W	

For detailed information, see PVE actuator catalog, 520L0553

PVPF (Open Center) Inlet Modules

Symbol	Description	"G1" BSP Port	1-5/16"-12 SAE Port
	Open center pump side module for pumps with fixed displacement. Max pump flow 250 lpm [66 gpm].	12 bar spring*	161B5110
	With pilot supply for PVE actuation. With pilot gauge port.	20 bar spring*	161B5112
	Open center pump side module for pumps with fixed displacement. Max pump flow 250 lpm [66 gpm].	12 bar spring*	11013065
	With pilot supply for PVH/PVHC actuation. With pilot gauge port.	20 bar spring*	11013067
	Open center pump side module for pumps with fixed displacement. Max pump flow 250 lpm [66 gpm].	12 bar spring*	161B5140
	With pilot supply for PVE actuation. Accumulator port and facility for pilot shut-off valve (PVPP).	20 bar spring*	161B5142
	Open center pump side module for pumps with fixed displacement. Max pump flow 250 lpm [66 gpm].	12 bar spring*	11013071
	With pilot supply for PVH/PVHC actuation. Accumulator port and facility for pilot shut-off valve (PVPP).	20 bar spring*	11013073

* Spring for pressure matching spool - PVPF only. Refer to page 21 for further details.

PVPF Accessories for Pump Side Modules

Symbol	Description	Code Number
	Dummy Spool	155G5041
	PVPE Electrically actuated normally open, unloading valve.	12 V
	If PVPE is not required the "Dummy Spool" must be specified	24 V

PVP (Open and Closed) Accessories for Pump Side Modules

Symbol	Description	Code Number
	PVPP Electrically Actuated Pilot Shut Off Valve Normal Closed Solenoid Valve	12 V 800572719
		24 V 800572819

PVPV (Closed Center) Inlet Modules

Symbol	Description	"G1" BSP port	1-5/16"-12 SAE Port
	Closed Center Pump Side Module for pumps with variable displacement. Max pump flow 250 lpm [66 gmp]. With pilot supply for PVE actuation. With pilot gauge port.	161B5111	161B5511
	Closed Center Pump Side Module for pumps with variable displacement. Max pump flow 250 lpm [66 gmp]. With pilot supply for PVH/PVHC actuation. With pilot gauge port.	11013069	11013070
	Closed Center Pump Side Module for pumps with variable displacement. Max pump flow 250 lpm [66 gmp]. With pilot supply for PVE actuation. With pilot gauge port. Accumulator port and facility for pilot shut off valve.	161B5141	161B5541
	Closed Center Pump Side Module for pumps with variable displacement. Max pump flow 250 lpm [66 gmp]. With pilot supply for PVH/PVHC actuation. With pilot gauge port. Accumulator port and facility for pilot shut off valve.	11013075	11013076

PVPVP Closed Center Priority Modules

Symbol	Description	BSP P: G 3/4 T: G1 CF: G 1/2	SAE P: 1-1/16-12 T: 1-5/16-12 CF: G 3/4-16
	PVPVP Closed Center Pump Side Modules for pumps with variable displacement. Max pump flow 200 lpm [52.8 gpm] With integrated priority function. With pilot supply for PVE actuation,	161B5211	161B5611
	PVPVP Closed Center Pump Side Modules for pumps with variable displacement. Max pump flow 200 lpm [52.8 gpm] With integrated priority function. With pilot supply for PVH/PVHC actuation,	11013077	11013078

PVB 100 Basic Modules: For use with standard Spools

Symbol	Description	Code Number		
		BSP G 3/4	SAE 1 1/16-12	
	PVB Post Compensated	Without PVLP	161B6250	161B6650
		With PVLP	161B6260	161B6660
	PVBZ Post Compensated	Without PVLP	161B6252**	161B6652**
	With pilot Operated check valve on work Port A and B	With PVLP	161B6262**	161B6662**
	PVB Endmodule Post Compensated	With PVLP	11006889	-
	PVB with tank port in bottom of PVB Post Compensated	With PVLP	11006887*	-

* To be used with PVB endmodules

** Not compatible with PVMR or PVMF Spools

PVB 100 Basic Modules: For use with exposed Spools - Seal plate on "A" port side included

Symbol	Description	Code Number	
		BSP G 3/4	SAE 1 1/16-12
	Without PVLP	11051707	11051708
	With PVLP	11051709	11051710
	Without PVLP	11051711*	11051712*
	With pilot Operated check valve on work Port A and B	11051713*	11051714*

* Not compatible with PVMR or PVMF Spools

Code Numbers for Use on PVG 100 157B....

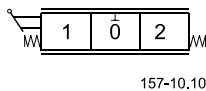

157-10.10

PVM Mechanical actuation	Code number	
	w. stop screws*	w/o stop screws
PVM, Aluminum Housing Standard, spring centered	157B3171	157B3191
PVM, Aluminum Housing Without Actuation Lever and base. Shaft for mounting of actuation lever.	157B3173	157B3193
PVM, Cast Iron Housing Standard, Spring Centered	157B3161	-
PVM, Anodized Aluminum Housing Standard Spring Centered	157B3184	-

* Stop screw provide Individual flow adjustment on ports A and B.

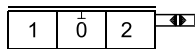

157-199.10

PVMD* Cover for purely mechanical actuation	Code number
PVMD Cover - Aluminum	157B0001
PVMD Cover - Cast Iron	157B0021

* Opposite of PVM, not compatible with PVG 100 PVBZ

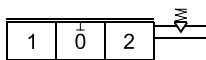

157-210.10

PVH Cover for hydraulic remote control	Code number
PVH	G 1/4 157B0008
	9/16-18 UNF 157B0007

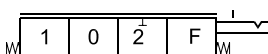

157-208.10

PVMR * Cover for friction detent	Code number
PVMR* Cover for friction detent	157B0015

* Opposite of PVM, not compatible with PVG 100 PVBZ

PVMF* Mechanical float detent	Code number
PVMF* Mechanical float position lock, P -> A -> F	157B0005

* Opposite of PVM, not compatible with PVG 100 PVBZ
 520L0720 • Rev DA • Sep 2011

**Code Numbers for
 Use on PVG 100
 157B....**

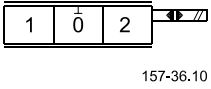

PVE for PVG 100

PVEO, ON/OFF actuation Code no. 157B....		Hirschmann		AMP		Deutsch	
		12 V	24 V	12 V	24 V	12 V	24 V
PVEO	ON/OFF	4216	4228	4901	4902	4291	4292
	ON/OFF with ramp	4217	4229	4903	4904	-	-
	ON/OFF anodized	4266	4268	-	4272	-	-

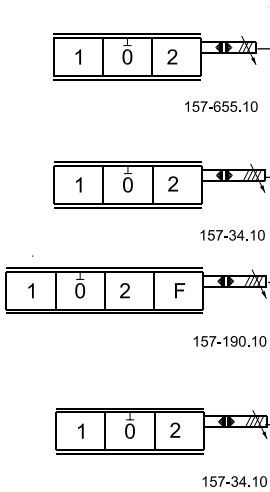

PVEA/PVEH/PVES, proportional actuation Code no. 157B....		Hirschmann	AMP	Deutsch
		11 - 32 V	11 - 32 V	11 - 32 V
PVEA	Standard, active fault monitoring	-	4734	4792
	Standard, passive fault monitoring	-	4735	-
PVEA-DI	Standard, active fault monitoring	-	4736	4796
	Standard, passive fault monitoring	-	4737	-
PVEH	Standard, active fault monitoring	4032	4034	4092
	Standard, passive fault monitoring	4033	4035	4093
	Float, passive fault monitoring	-	-	4392
	Standard, passive, anodized	-	4073	-
PVEH-DI	Float, active fault monitoring	4332	4034	-
	Standard, active fault monitoring	-	4036	4096
	Standard, passive fault monitoring	-	4037	-
PVES	0% hysteresis, active fault monitoring	4832	4834	4892
	0% hysteresis, passive fault monitoring	4833	4835	-
PVEP	PVEP, voltage PWM, active fault monitoring	-	-	4752
PVED	Can-bus interface	-	4943	4944

PVLA Anti-Cavitation Valve Fitted into PVB

Symbol	Description	Code number
<p>P301 134</p>	<p>PVLA</p> <p>Anti-cavitation valve installed in PVLP cavity of PVB</p>	157B2001
<p>P301 135</p>	<p>Cap</p> <p>For connecting non-active work port to tank</p>	157B2002

PVLP

Shock / Anti-Cavitation valve fitted into PVB

Symbol	Description	Setting		Code number
		bar	psi	

PVT 100 Tank Module

Symbol	Description	Port size	Code number
	PVT Without active elements With T-port PVLP shock valve facility	G 1 ¹ / ₄	161B2500
	PVT Without active elements With T-port PVLP shock valve facility	1 ⁵ / ₈ -UN	161B2520
	PVT Without active elements With T-port PVLP shock valve facility With LX connection G 1 ¹ / ₄ [9/16 in – 18 UNF	G 1 ¹ / ₄	161B2505
	PVT Without active elements With T-port PVLP shock valve facility With LX connection G 1 ¹ / ₄ [9/16 in – 18 UNF	1 ⁵ / ₈ -UN	161B2525

PVTI 100/32 Interface Module*

Symbol	Description	Portsize	Code number
	PVTI Without active elements With T-port PVLP shock valve facility	G 1 ¹ / ₄	161B2200
	PVTI Without active elements With T-port PVLP shock valve facility	1 ⁵ / ₈ -UN	161B2220

* Must use T0 equipped PVG32 Modules - See Sauer-Danfoss Technical Information Basis Modules PVBZ - 520L0721 for details

Assembly Kit PVG 100 PVSI / PVT

Description	Code number 161B....							
	1 PVB	2 PVB	3 PVB	4 PVB	5 PVB	6 PVB	7 PVB	8 PVB
Tie bolts and seals	8001	8002	8003	8004	8005	8006	8007	8008

Assembly Kit PVG 100 / PVTI Interface Module

Description	Code number 161B....							
	1 PVB	2 PVB	3 PVB	4 PVB	5 PVB	6 PVB	7 PVB	8 PVB
Tie bolts and seals	8021	8022	8023	8024	8025	8026	8027	8028

Assembly Kit PVB 32

General

The characteristics in this catalog are typical measured results. During measuring a mineral based hydraulic oil with a viscosity of 21 mm²/s [102 SUS] at a temperature of 50°C [122°F] was used.

**PVPF only
 Pump Side Module**

Pressure relief valve characteristic in PVP

The pressure relief valve is set at an oil flow of 15 l/min [4.0 US gal/min].

Setting range:
 30 to 350 bar [435 to 5075 psi]

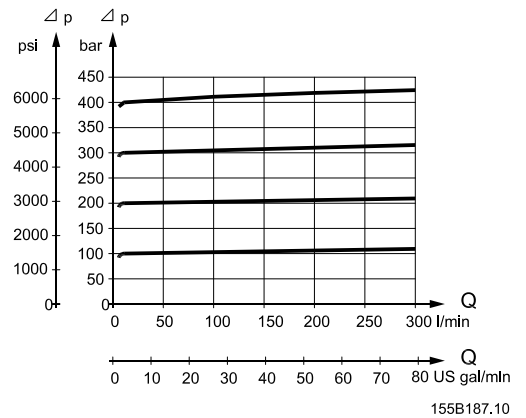

**Neutral flow pressure in PVP,
 open center**

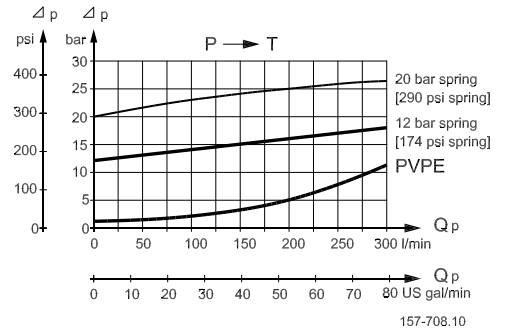

Open Center Flow Rating

As mentioned on page 7, the flow rating of the different main spools will depend on the standby pressure available. In open center systems, the standby pressure equals the pressure drop P->T, see above diagram. A pump flow of 150 l/min led to tank across the pressure adjusting spool, will generate a standby pressure of app. 15 bar (PVP with 12 bar spring). The according main spool flow ratings will correspond to the curves on page 23.

For PVPs with a 20 bar spring, the standby pressure available will be 20 bar or higher. Hence the according main spool flow ratings will correspond to page 23.

Closed Center Flow Rating: Ls Pumps

The flow rating of a the different main spools, PVBS, is dependent upon the Load Sense margin (pump margin pressure). The nominal flows specified for each PVBS is specified at 15 bar [218 psi] Ls margin pressure. If Ls margin is increased above 15 bar [218 psi], the PVBS will deliver more flow then the nominal rating. The following curves show the relationship between Ls margin and work port flow.

Because of flow forces and cylinder differential areas Sauer-Danfoss recommends caution when specifying Ls margins over 25 bar [360 psi].

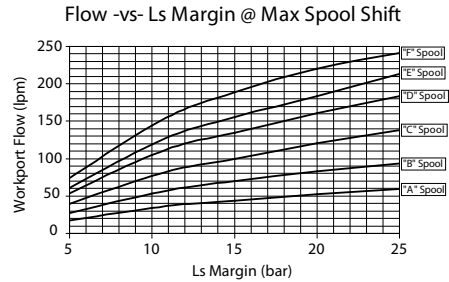

P301 233

Closed Center Flow Rating: Pressure Compensated Pumps

As noted above, work port flow is dependent upon the Ls margin set on the pump. PC pumps maintain a constant discharge pressure which is equal to the PC setting on the pump. Hence the Ls margin for PC pumps can be thought of as the difference between the PC setting and the load pressure. Therefore work port flow will change with load pressure, thus, pressure compensated flow will not be obtained.

PVB, Basic Module

Pressure drop PVB at max. main spool travel

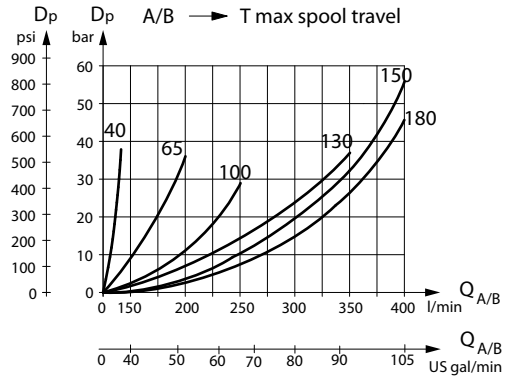

V310203.A

Pressure drop PVB for open spool in neutral position

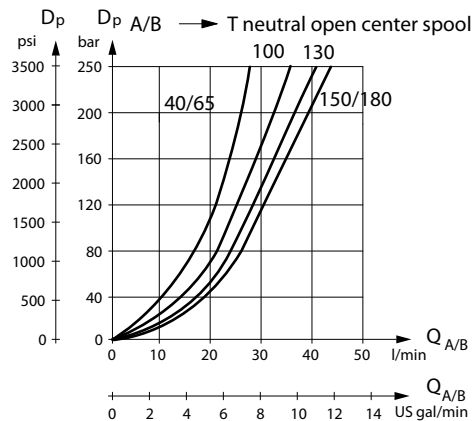

V310204.A

**PVB,
 Basic Module**

**PVB with pressure compensation, closed center PVP
 Oil flow as a function of spool travel for spools A to F**

Set pressure difference between pump pressure and LS signal = 15 bar [218 psi]
 measured at the P-port of the valve. For spool size reference [see page 22](#).

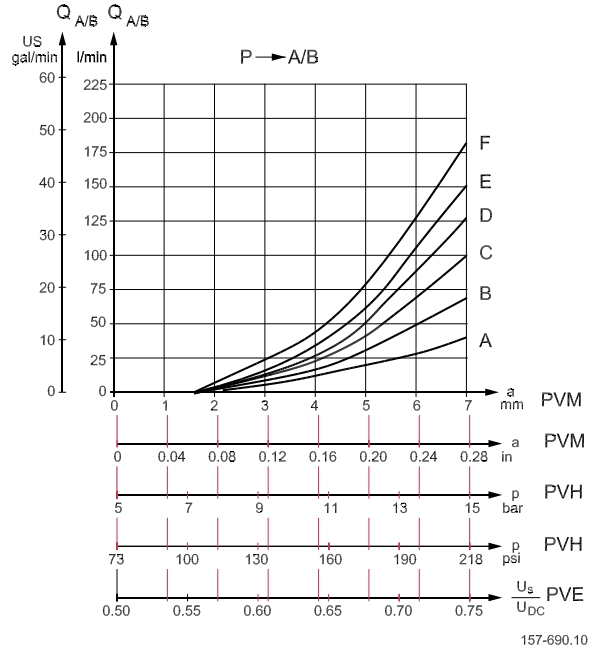

**PVB with pressure compensation, closed center PVP
 Oil flow as a function of spool travel for spools A to F**

Set pressure difference between pump pressure and LS signal = 20 bar [290 psi]
 measured at the P-port of the valve. For spool size reference [see page 22](#).

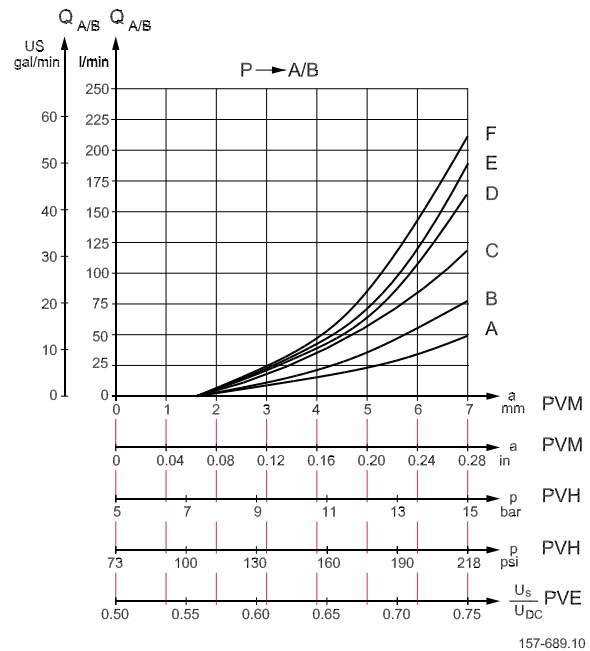

**PVLP,
Shock and
Suction Valve**

PVLP, Shock Valve

PVLP is set at an oil flow of 10 l/min [2.6 US gal/min].

The shock valve PVLP is designed to absorb shock effects. Consequently, it should not be used as a pressure relief valve.

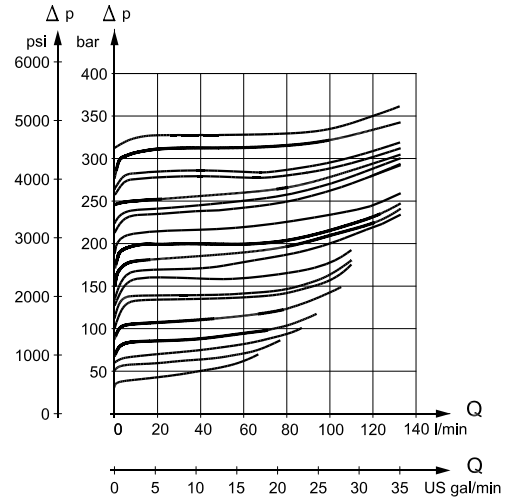

157-312.10

**PVLA,
Suction Valve**

PVLP/PVLA, Suction Valve

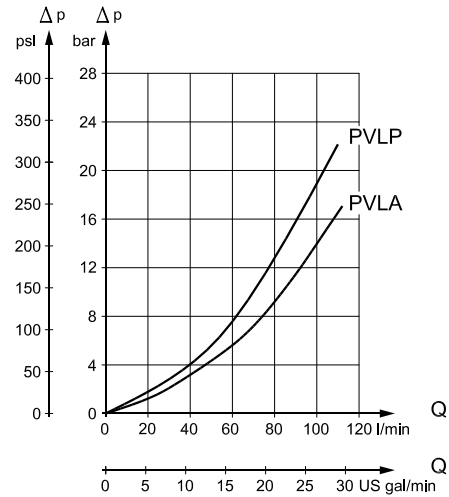

157-313.10

**Valve Dimension,
 PVG 100, Open Center
 PVPF**

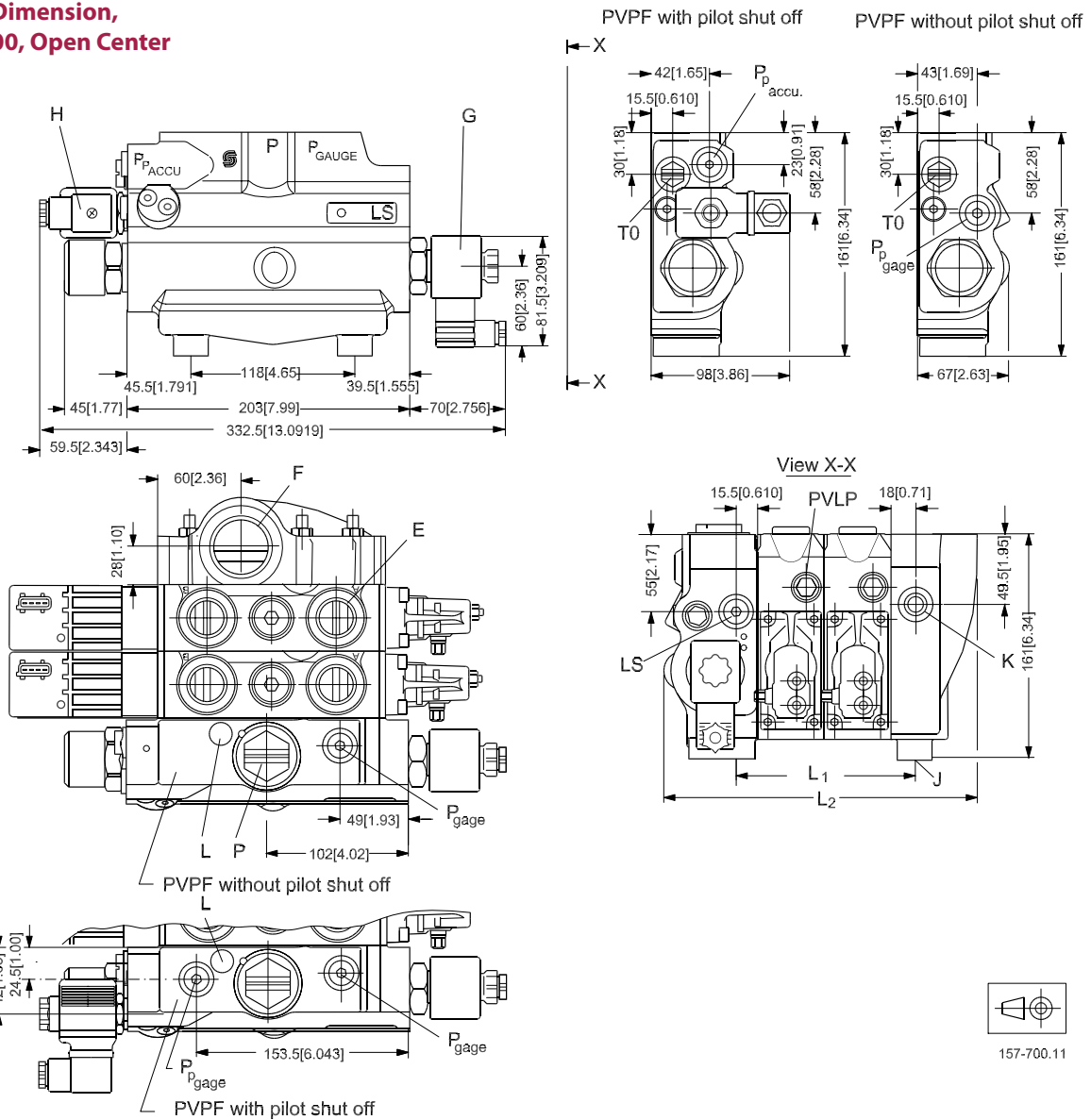

P_p accumulator connection : G¹/₄ [9/16 in - 18 UNF]

LS connection : G¹/₄ [9/16 in - 18 UNF]

P gage connection : G¹/₄ [9/16 in - 18 UNF]

T0 port connection : G¹/₄ [9/16 in - 18 UNF]

P_p gage connection : G¹/₄ [9/16 in - 18 UNF]

P: Pump port connection; G1 [1 5/8 in - 12 UNF]

G: PVPE unloading valve

F : Tank port connection; G 1 1/4 [1 5/8 in - 12 UNF]

H: PVPP pilot shut off valve

J : Mounting thread; M12 x 14 mm deep.

It is recommended to only use 3 of 4 mounting holes provided.

K : LX connection : G¹/₄ [9/16 in - 18 UNF]

L : LS relief valve

		1 PVB	2 PVB	3 PVB	4 PVB	5 PVB	6 PVB	7 PVB	8 PVB
L ₁	mm	80	128	176	224	272	320	368	416
	[in]	[3.15]	[5.04]	[6.93]	[8.82]	[10.71]	[12.60]	[14.49]	[16.38]
L ₂	mm	176	224	272	320	368	416	464	512
	[in]	[6.93]	[8.82]	[10.71]	[12.60]	[14.49]	[16.38]	[18.27]	[20.16]

Valve Dimension
PVG 100/32, Closed
Center PVPV

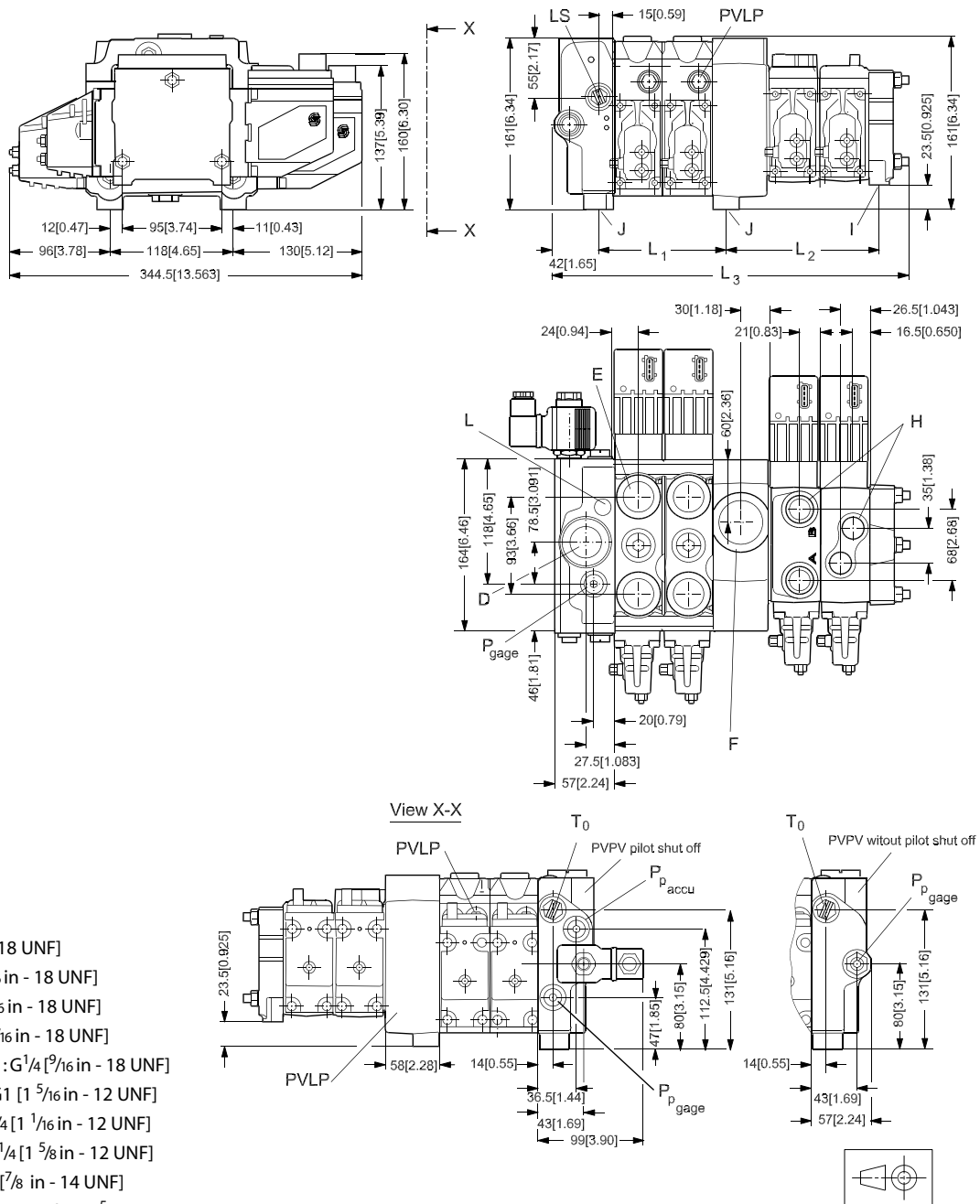

- LS connection : G¹/₄ [9/16 in - 18 UNF]
- P gage connection : G¹/₄ [9/16 in - 18 UNF]
- T₀ port connection : G¹/₄ [9/16 in - 18 UNF]
- P_p gage connection : G¹/₄ [9/16 in - 18 UNF]
- P_p accumulator connection : G¹/₄ [9/16 in - 18 UNF]
- D : Pump port connection; G¹/₄ [1 5/16 in - 12 UNF]
- E : Port A and B PVB 100; G³/₄ [1 1/16 in - 12 UNF]
- F : Tank port connection; G¹/₄ [1 5/8 in - 12 UNF]
- H : Port A and B PVB 32; G¹/₂ [7/8 in - 14 UNF]
- I : Mounting thread ; M8 x 15 mm deep [5/16 in - 18 UNC]
- J : Mounting thread ; M12 x 14 mm deep
- L : LS relief valve

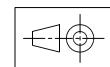

157-701.14

		1 PVB	2 PVB	3 PVB	4 PVB	5 PVB	6 PVB	7 PVB	8 PVB	9 PVB	10 PVB
L ₁	mm	80	128	176	224	272	320	368	416	-	-
	[in]	[3.15]	[5.04]	[6.93]	[8.82]	[10.71]	[12.60]	[14.49]	[16..38]	-	-
L ₂	mm	100	148	196	244	292	340	388	436	484	532
	[in]	[3.94]	[5.83]	[7.72]	[9.61]	[11.50]	[13.39]	[15.28]	[17.16]	[19.05]	[20.94]
L ₃	mm	-	245	293	341	389	437	485	533	581	629
	[in]	-	[9.64]	[11.54]	[13.43]	[15.31]	[17.20]	[19.09]	[20.98]	[22.87]	[24.76]

It is recommended not to exceed 10 PVB 100/32 in a valve group.

Valve Dimension
PVG 100, Closed Center
PVP with Integrated
Priority Valve

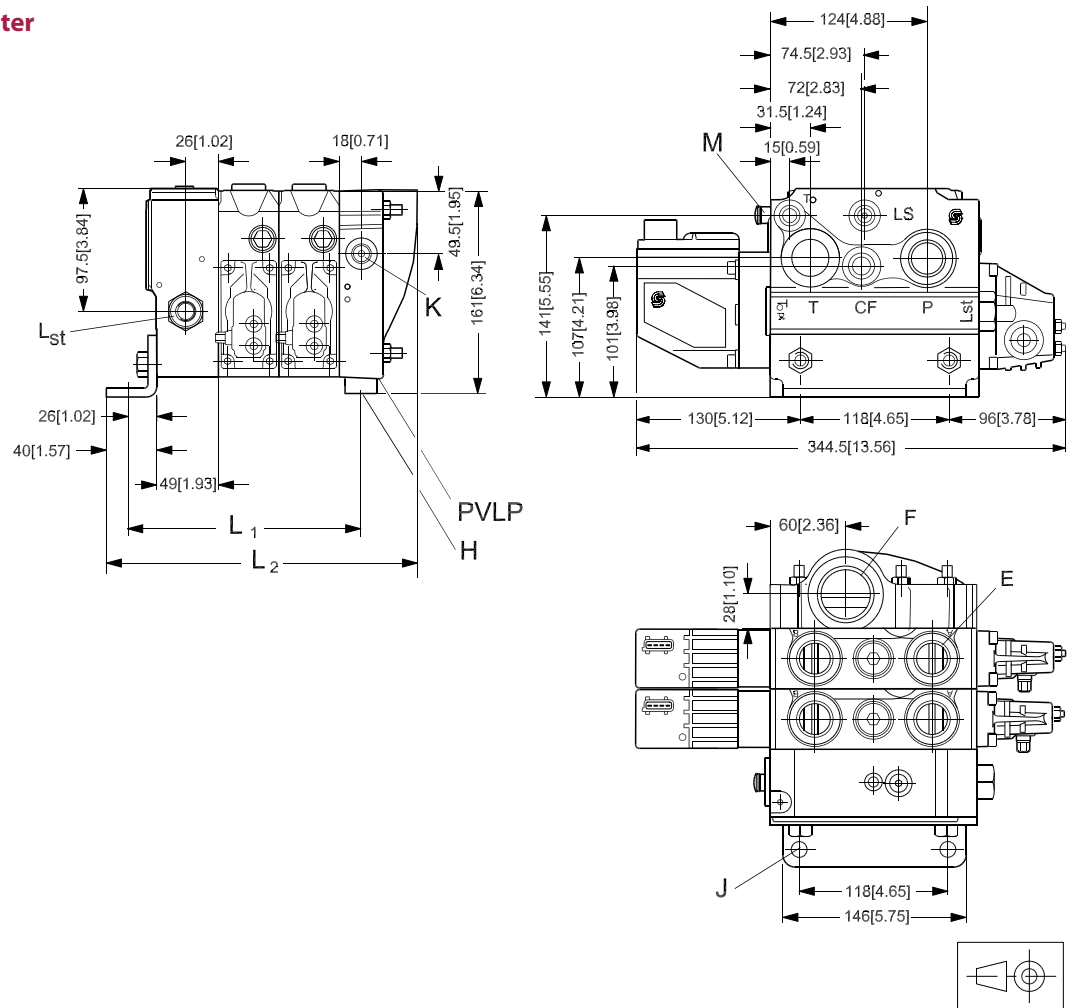

157-705.12

- CF connection : G¹/₂ [3/4 in - 16 UNF]
- LS connection : G¹/₄ [9/16 in - 18 UNF]
- P gage connection : G¹/₄ [7/16 in - 24 UNF]
- T0 port connection : G¹/₄ [9/16 in - 18 UNF]
- Pp gage connection : G¹/₄ [7/16 in - 24 UNF]
- P pump port connection; G³/₄ [1 1/16 in - 12 UNF]
- Lst: LS connection for steering unit; G¹/₄ [9/16 in - 18 UNF]
- E : Port A and B PVB 100; G³/₄ [1 1/16 in - 12 UNF]
- H : Mounting thread : M12 x 14 mm deep
- J : Mounting bracket with holes for M12 screws
- K : LX connection : G¹/₄ [9/16 in - 18 UNF]
- M : LS relief valve
- F : G¹/₄ [1 1/16 in]

		1 PVB	2 PVB	3 PVB	4 PVB	5 PVB	6 PVB	7 PVB	8 PVB
L ₁	mm	140	188	236	284	332	380	428	476
	[in]	[5.51]	[7.40]	[9.29]	[11.18]	[13.07]	[14.96]	[16.85]	[18.74]
L ₂	mm	198	246	294	342	390	438	486	534
	[in]	[7.80]	[9.69]	[11.57]	[13.46]	[15.35]	[17.24]	[19.13]	[21.02]

General Dimensions

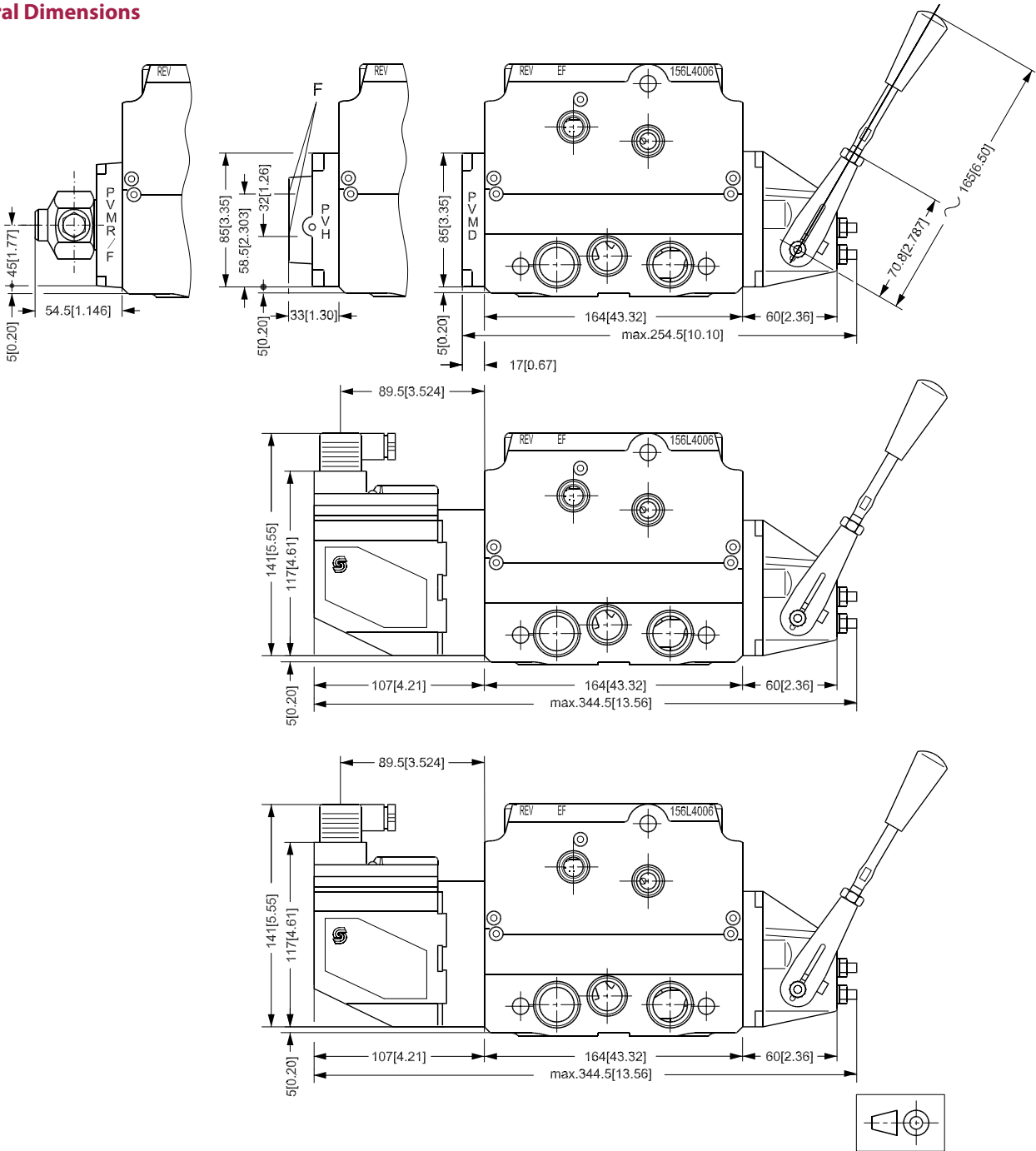

P301 064

**Example: PVG 100
 with Variable
 Displacement Pump**

**Refer to Page 31 for
 Specification Sheet**

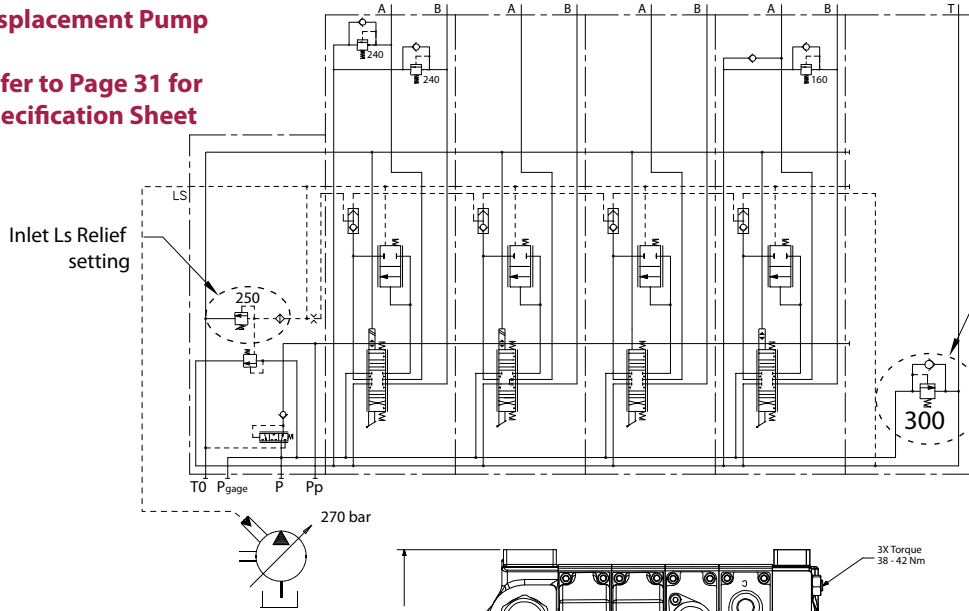

PVLP setting in PVT should be a minimum of 30 bar above setting on the pump or external relief valve

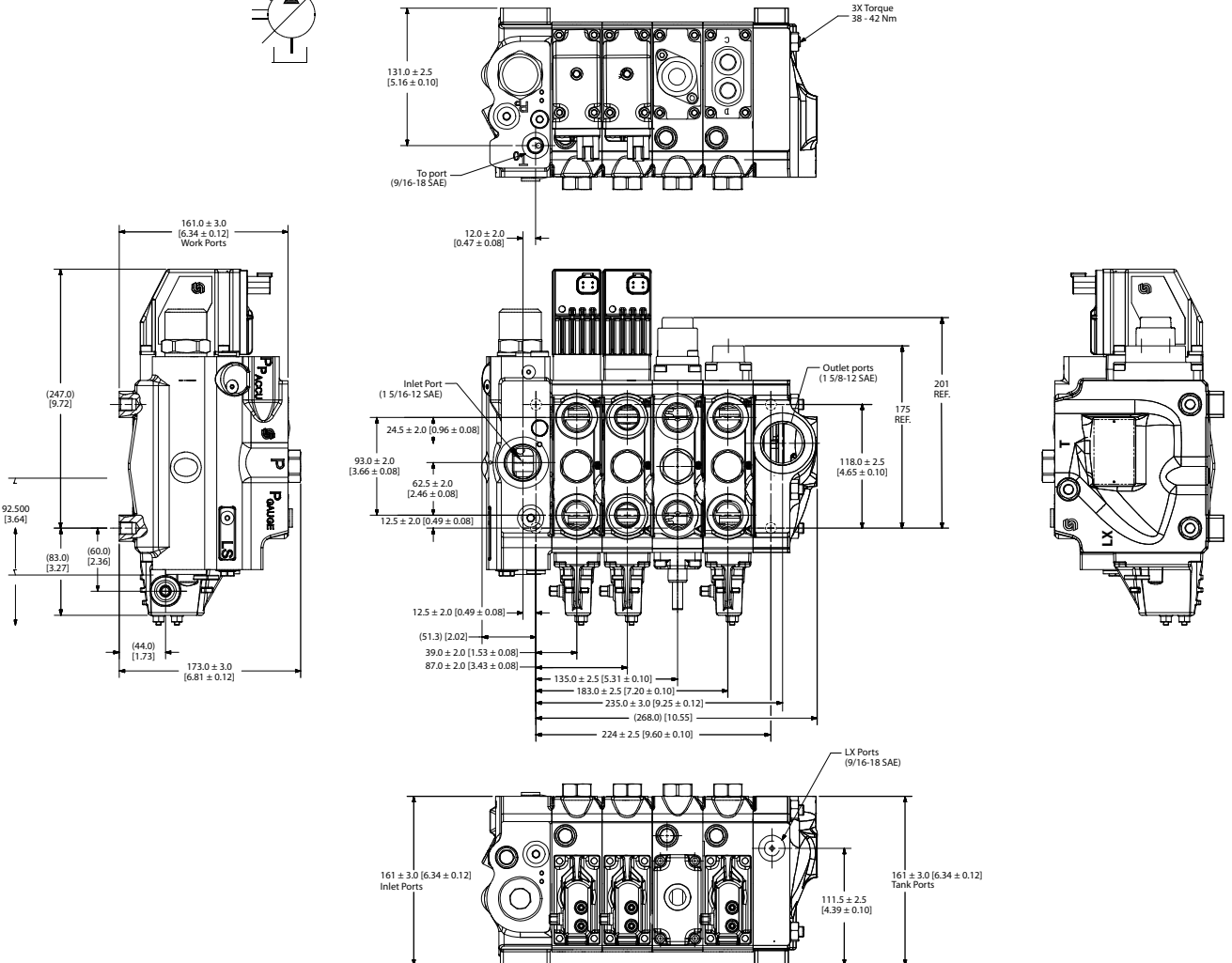

**Electrically Actuated PVG 100 Variable Displacement Pump
 PVB 100 with Integrated Pilot Operated Check Valves**

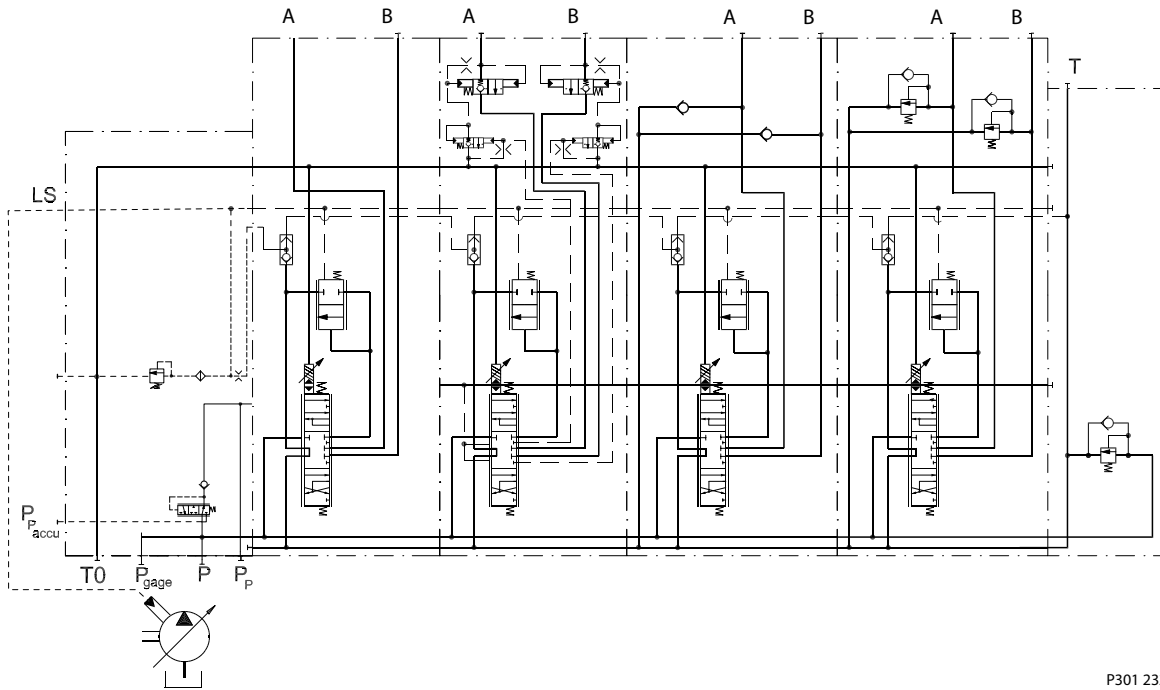

P301 232

**Electrically Actuated PVG 100/32 Fixed Displacement Pump
 PVB 100/32 with Integrated Pilot Operated Check Valves**

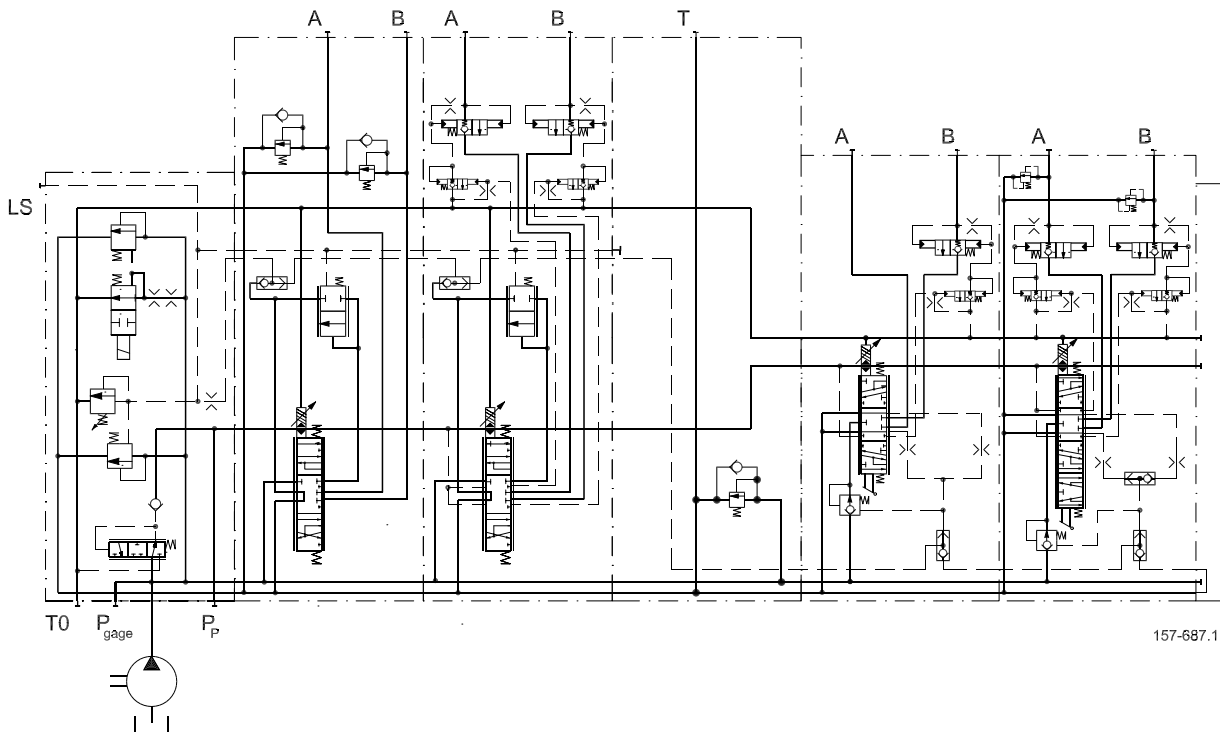

157-687.11

Subsidiary/Dealer	PVG No.
Customer	Customer No.
Application	Revision No.

Function ↓	A-Port ↓	0 161B5510 PVPF 155G5041 PVPE Plug 250 bar p = 3625 psi	B-Port ↓
	a 157B3173 PVM	1 161B6660 PVB 157B7024	157B4092 PVEH c
	b 157B2240 PVLP	LS _A psi LS _B psi	157B2240 PVLP b
	a 157B3173 PVM	2 161B6650 PVB 161B7122 PVBS 13	157B4092 PVEH c
	b	LS _A psi LS _B psi	b
Exposed End Spool	a	3 11051714 PVB-E 11051697 PVBS 13	c
	b 157B2280 PVLP	LS _A psi LS _B psi	157B2280 PVLP b
	a 157B3173 PVM	4 161B6660 PVB 161B9526 PVBS 13	157B0007 PVHA c
	b 157B2001 PVLA	LS _A psi LS _B psi	157B2160 PVLP b
	a	5	13 c
	b	LS _A psi LS _B psi	b
	a	6	13 c
	b	LS _A psi LS _B psi	b
	a	7	13 c
	b	LS _A psi LS _B psi	b
	a	8	13 c
	b	LS _A psi LS _B psi	b
	a	9	13 c
	b	LS _A psi LS _B psi	b
PVLP for PVT	a	10	13 c
	b 157B2280 PVLP	LS _A psi LS _B psi	b
Remarks		11 161B2520 PVT	
		12 157B8004 PVAS	

Filled in by	Date
--------------	------

Oil

The main duty of the oil in a hydraulic system is to transfer energy; but it must also lubricate the moving parts in hydraulic components, protect them against corrosion, and transport dirt particles and heat out of the system. It is therefore important to choose the correct oil with the correct additives. This gives normal operation and long working life.

Mineral oil

For systems with PVG 100 valves Sauer-Danfoss recommends the use of mineral-based hydraulic oil containing additives: Type HLP (DIN 51524) or HM (ISO 6743/4).

Non-flammable fluids

Phosphate-esters (HFDR fluids) can be used without special precautions. However, dynamic seals must be replaced with FPM (Viton) seals.

So please contact the Sauer-Danfoss Sales Organization if the PVG 100 valve is to be used with phosphate-esters.

The following fluids should only be used according to agreement with the Sales Organization for Sauer-Danfoss:

- Water-glycol mixtures (HFC fluids)
- Water-oil emulsions (HFB fluids)
- Oil-water emulsions (HFAE fluids)

Biodegradable oils

PVG 100 valves can be used in systems with rapeseed oil. The use of rapeseed oil is conditioned by

- complying with the demands on viscosity, water content, temperature and filtering etc. (*see chapters below and technical data page 7*).
- adapting the operating conditions to the directions of the oil supplier.

Before using other biodegradable fluids, please consult the Sauer-Danfoss Organization.

Particle Content, Degree of Contamination

Oil filtration must prevent particle content from exceeding an acceptable level, i.e. an acceptable degree of contamination.

Maximum contamination for PVG 100 is 23/19/16 (*see ISO 4406. Calibration in accordance with the ACFTD method*).

In our experience a degree of contamination of 23/19/16 can be maintained by using a filter fineness as described in the next section.

Filtration

Effective filtration is the most important precondition in ensuring that a hydraulic system performs reliably and has a long working life. Filter manufacturers issue instructions and recommendations. It is advisable to follow them.

System filters

Where demands on safety and reliability are very high a pressure filter with bypass and indicator is recommended. Experience shows that a 10 µm nominal filter (or finer) or a 20 µm absolute filter (or finer) is suitable.

It is our experience that a return filter is adequate in a purely mechanically operated valve system.

The fineness of a pressure filter must be selected as described by the filter manufacturer so that a particle level of 23/19/16 is not exceeded.

The filter must be fitted with pressure gauge or dirt indicator to make it possible to check the condition of the filter.

In systems with differential cylinders or accumulators the return filter must be sized to suit the max. return oil flow. Pressure filters must be fitted to suit max. pump oil flow.

Internal filters

The filters built into PVG 100 are not intended to filter the system but to protect important components against large particles. Such particles can appear in the system as a result of pump damage, hose fracture, use of quick-couplings, filter damage, starting up, contamination, etc.

The filter in the electrical actuator PVE protecting the solenoid valves has a mesh of 150 µm.

Bursting pressure drop for internal filters is 25 bar [360 psi].

**PVBS Spool
 Sub-Assemblies**

Standard Mounting - vs - Option Mounting

Standard Mounting is defined as installing the PVM on the "A" port side of the PVB. Because of this, the PVE or PV cover (PVH, PVMD, PVMR, PVMF or PVHC) would be on the "B" port side of the valve.

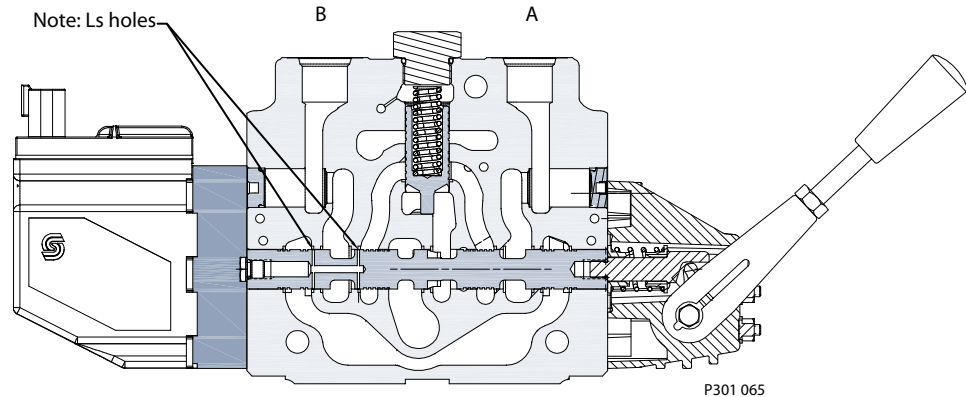

Standard Mounted Work Section

Option Mounting is defined as installing the PVM on the "B" port side of the PVB. Because of this, the PVE or PV cover (PVH, PVMD, PVMR, PVMF or PVHC) would be on the "A" port side of the valve.

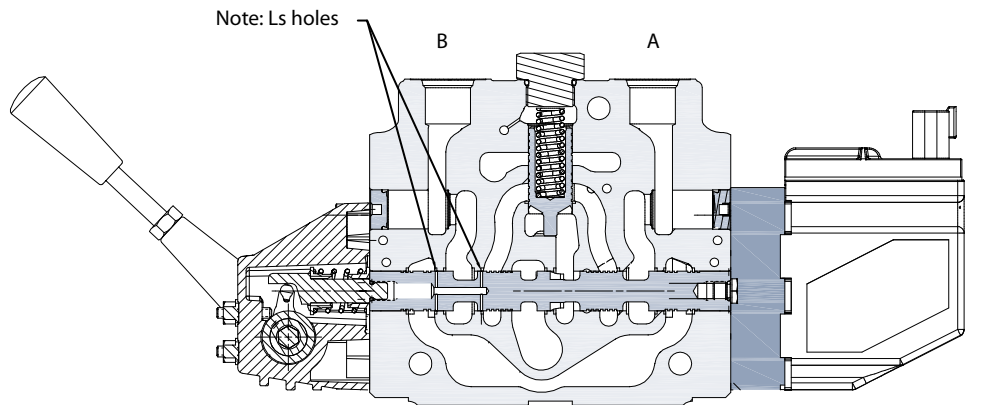

Option Mounted Work Section

**PVBS Spool
 Sub-Assemblies**



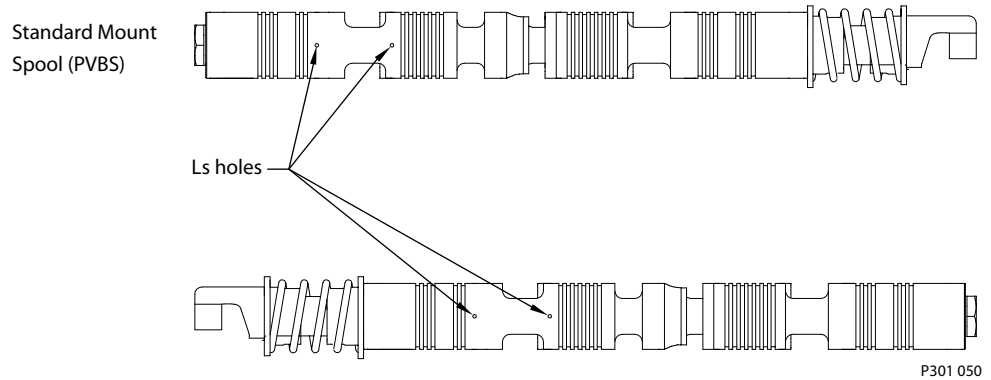

Standard Mounting - vs - Option Mounting

The PVBS in PVG 100 are **not symmetric**. Because of this the "Load Sense" (Ls) holes in the PVBS main spool must be installed so that they are on the "B" port side of the PVB.



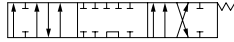
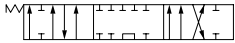
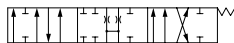

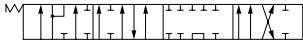

Before determining spool part numbers, determine whether the section will be Standard or option mounted. Standard and Option mounting only applies to a work section. Standard and option mounted section can be used together in the same stack.

Standard Spools (Electrical and Mechanical Actuation)

Symbol	Pressure Compensated Flow l/min [gpm]*					
	A 40 [10.6]	B 65 [17.2]	C 100 [26.4]	D 130 [34.4]	E 150 [39.6]	F 180 [47.6]
4-way, 3 position, Closed Neutral Position						
Standard Mount 	161B7022	161B7023	161B7024	161B7025	161B7026	161B7027
Option Mount  P301 058	11013079	11013080	11013081	11013082	11013083	11013084
4-way, 3-position, Throttled Open Neutral Position						
Standard Mount 	161B7122	161B7123	161B7124	161B7125	161B7126	161B7127
Option Mount  P301 059	11013085	11013086	11013087	11013088	11013089	11013090
4-way, 4-position, Closed Neutral Position, Electric float P → A → F						
Standard Mount 	161B7622	161B7623	161B7624	161B7625	161B7626	161B7627
Option Mount  P301 060	11013091	11013092	11013093	11013094	11013095	11013096
4-way, 3-position, Throttled Open Neutral Position Electric Float P → A → F						
Standard Mount 	11016865	11016866	11016867	11016868	11016869	11016870
Option Mount  P301 060	11016871	11019872	11016873	11016874	11016875	11016876

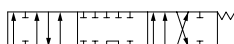
* Specified flow is at 15 bar pump margin pressure.

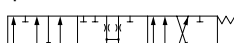
Standard Spools (Hydraulic Actuation)

Symbol	Pressure Compensated Flow l/min [gpm]*					
	A 40 [10.6]	B 65 [17.2]	C 100 [26.4]	D 130 [34.4]	E 150 [39.6]	F 180 [47.6]
4-way, 3 position, Closed Neutral Position						
Standard Mount 	161B9522	161B9523	161B9524	161B9525	161B9526	161B9527
Option Mount  P301 058	11013097	11013098	11013099	11013100	11013101	11013102
4-way, 3-position, Throttled Open Neutral Position						
Standard Mount 	161B9622	161B9623	161B9624	161B9625	161B9626	161B9627
Option Mount  P301 059	11013103	11013104	11013105	11013106	11013107	11013108

* Specified flow is at 15 bar pump margin pressure.

*Spools for Friction Detent: PVMR***

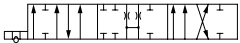
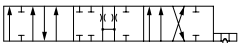
Symbol	Pressure Compensated Flow l/min [gpm]*					
	A 40 [10.6]	B 65 [17.2]	C 100 [26.4]	D 130 [34.4]	E 150 [39.6]	F 180 [47.6]
4-way, 3-position, Throttled Open Neutral Position Standard Mount 	161B9732	161B9733	161B9734	161B9735	161B9736	161B9737
Option Mount  P301 061	11013109	11013110	11013111	11013112	11013113	11013114

* Specified flow is at 15 bar pump margin pressure.
 ** PVMR (frict. detent) not compatible with PVBZ 100

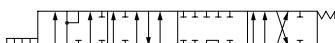
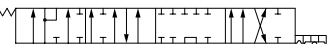

*Spools for Float: PVMF***

Symbol	Pressure Compensated Flow l/min [gpm]*					
	A 40 [10.6]	B 65 [17.2]	C 100 [26.4]	D 130 [34.4]	E 150 [39.6]	F 180 [47.6]
4-way, 3 position, Throttled Open Neutral Position Standard Mount 	161B9822	161B9823	161B79824	161B9825	161B9826	161B9827
Option Mount  P301 062	11013115	11013116	11013117	11013118	11013119	11013120

* Specified flow is at 15 bar pump margin pressure.
 ** PVMF (mech. float position) not compatible with PVBZ 100

Standard Spools (Electrical and Mechanical Actuation)

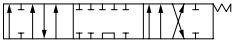
Linear Flow Characteristics

Symbol	Pressure Compensated Flow l/min [gpm]*					
	A 40 [10.6]	B 65 [17.2]	C 100 [26.4]	D 130 [34.4]	E 150 [39.6]	F 180 [47.6]
4-way, 3 position, Closed Neutral Position Standard Mount 	11016852	11016823	11016854	11016855	11016857	11016858
Option Mount  P301 058	11016859	11016860	11016861	11016862	11016863	11016864

* Specified flow is at 15 bar pump margin pressure.

Exposed Spools: The following spools are available with an exposed tang for mechanical actuation. These spools are only available for standard mounting.

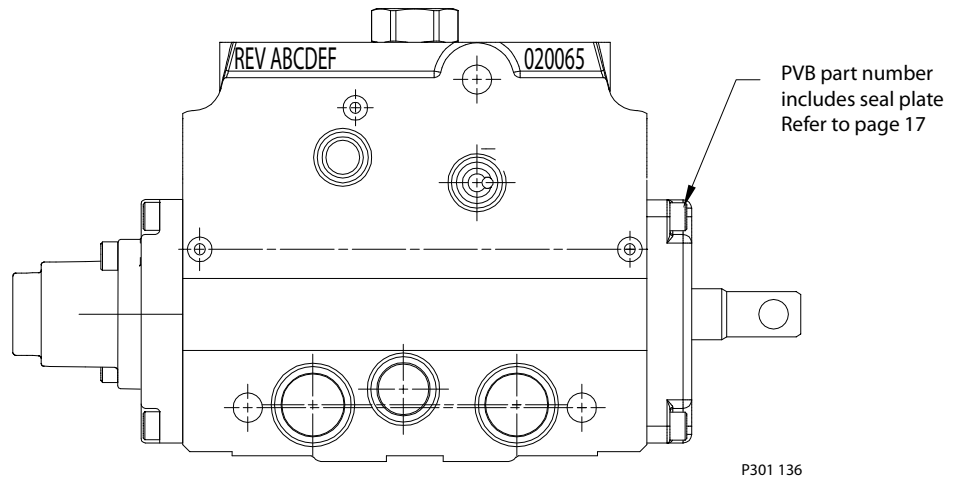

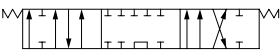
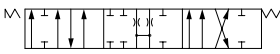
Symbol	Pressure compensated flow l/min [gpm]*					
	A 40 [10.6]	B 65 [17.2]	C 100 [26.4]	D 130 [34.4]	E 150 [39.6]	F 180 [47.6]
4-Way, 3-Position, Closed Neutral Position Standard Mount  P301 138	11051695	11051696	11051697	11051698	11051699	11051700
4-Way, 3-Position, Throttled Open Standard Mount  P301 139	11051701	11051702	11051703	11051704	11051705	11051706

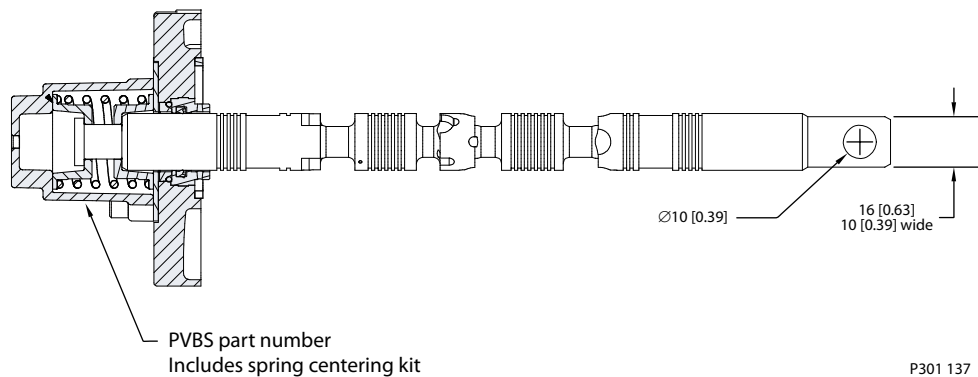

Building in Safety

All makes and all types of control valves (incl. proportional valves) can fail. Thus the necessary protection against the serious consequences of function failure should always be built into the system. For each application an assessment should be made for the consequences of pressure failure and uncontrolled or blocked movements.

To determine the degree of protection that is required to be built into the application, system tools such as an FMEA (Failure Mode and Effect Analysis) and Hazard and Risk Analysis can be used.

FMEA (Failure Mode and Effect Analysis) IEC EN 61508

FMEA is a tool used for analyzing potential risks. This analytical technique is utilized to define, identify, and prioritize the elimination or reduction of known and/or potential failures from a given system before it is released for production.

Please refer to IEC FMEA Standard 61508.

Hazard and Risk Analysis ISO 12100-1 / 14121

This analysis is a tool used in new applications as it will indicate whether there are special safety considerations to be met according to the machine directives EN 13849. Dependent on the determined levels conformity this analysis will determine if any extra requirements for the product design, development process, production process or maintenance, i.e. the complete product life cycle.

▲ Warning

All makes/brands and types of directional control valves – inclusive proportional valves – can fail and cause serious damage. It is therefore important to analyze all aspects of the application.

Because the proportional valves are used in many different operation conditions and applications, the manufacturer of the application is alone responsible for making the final selection of the products – and assuring that all performance, safety and warning requirements of the application are met.

The process of choosing the control system – and safety levels – is governed by the machine directives EN 13849 (Safety related requirements for control systems).

Control System Example

Example of a control system for manlift using PVE Fault monitoring input signals and signals from external sensors to ensure the PLUS+1™ main controllers correct function of the manlift.

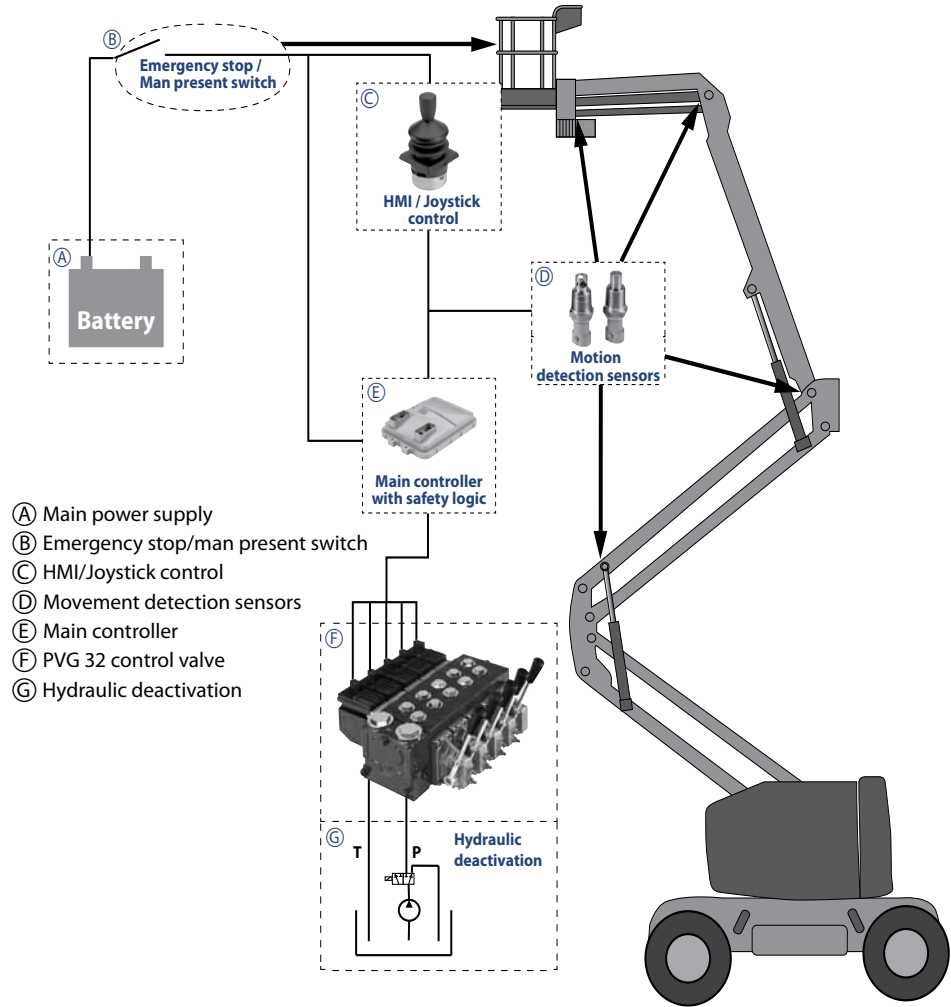

Electrical block diagram for above illustration

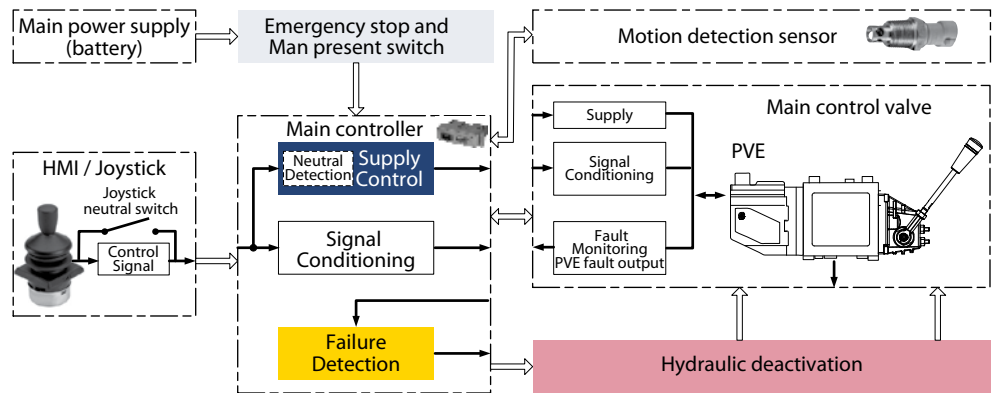

Warning

It is the responsibility of the equipment manufacturer that the control system incorporated in the machine is declared as being in conformity with the relevant machine directives.

**Control System Example
(continued)**

Example of a typical wiring block diagram using PVEH with neutral power off switch and fault monitoring output for hydraulic deactivation.

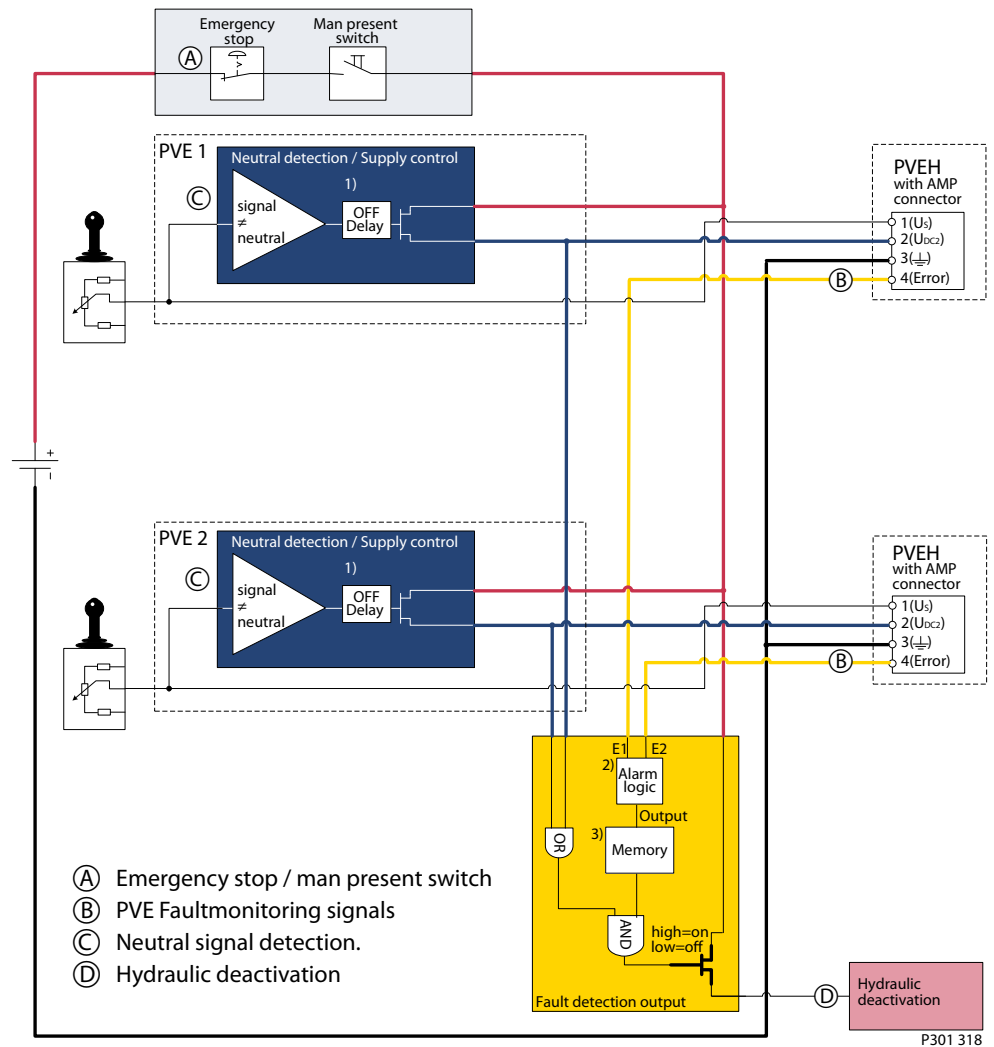

System Control Logic e.g. PLUS+1™ for signal monitoring and triggering signal for deactivation of the hydraulic system.

Warning

It is the responsibility of the equipment manufacturer that the control system incorporated in the machine is declared as being in conformity with the relevant machine directives.

**Control System Example
 (continued)**

Example of fault monitoring for deactivation of the hydraulic system with extra fault inputs using the PVE's with DI (Direction Indication) function.

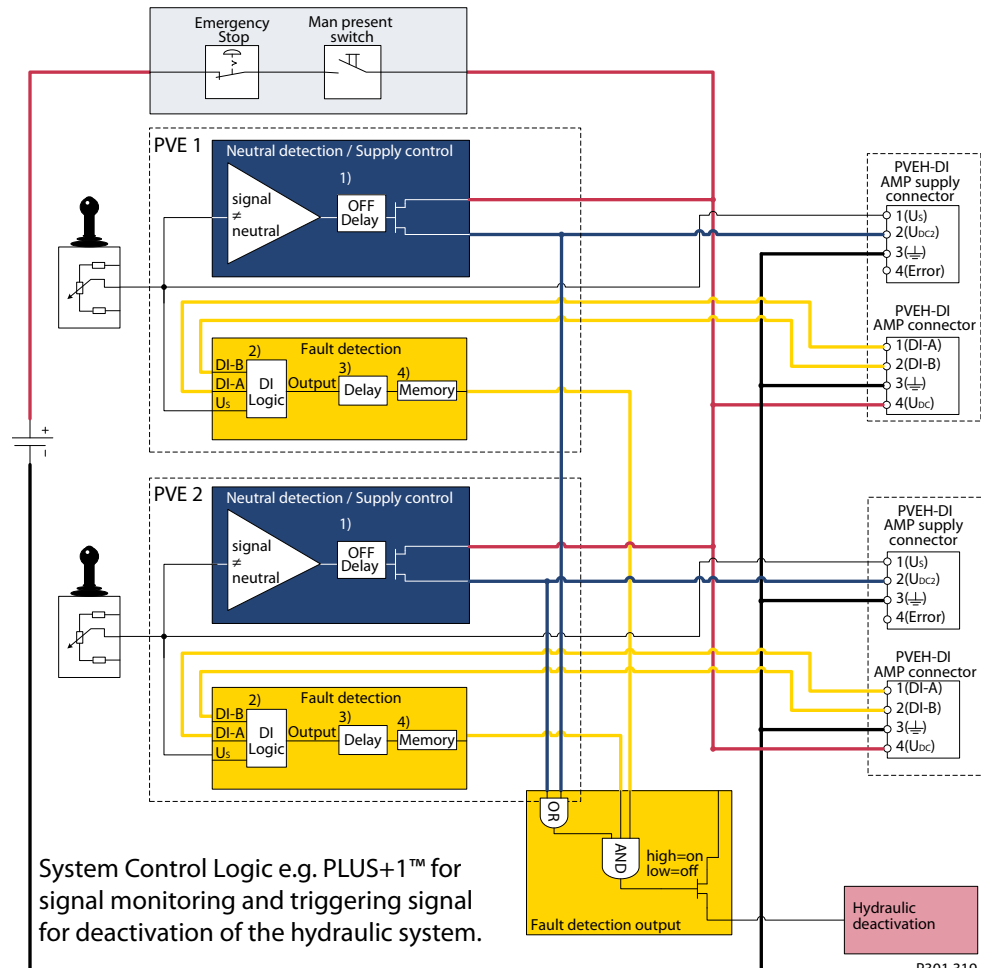

⚠ Warning

It is the responsibility of the equipment manufacturer that the control system incorporated in the machine is declared as being in conformity with the relevant machine directives.

Other non-electrical modules which can be used in connection with hydraulic deactivation at different levels.

PVG32 – Mainly used in system with fixed displacement pumps

- PVSK, commonly used in crane application - full flow dump
- PVPX, LS dump to tank

PVG100 – Alternative LS dump or pilot supply disconnect

- PVPP, pilot oil supply shut off
- External cartridge valve connecting LS Pressure to Tank
- External cartridge valve connecting main Pressure to Tank

PVG120 – Pump disconnect/block for variable pumps

- PVPE, full flow dump for the PVG 120



PVG 100 Proportional Valve
Technical Information
Notes

PVB, basic module

Code no.	No facilities for shock valves A and B		Facilities for shock valves A and B	
	G 3/4	1 1/16 in-14	G 3/4	1 1/16 in-14
Without pilot operated check valve	161B6250	161B6650	161B6260	161B6660
With pilot operated check valve	161B6252	161B6652	161B6262	161B6662
Exposed spools PVB	11051707	11051708	11051709	11051710
Exposed spools PVBZ	11051711	11051712	11051713	11051714
Endmodule	-	-	11006889	-
Module with tank port in bottom	-	-	11006887	-
PVB module, twin shock valve	-	-	-	11077581*
Weight kg [lb]	5.5 kg [12.13 lb]			

* For high flow applications

PVM, mechanical actuation

Code no. 157B....	With stop screw	Without stop screw	
Standard	3171*	3191	22.5°
	3161**		
	3172	-	37.5°
Standard, with base, without arm and button	3174	3194	37.5°
	3175	3195	22.5°
Standard, without base, arm and button	3173	3193	-
Weight kg [lb]	0.4 [0.9]		

* Anodized 157B3184

** Cast iron

Assembly Kit PVG 100 / PVSI / PVPT

Description	Code number 161B....							
	1 PVB	2 PVB	3 PVB	4 PVB	5 PVB	6 PVB	7 PVB	8 PVB
Tie bolts and seals	8001	8002	8003	8004	8005	8006	8007	8008

Assembly Kit PVG 100 / PVTI Interface Module

Description	Code number 161B....							
	1 PVB	2 PVB	3 PVB	4 PVB	5 PVB	6 PVB	7 PVB	8 PVB
Tie bolts and seals	8021	8022	8023	8024	8025	8026	8027	8028

Assembly Kit PVB 32

Description	Code number 157B....									
	1 PVB	2 PVB	3 PVB	4 PVB	5 PVB	6 PVB	7 PVB	8 PVB	9 PVB	10 PVB
PVB's	8000	8001	8002	8003	8004	8005	8006	8007	8008	8009
Weight [kg [lb]]	0.1 [0.2]	0.15 [0.3]	0.25 [0.6]	0.30 [0.7]	0.40 [0.9]	0.45 [1.0]	0.50 [1.1]	0.60 [1.3]	0.65 [1.4]	0.70 [1.6]

PVLP, shock/and anti-cavitation valves

Code no. 157B...	2032	2050	2063	2080	2100	2125	2140	2150	2160	2175	2190	2210	2230	2240	2250	2265	2280	2300	2320	2350	
Setting	bar	32	50	63	80	100	125	140	150	160	175	190	210	230	240	250	265	280	300	320	350
	[psi]	460	725	914	1160	1450	1813	2031	2175	2320	2538	2755	3045	3335	3480	3625	3845	4061	4351	4641	5075
Weight [kg [lb]]	0.05 kg [0.17 lb]																				

PVPC (for details see catalog, 520L0344)

Code no. 157B...	G 1/4	9/16 in - 18 UNF	Weight	
			kg	[lb]
External pilot supply	5400	-	0.05	0.1
External pilot supply incl. check valve	5600	5625	0.05	0.1

Not available for PVPV 157B5211 and 157B5611

PVTI 100/32 interface module

Code no. 161B...	BSP	SAE	Weight	
			kg	[lb]
PVTI, with T-port and PVLP facility	2200	2220	8.7	[19.18]

T-connection G 1 1/4 [1 5/8 UN]

Tank Module, PVT

Code no. 161B...	BSP	SAE	Weight	
			kg	[lb]
PVT, with T-port and PVLP facility	2500	2520	6.3 kg	[13.89]
PVT, with LX connection, T-port and PVLP facility	2505	2525		

T-connection G 1 1/4 [1 5/8 UN]

PVP 100, Pump Side Module

Code no. 161B... or 11XXXXXX	Closed center, PVPV With pilot supply						Open center, PVPF With pilot supply							
	for PVE and facility for pilot shut off		for PVE With integrated priority function	for PVH/ PVHC	for PVH/PVHC and facility for pilot shut off	for PVH/ PVHC With integrated priority function	for PVE		for PVE and facility for pilot shut off		for PVH/PVHC		for PVH/PVHC and facility for pilot shut off	
	12 bar	20 bar				12 bar	20 bar	12 bar	20 bar	12 bar	20 bar	12 bar	20 bar	
P-port = G 1	5111	5141	-	11013069	11013075	-	5110	5112	5140	5142	11013065	11013067	11013071	11013073
P-port = 1 5/16 UN	5511	5541	-	11013070	11013076	-	5510	5512	5540	5542	11013066	11013068	11013072	11013074
P-port = G 3/4, T-port = G1	-	-	5211	-	-	11013077	-	-	-	-	-	-	-	-
P-port = G 1 1/16 UN, T-port = 1 5/16 UN	-	-	5611	-	-	11013078	-	-	-	-	-	-	-	-
Weight	kg [lb]					8.5 kg [12.30 lb]								

Accessory Moduls for PVP 100

Code no.		Weight kg [lb]
Plug, PVPD	155G5041*	0.4 [0.9]
Elec. unloading 12 V valve, PVPE	155G5052*	0.7 [1.1]
24 V	155G5054*	
Pilot shut off 12 V valve, PVPP	800572719	0.3 [0.7]
24 V	800572819	

* For PVPF only

PVE, Electrical Actuation

Code no. 157B...		Code No.			Weight kg [lb]
		Hirsch	AMP	Deutsch	
PVEO, on-off	12 V	4216	4901	4291	0.6 [1.3]
	24 V	4228	4902	4292	0.6 [1.3]
PVEO-R, on/off	12 V	4217	4903	-	0.6 [1.3]
	24 V	4229	4904	-	0.6 [1.3]
PVEA, active fault mon.	-	4734	4792	-	0.9 [2.0]
PVEA, passive fault mon.	-	4735	-	-	0.9 [2.0]
PVEA-DI, active fault mon.	-	4736	4796	-	0.9 [2.0]
PVEA-DI, passive fault mon.	-	4737	-	-	0.9 [2.0]
PVEH active fault mon.	4032	4034	4092	-	1.0 [2.2]
PVEH passive fault mon.	4033	4035	-	-	1.0 [2.2]
PVEH-F float pos. act. fault	-	4338	-	-	1.0 [2.2]
PVEH- DI active fault mon.	-	4036	4096	-	1.0 [2.2]
PVEH- DI passive fault mon.	-	4037	-	-	1.0 [2.2]
PVEP active fault mon.	-	-	4752	4793	1.0 [2.2]
PVEP-F float pos. act. fault	-	-	-	-	1.0 [2.2]
PVES, active fault mon.	4832	4834	4892	-	1.0 [2.2]
PVES, passive fault mon.	4833	4835	-	-	1.0 [2.2]
PVED-CC, Can-bus interface	-	4943	4944	-	1.0 [2.2]

PVHC

PVHC High Current PWM Actuator		
Voltage	Connector	Code no
12 V	Amp	11061228
24 V	Amp	11061227
12 V	Deutsch	11061229
24 V	Deutsch	11061230

PVLA, Anti-Cavitation Valve

Code no. 157B...	Code No.	Weight kg [lb]	
		kg	[lb]
Cap A or B	2002	0.04	0.09
Valve A or B	2001	0.05	0.1

PVMD, PVH, PVMR, PVMF Covers

Code no. 157B...	Code No.	Weight kg [lb]	
		kg	[lb]
Cover for PVM	0001	0.1	0.2
Hydraulic actuation PVH G 1/4	0008	0.2	0.4
Hydraulic actuation PVH 9/16-18 UNF	0007	0.9	2.0
PVMR (frict. detent)	0015	0.3	0.6
PVMF (mech. float position)	0005	0.3	0.6

Order specification

An order form for Sauer-Danfoss PVG 100 hydraulic valve is shown on the next page. The form can be obtained from the Sauer-Danfoss Sales Organization.

Both the module selection chart on the previous pages and the order form are divided into fields 0, 1-10, 11, 12, 13, a, b, and c.

Each module has its own field:

- 0: Pump side module PVP
 - Plug for external pilot oil supply PVPC
 - Electrical unloading valve PVPE
 - Electrical pilot shut off valve PVPE
- 1-10: Basic valves PVB
- 13: Main spool PVBS
 - a: Mechanical actuator PVM
 - c: Cover for mechanical actuation PVMD
 - Cover for hydraulic actuation PVH
 - Electrical actuators PVE
 - b: Shock and suction valve PVLP
 - Suction valve PVLA
- 11: End plate PVSI
 - Tank module PVT
 - Interface module PVTI
- 12: Assembly kit PVAS

Please state

- Code numbers of all modules required
- Required setting (P) for pump side module

Standard and option assembly

The PVG 100 valve group is assembled the way the module selection chart shows if the code number for PVM is written in field a, and the code number for PVMD, PVE or PVH in field c.

The valve group is assembled so that the mechanical actuator is mounted on the opposite end of the basic module, if the code number for PVM is written in field c of the order form and the code numbers for PVMD, PVE or PVH in field a.

Reordering

The space at the top right-hand corner of the form is for Sauer-Danfoss to fill in. The code number for the whole of the specified valve group (PVG No.) is entered here. In the event of a repeat order all you have to do is enter the number Sauer-Danfoss has given on the initial confirmation of order.

Subsidiary/Dealer	PVG No.
Customer	Customer No.
Application	Revision No.

Function	A-Port	0 161B _____ p = _____ bar _____	B-Port
	a 157B	1 _____ 13	157B c
	b 157B	LS _A _____ bar LS _B _____ bar	157B b
	a 157B	2 _____ 13	157B c
	b 157B	LS _A _____ bar LS _B _____ bar	157B b
	a 157B	3 _____ 13	157B c
	b 157B	LS _A _____ bar LS _B _____ bar	157B b
	a 157B	4 _____ 13	157B c
	b 157B	LS _A _____ bar LS _B _____ bar	157B b
	a 157B	5 _____ 13	157B c
	b 157B	LS _A _____ bar LS _B _____ bar	157B b
	a 157B	6 _____ 13	157B c
	b 157B	LS _A _____ bar LS _B _____ bar	157B b
	a 157B	7 _____ 13	157B c
	b 157B	LS _A _____ bar LS _B _____ bar	157B b
	a 157B	8 _____ 13	157B c
	b 157B	LS _A _____ bar LS _B _____ bar	157B b
	a 157B	9 _____ 13	157B c
	b 157B	LS _A _____ bar LS _B _____ bar	157B b
	a 157B	10 _____ 13	157B c
	b 157B	LS _A _____ bar LS _B _____ bar	157B b
Remarks		11 _____	
		12 _____	

Filled in by	Date
--------------	------



Products we offer:

- Bent Axis Motors
- Closed Circuit Axial Piston Pumps and Motors
- Displays
- Electrohydraulic Power Steering
- Electrohydraulics
- Hydraulic Power Steering
- Integrated Systems
- Joysticks and Control Handles
- Microcontrollers and Software
- Open Circuit Axial Piston Pumps
- Orbital Motors
- PLUS+1™ GUIDE
- Proportional Valves
- Sensors
- Steering
- Transit Mixer Drives

Members of the Sauer-Danfoss Group:

Comatrol

www.comatrol.com

Schwarz Müller-Inverter

www.schwarzmueller-inverter.com

Turolla

www.turollaocg.com

Hydro-Gear

www.hydro-gear.com

Sauer-Danfoss-Daikin

www.sauer-danfoss-daikin.com

Sauer-Danfoss is a global manufacturer and supplier of high-quality hydraulic and electronic components. We specialize in providing state-of-the-art technology and solutions that excel in the harsh operating conditions of the mobile off-highway market. Building on our extensive applications expertise, we work closely with our customers to ensure exceptional performance for a broad range of off-highway vehicles.

We help OEMs around the world speed up system development, reduce costs and bring vehicles to market faster.

Sauer-Danfoss – Your Strongest Partner in Mobile Hydraulics.

Go to www.sauer-danfoss.com for further product information.

Wherever off-highway vehicles are at work, so is Sauer-Danfoss.

We offer expert worldwide support for our customers, ensuring the best possible solutions for outstanding performance. And with an extensive network of Global Service Partners, we also provide comprehensive global service for all of our components.

Please contact the Sauer-Danfoss representative nearest you.

Local address:

Sauer-Danfoss (US) Company
2800 East 13th Street
Ames, IA 50010, USA
Phone: +1 515 239 6000
Fax: +1 515 239 6618

Sauer-Danfoss ApS
DK-6430 Nordborg, Denmark
Phone: +45 7488 4444
Fax: +45 7488 4400

Sauer-Danfoss GmbH & Co. OHG
Postfach 2460, D-24531 Neumünster
Krokamp 35, D-24539 Neumünster, Germany
Phone: +49 4321 871 0
Fax: +49 4321 871 122

Sauer-Danfoss-Daikin LTD.
Shin-Osaka TERASAKI 3rd Bldg. 6F
1-5-28 Nishimiyahara, Yodogawa-ku
Osaka 532-0004, Japan
Phone: +81 6 6395 6066
Fax: +81 6 6395 8585