

# **Comatrol**

**RESPONSIVENESS IN MOTION**

*Member of the Danfoss Group*



## **Check Valves**

**[www.comatrol.com](http://www.comatrol.com)**

Cartridge	Model No.	Cavity	Description	Flow*	Pressure	Page
	CV04-NB	CP04-2	Check Valve, Ball Type, Normal Direction	3 l/min [0.8 US gal/min]	207 bar [3000 psi]	CV - 7

Cartridge	Model No.	Cavity	Description	Flow*	Pressure	Page
	CV08-NP	SDC08-2	Check Valve, Poppet Type, Normal Direction	38 l/min [10 US gal/min]	350 bar [5075 psi]	CV - 8
	CV10-NP	SDC10-2		80 l/min [21.1 US gal/min]	350 bar [5075 psi]	CV - 9
	CP102-1	SDC16-2		210 l/min [55.5 US gal/min]	315 bar [4570 psi]	CV - 10
	CP103-1	SDC20-2		330 l/min [87.2 US gal/min]	215 bar [3120 psi]	CV - 11

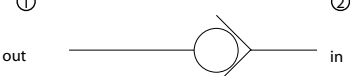
Cartridge	Model No.	Cavity	Description	Flow*	Pressure	Page
	CP104-2	CP04-2	Check Valve, Reverse Direction, No Spring	4.5 l/min [1.2 US gal/min]	350 bar [5075 psi]	CV - 12

\* Flow ratings are based on a pressure drop of 7 bar [100 psi] unless otherwise noted. They are for comparison purposes only.

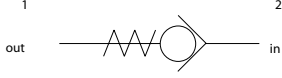
Cartridge	Model No.	Cavity	Description	Flow*	Pressure	Page
	CP108-2	SDC08-2	Check Valve, Reverse Direction	20 l/min [5 US gal/min]	350 bar [5075 psi]	CV - 13
	CP100-2	SDC10-2		50 l/min [13 US gal/min]	350 bar [5075 psi]	CV - 14
	CP101-2	CP12-2		75 l/min [20 US gal/min]	350 bar [5075 psi]	CV - 15
	CP102-2	SDC16-2		150 l/min [40 US gal/min]	350 bar [5075 psi]	CV - 16
	CP103-2	SDC20-2		265 l/min [70 US gal/min]	350 bar [5075 psi]	CV - 17

Slip-in	Model No.	Cavity	Description	Flow*	Pressure	Page
	3C50-01	FC-144	Check Valve, Slip-in	70 l/min [19 US gal/min]	210 bar [3000 psi]	CV - 18
	3C60-01	FC-144		70 l/min [19 US gal/min]	140 bar [2000 psi]	CV - 19
	3C80-01	FC-304		190 l/min [50 US gal/min]	140 bar [2000 psi]	CV - 20
	3C90-01	FC-304		190 l/min [50 US gal/min]	210 bar [3045 psi]	CV - 21

Symbol	Model No.	Cavity	Description	Flow*	Pressure	Page
	3C11-01	none	Check Valve, In-line, Female Port	20 l/min [5 US gal/min]	350 bar [5075 psi]	CV - 22
	RS 06	none		30 l/min [8 US gal/min]	350 bar [5075 psi]	CV - 23
	3C12-01	none		35 l/min [9 US gal/min]	350 bar [5075 psi]	CV - 24
	RS 10	none		60 l/min [16 US gal/min]	350 bar [5075 psi]	CV - 25
	3C13-01	none		70 l/min [19 US gal/min]	350 bar [5075 psi]	CV - 26
	3C14-01	none		95 l/min [25 US gal/min]	350 bar [5075 psi]	CV - 27
	RS 13	none		100 l/min [26 US gal/min]	315 bar [4500 psi]	CV - 28
	RS 19	none		140 l/min [37 US gal/min]	280 bar [4000 psi]	CV - 29
	3C15-01	none		150 l/min [40 US gal/min]	350 bar [5075 psi]	CV - 30
	RS 25	none		200 l/min [53 US gal/min]	245 bar [3500 psi]	CV - 31
	3C16-01	none		230 l/min [61 US gal/min]	350 bar [5075 psi]	CV - 32

\* Flow ratings are based on a pressure drop of 7 bar [100 psi] unless otherwise noted. They are for comparison purposes only.

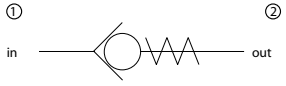
Symbol	Model No.	Cavity	Description	Flow*	Pressure	Page
	3CM11-01	none	Check Valve, In-line, Male Port	20 l/min [5 US gal/min]	350 bar [5075 psi]	CV - 33
	3CM12-01	none		35 l/min [9 US gal/min]	350 bar [5075 psi]	CV - 34
	3CM15-01	none		150 l/min [40 US gal/min]	350 bar [5075 psi]	CV - 35

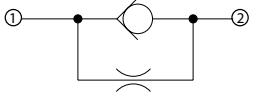
Symbol	Model No.	Cavity	Description	Flow*	Pressure	Page
	2RN11-01	none	Check Valve, In-line, Female Port, with Orifice	20 l/min [5 US gal/min]	350 bar [5075 psi]	CV - 36

\* Flow ratings are based on a pressure drop of 7 bar [100 psi] unless otherwise noted. They are for comparison purposes only.

**BASIC OPERATION**

Check valves allow free flow in one direction and block flow in the opposite direction.

Check valves



**STANDARD CHECK VALVES**

Standard check valves, suitable for most applications, have fully guided poppets which always block flow from 2 to 1. They are spring biased closed until sufficient pressure is applied at 1 to open flow to 2. This pressure is commonly called the crack pressure. Several crack pressures are available for each model. Consult check valves section for details. This valve is also available with an integral orifice for free flow in one direction and controlled flow (speed) in the opposite direction.

Standard check valve

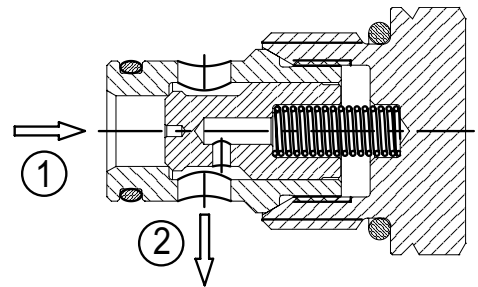

**REVERSE FLOW CHECK VALVES**

Reverse flow check valves, useful for higher pressure applications or where housing or size constraints require this flow path are also available. These valves have guided poppets that block flow from 1 to 2 and are spring biased closed until sufficient pressure is applied at 2 to open flow to 1.

Reverse flow check valve

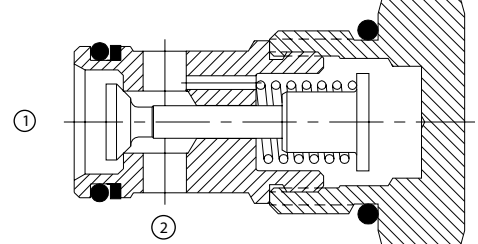

**SLIP-IN CHECK VALVES**

Slip-in style check valves are cartridges that drop into small cavities and are retained by SAE plugs or by other cartridge valves. They are ideal for use in manifolds where space savings is critical. Versions of these valves with Delrin® seats are also available for applications requiring extremely low leakage.

Slip-in check valve

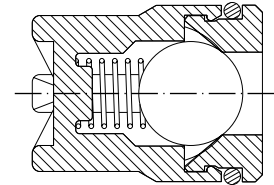

**INLINE CHECK VALVES**

Also available are in-line check valves, which can be used to simplify machine plumbing.

Inline check valve

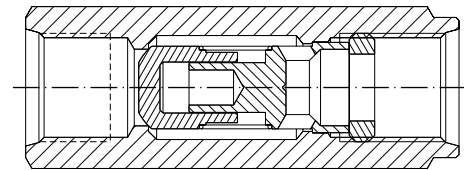

**APPLICATIONS**

Check valves have many common

applications including:

- Low pressure relief valve
- Bypass for filter elements
- Logic for load-sensing circuits
- Anti-cavitation or make-up
- Load holding (refer to Motion Control Valves for more information)

Low pressure relief valve

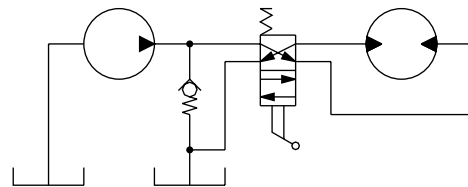

Bypass for filter elements

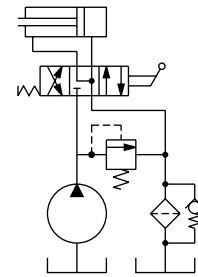

Logic for load-sensing circuits

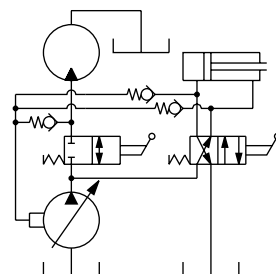

Anti-cavitation

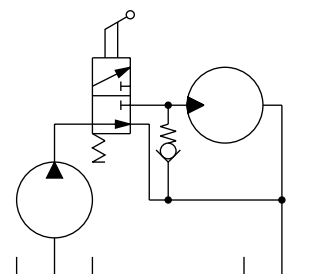

**OPERATION**

This valve allows free flow from 1 to 2 and blocks flow from 2 to 1.

**SPECIFICATIONS**

Theoretical performance

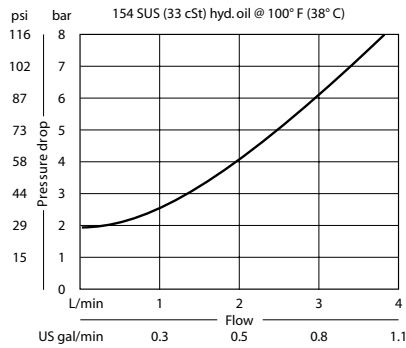

Schematic



Specifications

Rated pressure	207 bar [3000 psi]
Rated flow at 7 bar 100 psi	3 l/min [0.8 US gal/min]
Leakage	6 drops/min @ Rated pressure
Weight	0.01 kg [0.022 lb]
Cavity	CP04-2

**DIMENSIONS**

mm in

Cross-sectional view

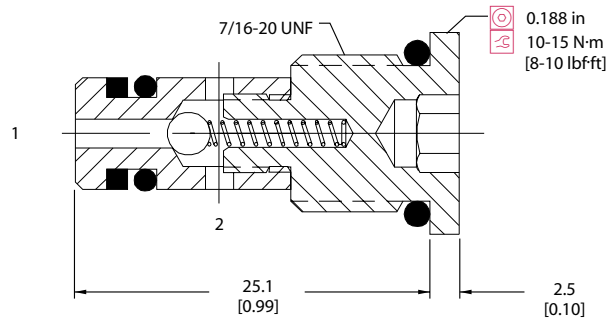

**ORDERING INFORMATION**

**CV04-NB-0.3-B-00**

Crack Pressure  
 0.3 = 0.3 bar [5 psi]  
 1.7 = 1.7 bar [25 psi]

Housing and ports  
 00 = No Housing  
 4S = Al, #4 SAE  
 2B = Al, 1/4 BSP

Housing Part #  
 No Housing  
 CP04-2-4S  
 CP04-2-2B

Seals  
 B = Buna-N  
 V = Viton

Seal Kit  
 120077  
 11019554

**OPERATION**

This valve allows free flow from 1 to 2 and blocks flow from 2 to 1.

**SPECIFICATIONS**

Theoretical performance

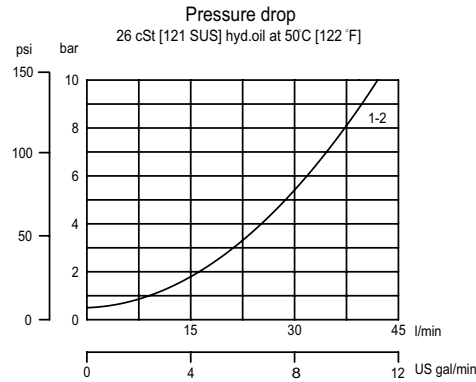

Schematic



Specifications

Rated pressure*	350 bar [5075 psi]
Rated flow at 7 bar [100 psi]	38 l/min [10 US gal/min]
Leakage	6 drops/min @ Rated pressure
Weight	0.05 kg [0.11 lb]
Cavity	SDC08-2

\*Rated pressure based on NFPA fatigue test standard (at 1 million cycles)

**DIMENSIONS**

mm in

Cross-sectional view

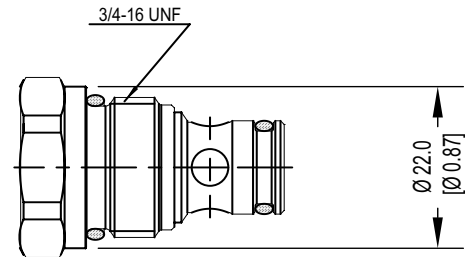
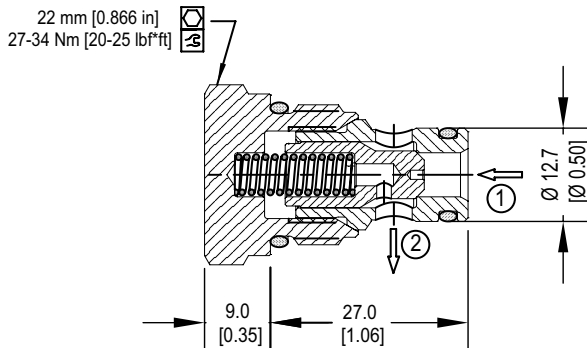

**ORDERING INFORMATION**

CV08-NP-0.3-B-00

Check Valve  
 Poppet Type, Normal Direction

Crack Pressure	
0.3	0.3 bar [5 psi]
1	1.0 bar [15 psi]
2	2.0 bar [30 psi]
5	5.0 bar [73 psi]
7	7.0 bar [100 psi]

Code	Ports & Material	Body Nomenclature
00	00 = Cartridge only	No Body
DG2B	Al, 1/4 BSP	SDC08-2-DG-2B
DG3B	Al, 3/8 BSP	SDC08-2-DG-3B
4S	Al, #4 SAE	CP08-2-4S
6S	Al, #6 SAE	CP08-2-6S

\*\*Aluminum bodies are to be used for pressures less than 210 bar (3000 psi)  
 \*\*\*Other housings available

Seal Option	Seal Kit
B = Buna-N	120221
V = Viton	120222



**OPERATION**

This valve allows free flow from 1 to 2 and blocks flow from 2 to 1.

**SPECIFICATIONS**

Theoretical performance

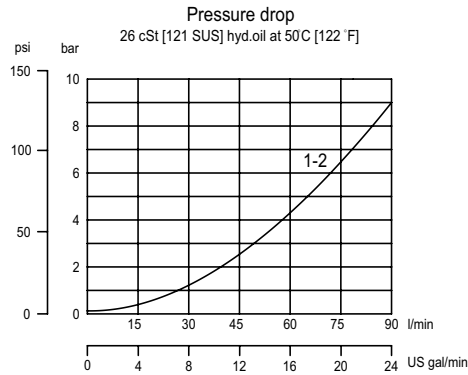

Schematic



Specifications

Rated pressure*	350 bar [5075 psi]
Rated flow at 7 bar [100 psi]	80 l/min [21.1 US gal/min]
Leakage	6 drops/min @ Rated pressure
Weight	0.08 kg [0.18 lb]
Cavity	SDC10-2

\*Rated pressure based on NFPA fatigue test standard (at 1 million cycles)

**DIMENSIONS**

mm in

Cross-sectional view

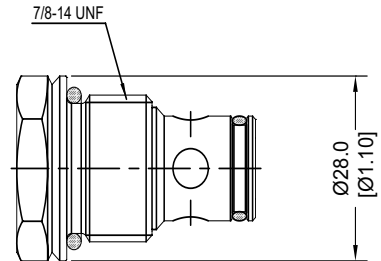
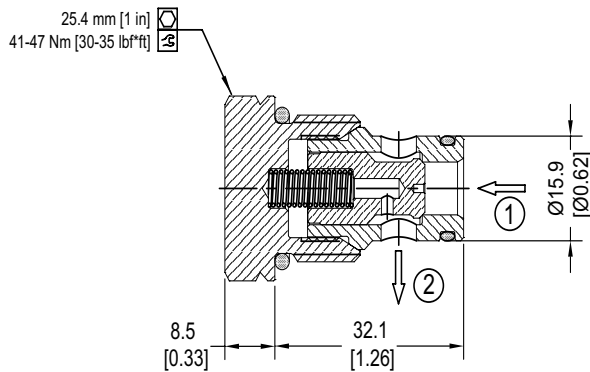

**ORDERING INFORMATION**

CV10-NP-0.3-B-00

Check Valve  
 Poppet Type, Normal Direction

Crack Pressure	
0.3	0.3 bar [5 psi]
1	1.0 bar [15 psi]
2	2.0 bar [30 psi]
5	5.0 bar [73 psi]
7	7.0 bar [100 psi]
10	10 bar [150 psi]
15	15 bar [217 psi]

Code	Ports & Material	Body Nomenclature
00	00 = Cartridge only	No Body
6S	Aluminum, #6 SAE	SDC10-2-6S
8S	Aluminum, #8 SAE	SDC10-2-8S
3B	Aluminum, 3/8 BSP	SDC10-2-3B
4B	Aluminum, 1/2 BSP	SDC10-2-4B

\*\*Aluminum bodies are to be used for pressures less than 210 bar (3000 psi)  
 \*\*\*Other housings available

Seal Option	Seal Kit
B = Buna-N	120015
V = Viton	120016

**OPERATION**

This valve allows free flow from 1 to 2 and blocks flow from 2 to 1.

**SPECIFICATIONS**

Theoretical performance

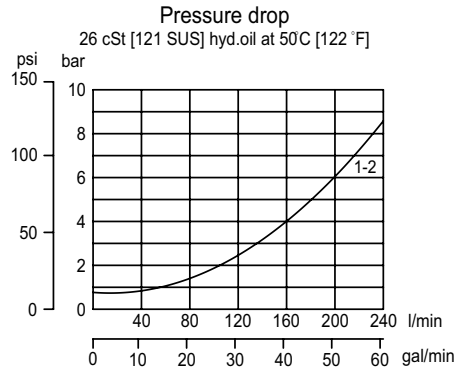

Schematic



Specifications

Rated pressure*	315 bar [4570 psi]
Rated flow at 7 bar [100 psi]	210 l/min [55.5 US gal/min]
Leakage	6 drops/min @ Rated pressure
Weight	0.26 kg [0.57 lb]
Cavity	SDC16-2

\*Rated pressure based on NFPA fatigue test standard (at 1 million cycles)

**DIMENSIONS**

mm in

Cross-sectional view

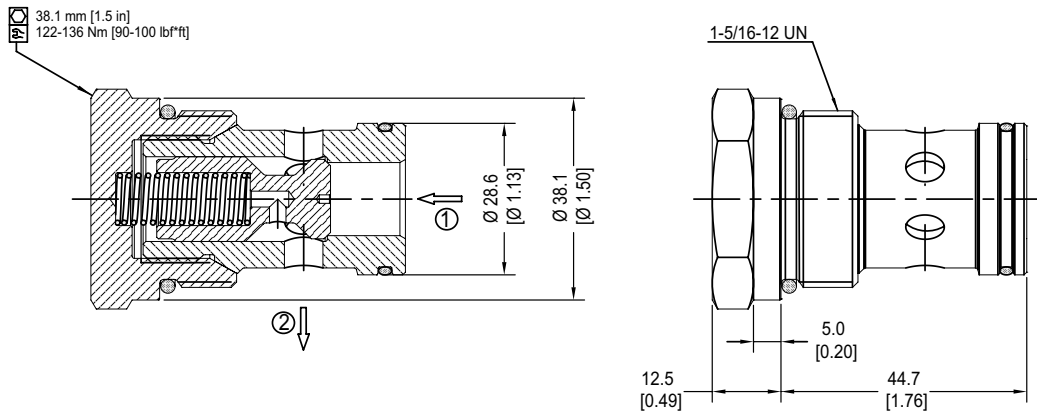

**ORDERING INFORMATION**

**CP102-1-B-0-005**

Check Valve  
Poppet Type, Normal Direction

Seal Kit	Seal Option
120019	B = Buna-N
120020	V = Viton

Code	Ports & Material	Body Nomenclature
0	0 = Cartridge only	No Body
DG6B	Al, 3/4 BSP	SDC16-2-DG-6B
DG8B	Al, 1 BSP	SDC16-2-DG-8B
12S	Al, #12 SAE	CP16-2-12S
16S	Al, #16 SAE	CP16-2-16S

Crack Pressure	
005	0.34 bar [5 psi]
015	1.0 bar [15 psi]
030	2.1 bar [30.4 psi]
040	2.8 bar [40 psi]
065	4.5 bar [65 psi]
100	6.9 bar [100 psi]

\*\*Aluminum bodies are to be used for pressures less than 210 bar (3000 psi)  
 \*\*\* Other housings available

CV - Check Valves Catalog  
CP102-1

**OPERATION**

This valve allows free flow from 1 to 2 and blocks flow from 2 to 1.

**SPECIFICATIONS**

Theoretical performance

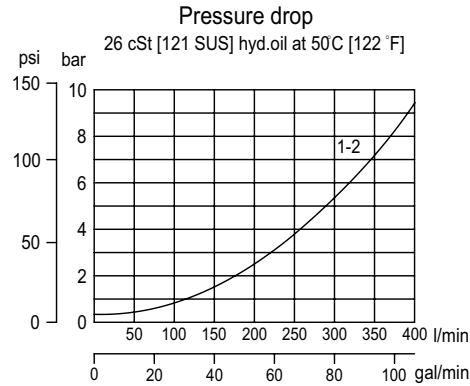

Schematic



Specifications

Rated pressure*	215 bar [3120 psi]
Rated flow at 7 bar [100 psi]	330 l/min [87.2 US gal/min]
Leakage	6 drops/min @ Rated pressure
Weight	0.54 kg [1.20 lb]
Cavity	SDC20-2

\*Rated pressure based on NFPA fatigue test standard (at 1 million cycles)

**DIMENSIONS**

mm in

Cross-sectional view

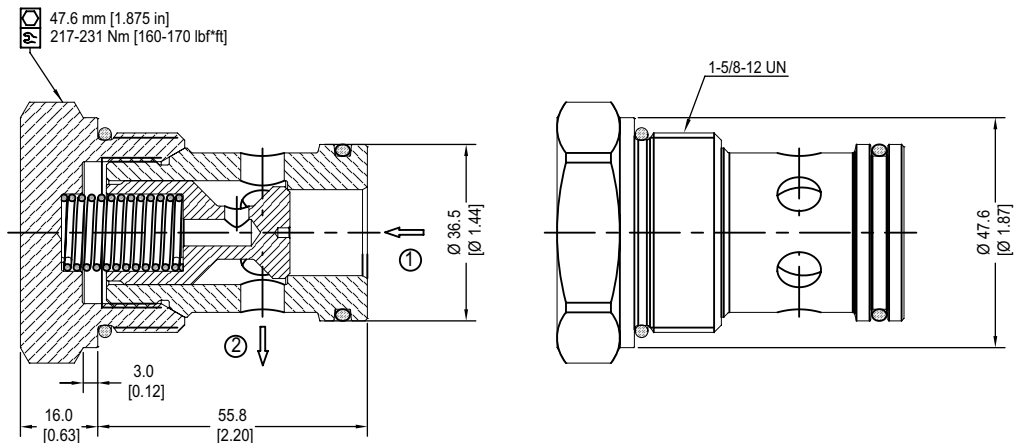

**ORDERING INFORMATION**

CP103-1-B-0-005

Check Valve  
 Poppet Type, Normal Direction

Seal Kit	Seal Option
120011	B = Buna-N
120012	V = Viton

Crack Pressure	Crack Pressure
005	0.34 bar [5 psi]
015	1.0 bar [15 psi]
030	2.1 bar [30 psi]
065	4.5 bar [65 psi]
100	7 bar [100 psi]

Code	Ports & Material	Body Nomenclature
0	0 = Cartridge only	No Body
8B	Al, 1 BSP	CP20-2-8B
10B	Al, 1-1/4 BSP	CP20-2-10B
16S	Al, #16 SAE	CP20-2-16S
20S	Al, #20 SAE	CP20-2-20S

\*\*Other housings available

**OPERATION**

This valve allows free flow from 2 to 1 and blocks flow from 1 to 2.

**SPECIFICATIONS**

Theoretical performance

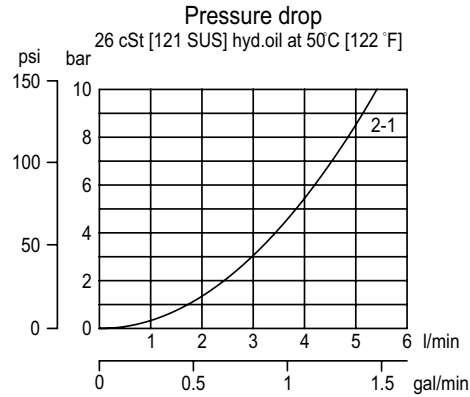

Schematic

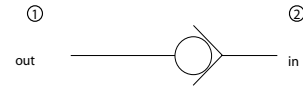

Specifications

Rated pressure*	350 bar [5075 psi]
Rated flow at 7 bar [100 psi]	4.5 l/min [1.2 US gal/min]
Leakage	6 drops/min @ Rated pressure
Weight	0.01 kg [0.022 lb]
Cavity	CP04-2

\*Rated pressure based on NFPA fatigue test standard (at 1 million cycles)

**DIMENSIONS**

mm in

Cross-sectional view

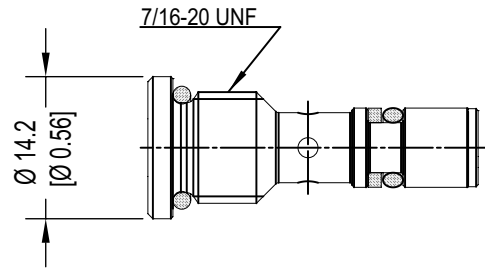
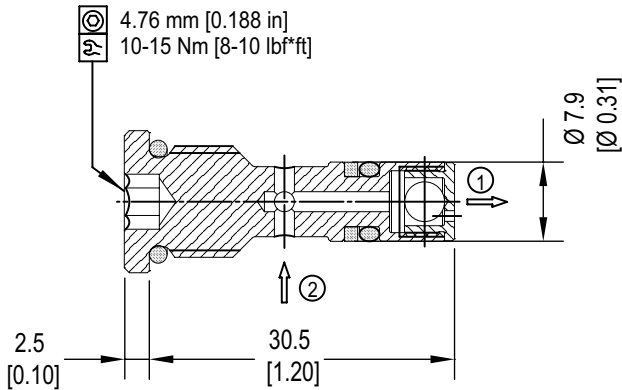

**ORDERING INFORMATION**

CP104-2-B-0

Check Valve  
 Ball Type, Reverse Direction

Seal Option	Seal kit
B = Buna-N	120077
V = Viton	11019554

Code	Ports & Material	Body Nomenclature
0	0 = Cartridge only	No Body
2B	Al, 1/4 BSP	CP04-3-2B
4S	Al, #4 SAE	CP04-2-4S

\*\*Aluminum bodies are to be used for pressures less than 210 bar (3000 psi)  
 \*\*\* Other housings available

**OPERATION**

This valve allows free flow from 2 to 1 and blocks flow from 1 to 2.

**SPECIFICATIONS**

Theoretical performance

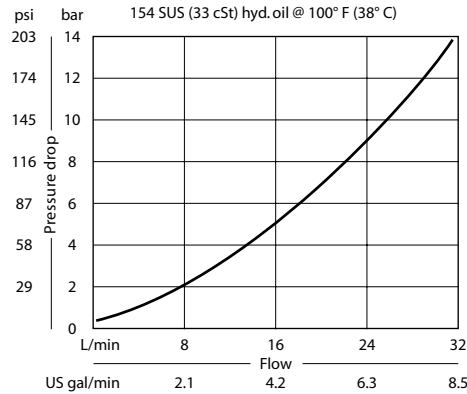

Schematic

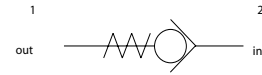

Specifications

Rated pressure	350 bar [5075 psi]
Rated flow at 7 bar [100 psi]	20 l/min [5 US gal/min]
Leakage	6 drops/min @ 207 bar 3000 psi
Weight	0.05 kg [0.11 lb]
Cavity	SDC08-2

**DIMENSIONS**

mm in

Cross-sectional view

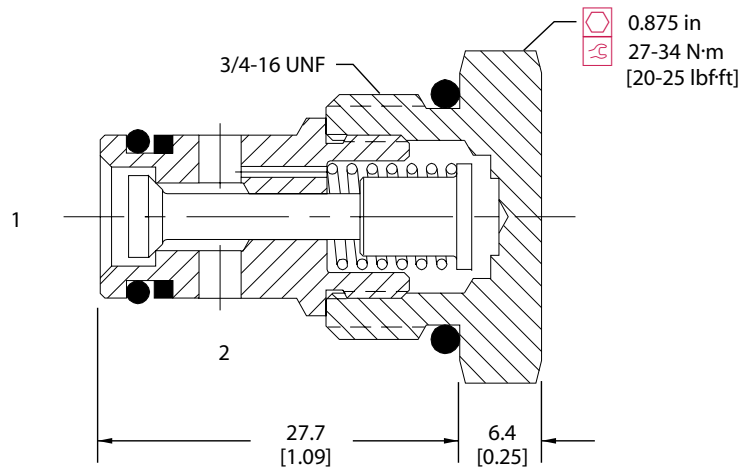

**ORDERING INFORMATION**

CP108-2-B-6S-005

**Housing and ports**

- 0 = No Housing
- DG2B = Al, 1/4 BSP
- DG3B = Al, 3/8 BSP
- 4S = Al, #4 SAE
- 6S = Al, #6 SAE
- Other housings available

**Housing P/N**

- No Housing
- SDC08-2-DG-2B
- SDC08-2-DG-3B
- CP8-2-4S
- CP8-2-6S

**Crack pressure**

- 005 = 0.34 bar [5 psi]
- 015 = 1.0 bar [15 psi]
- 030 = 2.1 bar [30 psi]
- 050 = 3.4 bar [50 psi]
- 065 = 4.5 bar [65 psi]
- 100 = 6.9 bar [100 psi]

**Seals**

- B = Buna-N 120221
- V = Viton 120222

**OPERATION**

This valve allows free flow from 2 to 1 and blocks flow from 1 to 2.

**SPECIFICATIONS**

**Theoretical performance**

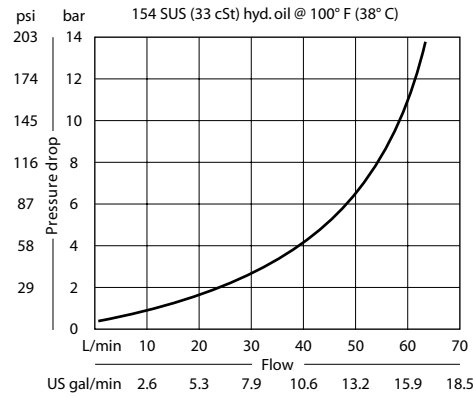

**Schematic**

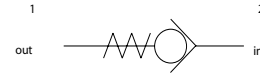

**Specifications**

Rated pressure	350 bar [5075 psi]
Rated flow at 7 bar [100 psi]	50 l/min [13 US gal/min]
Leakage	6 drops/min @ 207 bar 3000 psi
Weight	0.08 kg [0.17 lb]
Cavity	SDC10-2

**DIMENSIONS**

mm in

**Cross-sectional view**

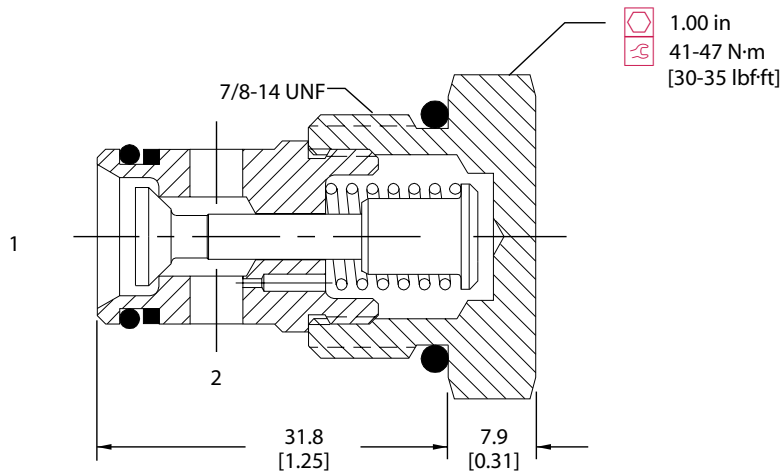

**ORDERING INFORMATION**

CP100-2-B-8S-005

**Housing and ports**

- 0 = No Housing
- DG3B = Al, 3/8 BSP
- DG4B = Al, 1/2 BSP
- 6S = Al, #6 SAE
- 8S = Al, #8 SAE
- Other housings available

**Housing P/N**

- No Housing
- SDC10-2-DG-3B
- SDC10-2-DG-4B
- CP10-2-6S
- CP10-2-8S

**Crack pressure**

- 005 = 0.34 bar [5 psi]
- 015 = 1.0 bar [15 psi]
- 030 = 2.1 bar [30 psi]
- 050 = 3.4 bar [50 psi]
- 065 = 4.5 bar [65 psi]
- 100 = 6.9 bar [100 psi]

**Seals**

- B = Buna-N
- V = Viton
- Seal kit 120015
- Seal kit 120016

**OPERATION**

This valve allows free flow from 2 to 1 and blocks flow from 1 to 2.

**SPECIFICATIONS**

**Theoretical performance**

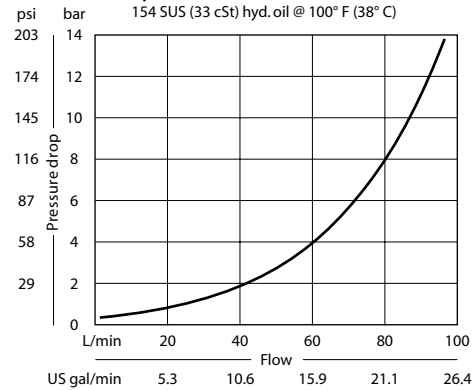

**Schematic**

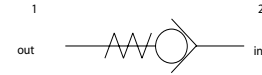

**Specifications**

Rated pressure	350 bar [5075 psi]
Rated flow at 7 bar	75 l/min
100 psi	[20 US gal/min]
Leakage	6 drops/min @ 207 bar 3000 psi
Weight	0.18 kg [0.40 lb]
Cavity	CP12-2

**DIMENSIONS**

mm in

**Cross-sectional view**

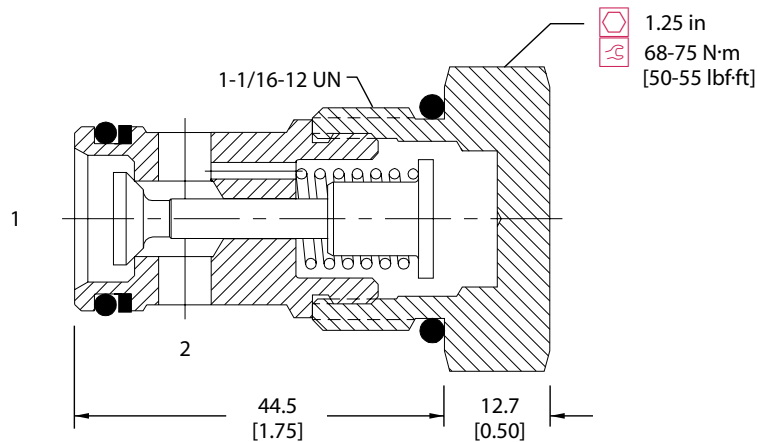

**ORDERING INFORMATION**

CP101-2-B-12S-005

**Housing and ports**

- 0 = No Housing
- 4B = Al, 1/2 BSP
- 6B = Al, 3/4 BSP
- 10S = Al, #10 SAE
- 12S = Al, #12 SAE
- Other housings available

**Housing P/N**

- No Housing
- CP12-2-4B
- CP12-2-6B
- CP12-2-10S
- CP12-2-12S

**Crack pressure**

- 005 = 0.34 bar [5 psi]
- 015 = 1.0 bar [15 psi]
- 030 = 2.1 bar [30 psi]
- 065 = 4.5 bar [65 psi]
- 100 = 6.9 bar [100 psi]

**Seals**

- B = Buna-N 120017
- V = Viton 120018

**Seal kit**

- 120017
- 120018

**OPERATION**

This valve allows free flow from 2 to 1 and blocks flow from 1 to 2.

**SPECIFICATIONS**

Theoretical performance

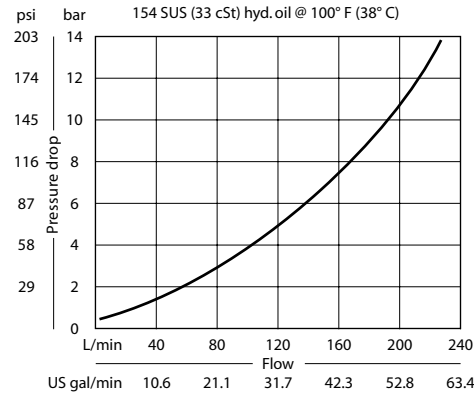

Schematic

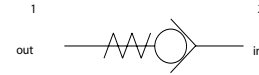

Specifications

Rated pressure	350 bar [5075 psi]
Rated flow at 7 bar	150 l/min
100 psi	[40 US gal/min]
Leakage	6 drops/min @ 207 bar 3000 psi
Weight	0.26 kg [0.57 lb]
Cavity	SDC16-2

**DIMENSIONS**

mm in

Cross-sectional view

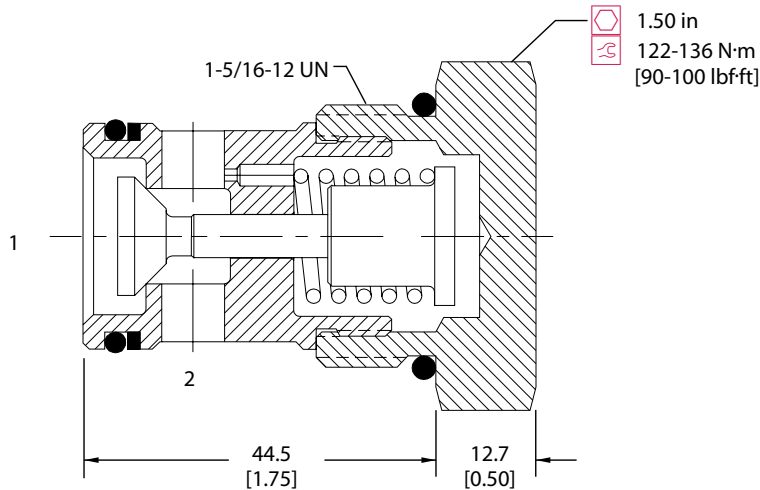

**ORDERING INFORMATION**

CP102-2-B-16S-005

**Housing and ports**  
 0 = No Housing  
 HG-6B = Al, 3/4 BSP  
 HG-8B = Al, 1 BSP  
 12S = Al, #12 SAE  
 16S = Al, #16 SAE  
 Other housings available

**Housing P/N**  
 No Housing  
 SDC16-2-HG-6B  
 SDC16-2-HG-8B  
 CP16-2-12S  
 CP16-2-16S

**Crack pressure**  
 005 = 0.34 bar [5 psi]  
 015 = 1.0 bar [15 psi]  
 030 = 2.1 bar [30 psi]  
 050 = 3.4 bar [50 psi]  
 065 = 4.5 bar [65 psi]  
 100 = 6.9 bar [100 psi]

**Seals**  
 B = Buna-N 120019  
 V = Viton 120020

CV - Check Valves Catalog  
 CP102-2



**OPERATION**

This valve allows free flow from 2 to 1 and blocks flow from 1 to 2.

**SPECIFICATIONS**

Theoretical performance

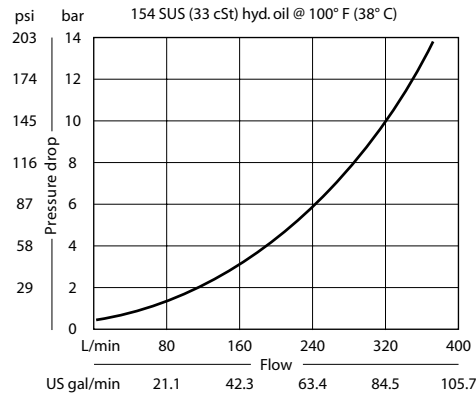

Schematic

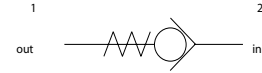

Specifications

Rated pressure	350 bar [5075 psi]
Rated flow at 7 bar	265 l/min
100 psi	[70 US gal/min]
Leakage	6 drops/min @ 207 bar 3000 psi
Weight	0.54 kg [1.20 lb]
Cavity	SDC20-2

**DIMENSIONS**

mm in

Cross-sectional view

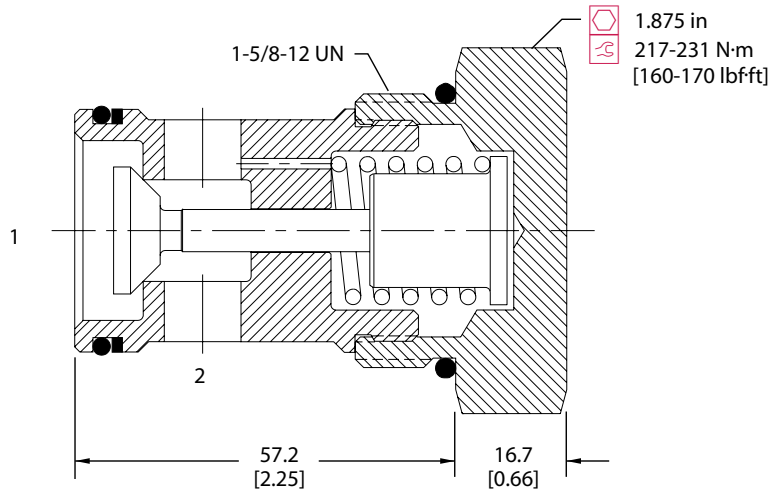

**ORDERING INFORMATION**

CP103-2-B-20S-005

**Housing and ports**

- 0 = No Housing
  - 8B = Al, 1 BSP
  - 10B = Al, 1-1/4 BSP
  - 16S = Al, #16 SAE
  - 20S = Al, #20 SAE
- Other housings available

**Housing P/N**

- No Housing
- CP20-2-8B
- CP20-2-10B
- CP20-2-16S
- CP20-2-20S

**Crack pressure**

- 005 = 0.34 bar [5 psi]
- 015 = 1.0 bar [15 psi]
- 030 = 2.1 bar [30 psi]
- 050 = 3.4 bar [50 psi]
- 065 = 4.5 bar [65 psi]
- 100 = 6.9 bar [100 psi]

**Seals**

- |            |          |
|------------|----------|
| Code       | Seal kit |
| B = Buna-N | 120011   |
| V = Viton  | 120012   |

**OPERATION**

This valve allows free flow from 1 to 2 and blocks flow from 2 to 1.

**SPECIFICATIONS**

Theoretical performance

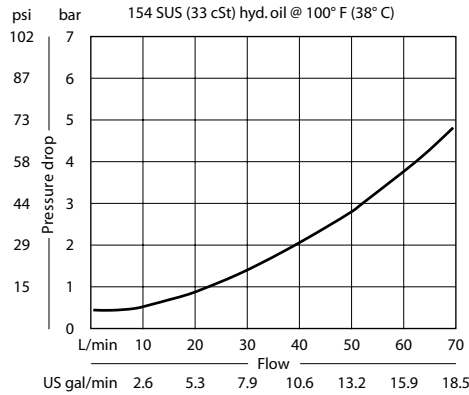

Schematic



Specifications

Rated pressure	210 bar [3045 psi]
Rated flow at 7 bar	70 l/min
100 psi	[19 US gal/min]
Leakage	15 drops/min @ rated pressure
Weight	0.03 kg [0.07 lb]
Cavity	FC-144

**DIMENSIONS**

mm in

Cross-sectional view

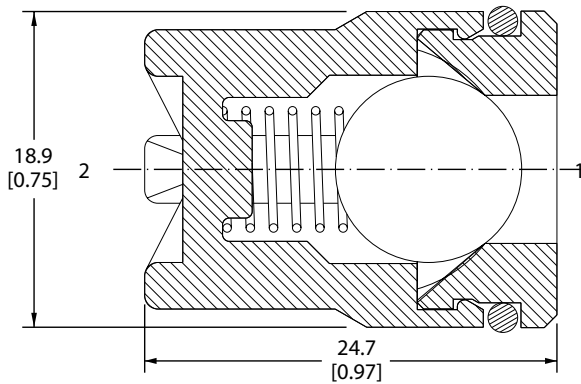

**ORDERING INFORMATION**

3C50-01-B-0-005

**Crack pressure**  
 005 = 0.34 bar [5 psi]

**Housing and ports**  
 0 = No Housing

**Seals**

B = Buna-N	Seal kit 720399
V = Viton	720420

**OPERATION**

This valve allows free flow from 1 to 2 and blocks flow from 2 to 1. Valve uses a Delrin® seat for low leakage

**SPECIFICATIONS**

Theoretical performance

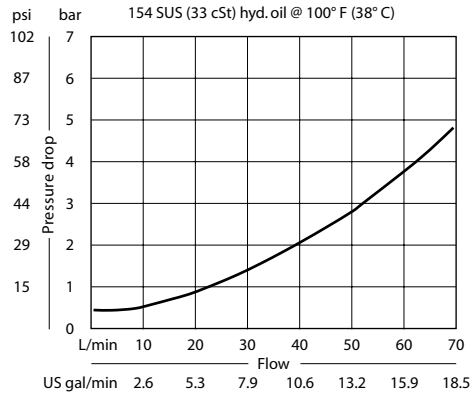

Schematic



Specifications

Rated pressure	140 bar [2000 psi]
Rated flow at 7 bar 100 psi	70 l/min [19 US gal/min]
Leakage	6 drops/min @ rated pressure
Weight	0.01 kg [0.02 lb]
Cavity	FC-144

**DIMENSIONS**

mm in

Cross-sectional view

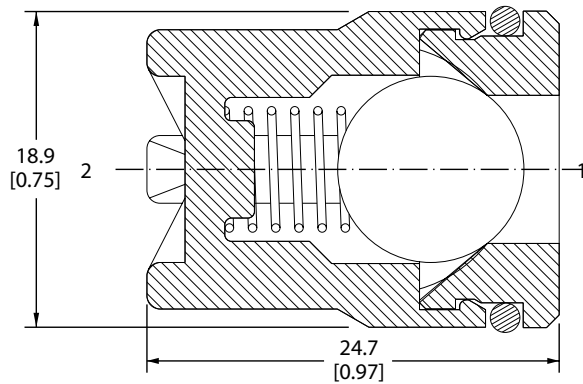

**ORDERING INFORMATION**

3C60-01-B-0-005

**Crack pressure**  
 005 = 0.34 bar [5 psi]

**Housing and ports**  
 0 = No Housing

**Seals**  
 B = Buna-N  
 V = Viton

Seal kit  
 720399  
 720420

**OPERATION**

This valve allows free flow from 1 to 2 and blocks flow from 2 to 1. Valve uses a Delrin® seat for low leakage.

**SPECIFICATIONS**

Theoretical performance

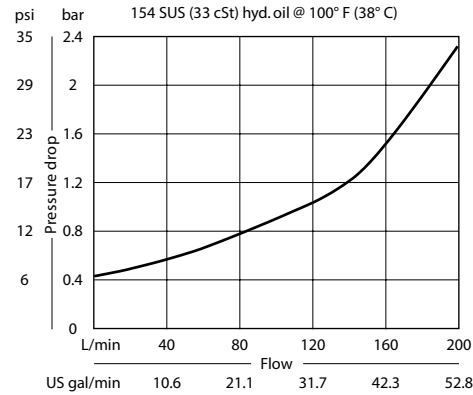

Schematic



Specifications

Rated pressure	140 bar [2000 psi]
Rated flow at 7 bar	190 l/min
100 psi	[50 US gal/min]
Leakage	6 drops/min @ rated pressure
Weight	0.04 kg [0.09 lb]
Cavity	FC-304

**DIMENSIONS**

mm in

Cross-sectional view

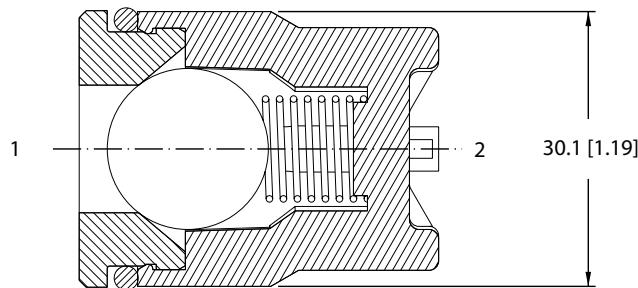

**ORDERING INFORMATION**

3C80-01-B-0-005

**Cracking pressure**  
 005 = 0.34 bar [5 psi]  
 025 = 1.7 bar [25 psi]

**Housing and ports**  
 00 = No Housing

**Seals**

B = Buna-N Seal kit 720607  
 V = Viton Seal kit 720601

P102 554E

**OPERATION**

This valve allows free flow from 1 to 2 and blocks flow from 2 to 1.

**SPECIFICATIONS**

Theoretical performance

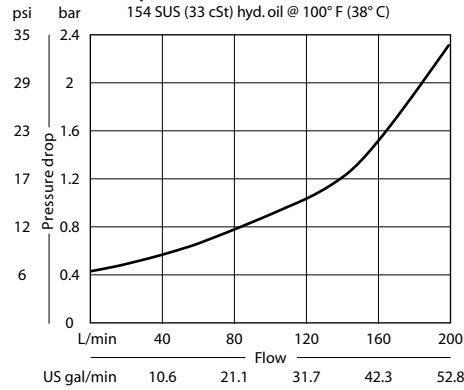

Schematic



Specifications

Rated pressure	210 bar [3045 psi]
Rated flow at 7 bar	190 l/min
100 psi	[50 US gal/min]
Leakage	15 drops/min @ rated pressure
Weight	0.05 kg [0.11 lb]
Cavity	FC-304

**DIMENSIONS**

mm in

Cross-sectional view

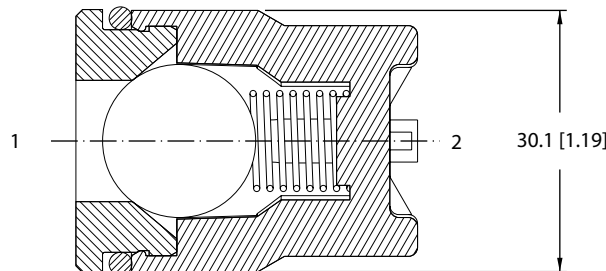

**ORDERING INFORMATION**

3C90-01-B-0-005

**Crack pressure**  
 005 = 0.34 bar [5 psi]

**Housing and ports**  
 0 = No Housing

**Seals**

Seal kit  
 B = Buna-N 720607  
 V = Viton 720601

**OPERATION**

This valve allows free flow from 1 to 2 and blocks flow from 2 to 1.

**SPECIFICATIONS**

Theoretical performance

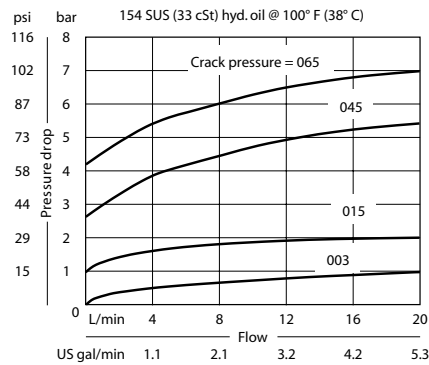

Schematic



Specifications

Rated pressure	350 bar [5075 psi]
Rated flow at 7 bar	20 l/min
100 psi	[5 US gal/min]
Leakage	5 drops/min @ Rated pressure
Weight	0.11 kg [0.24 lb]
Cavity	none

**DIMENSIONS**

mm in

Cross-sectional view

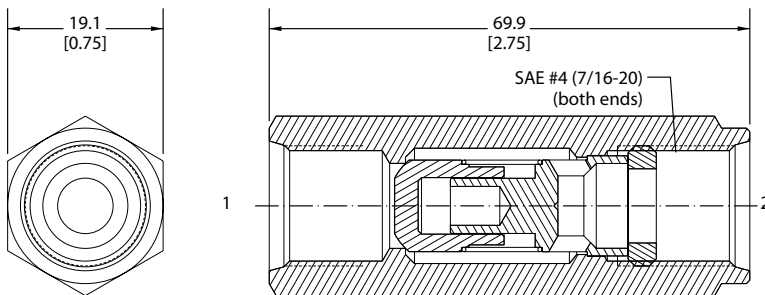

**ORDERING INFORMATION**

3C11-01-4S-65

**Crack pressure**  
 3 = 0.2 bar [3 psi]  
 15 = 1.0 bar [15 psi]  
 45 = 3.1 bar [45 psi]  
 65 = 4.5 bar [65 psi]

**Port sizes**  
 4S = SAE #4

**OPERATION**

This valve allows free flow from 1 to 2 and blocks flow from 2 to 1.

**SPECIFICATIONS**

Theoretical performance

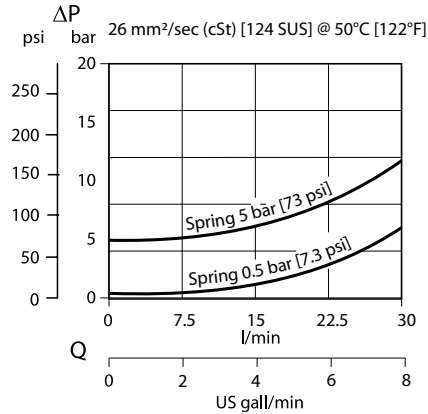

Schematic



Specifications

Rated pressure	350 bar [5075 psi]
Rated flow at 7 bar	30 l/min
100 psi	[8 US gal/min]
Weight	0.08 kg [0.18 lb]
Cavity	none

**DIMENSIONS**

mm in

Cross-sectional view

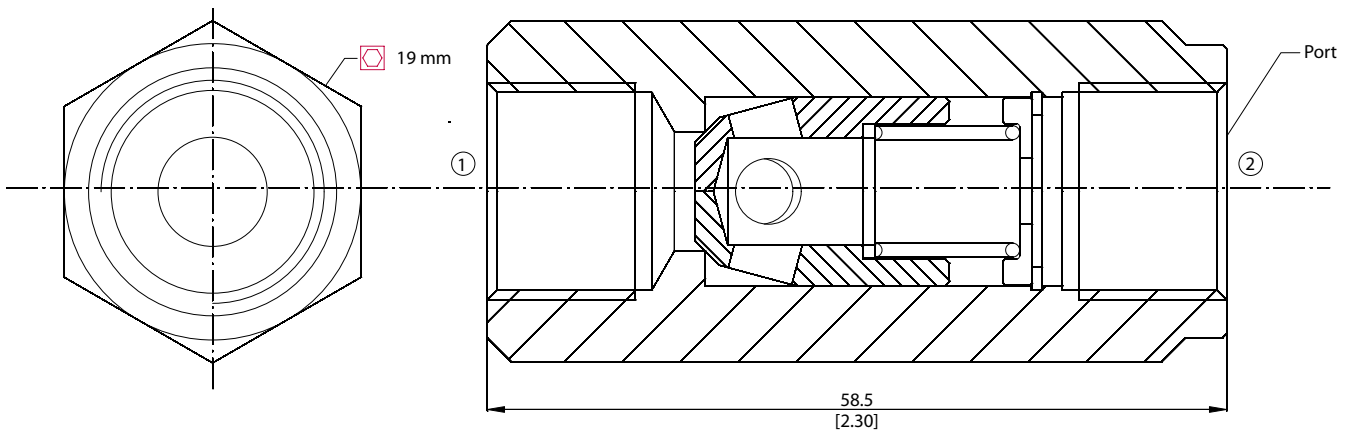

**ORDERING INFORMATION**

RS 06 / 0.5 G

**Port**

A = SAE #6  
 G = 1/4 BSP

**Crack pressure**

0.5 = 0.5 bar [7.25 psi]  
 5 = 5 bar [72.5 psi]

**OPERATION**

This valve allows free flow from 1 to 2 and blocks flow from 2 to 1.

**SPECIFICATIONS**

Theoretical performance

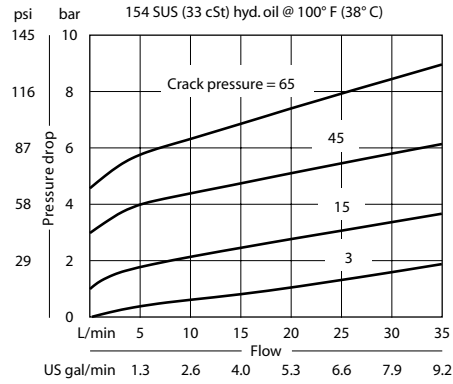

Schematic



Specifications

Rated pressure	350 bar [5075 psi]
Rated flow at 7 bar 100 psi	35 l/min [9 US gal/min]
Leakage	5 drops/min @ Rated pressure
Weight	0.17 kg [0.37 lb]
Cavity	none

**DIMENSIONS**

mm in

Cross-sectional view

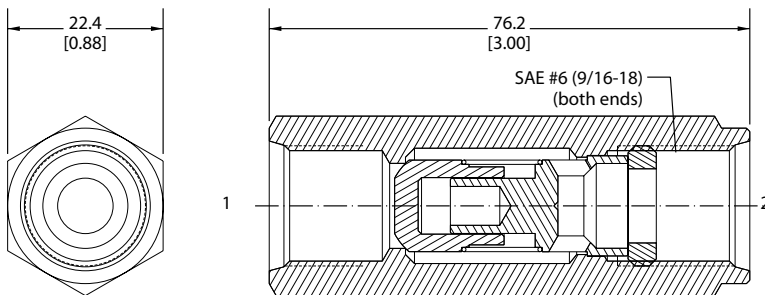

**ORDERING INFORMATION**

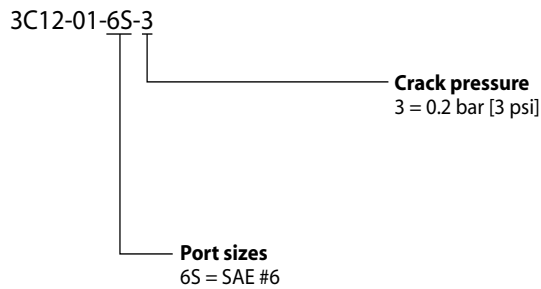

CV - Check Valves Catalog  
 3C12-01



**OPERATION**

This valve allows free flow from 1 to 2 and blocks flow from 2 to 1.

**SPECIFICATIONS**

Theoretical performance

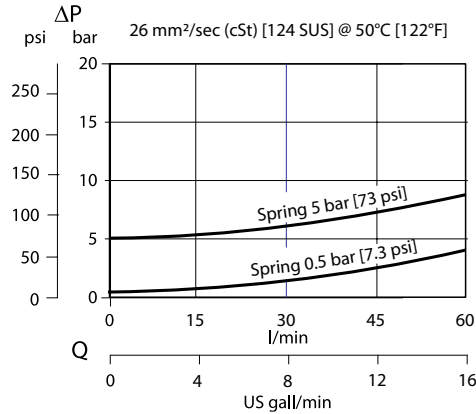

Schematic



Specifications

Rated pressure	350 bar [5075 psi]
Rated flow at 7 bar	60 l/min
100 psi	[16 US gal/min]
Weight	0.13 kg [0.29 lb]
Cavity	none

**DIMENSIONS**

mm in

Cross-sectional view

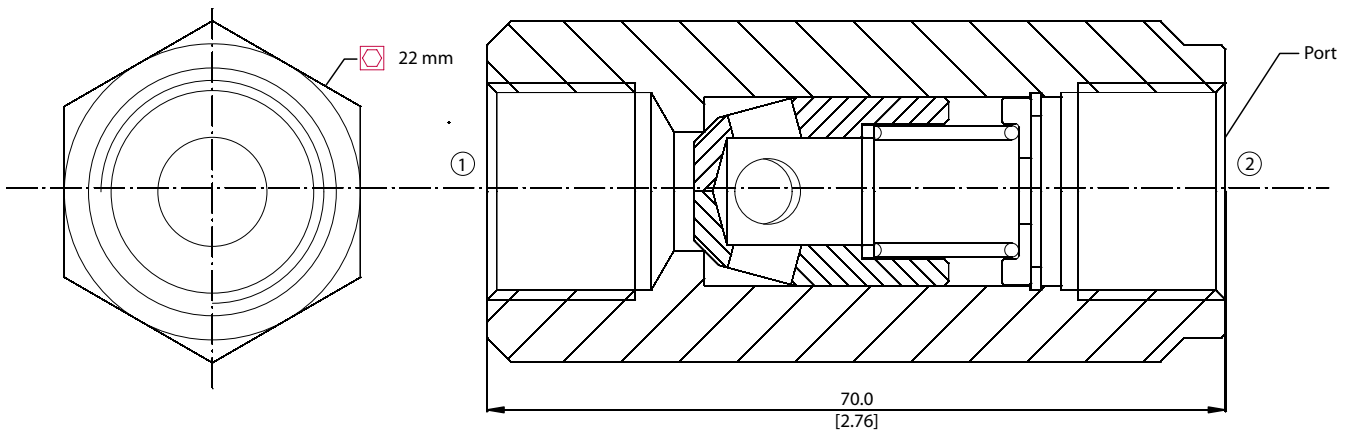

**ORDERING INFORMATION**

**RS 10 / 5 - G**



**Crack Pressure**  
 0.5 = 0.5 bar [7 psi]  
 5 = 5 bar [73 psi]

**OPERATION**

This valve allows free flow from 1 to 2 and blocks flow from 2 to 1.

**SPECIFICATIONS**

**Theoretical performance**

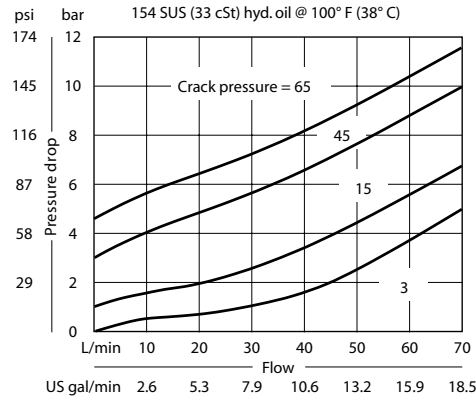

**Schematic**



**Specifications**

Rated pressure	350 bar [5075 psi]
Rated flow at 7 bar 100 psi	70 l/min [19 US gal/min]
Leakage	5 drops/min @ Rated pressure
Weight	0.31 kg [0.68 lb]
Cavity	none

**DIMENSIONS**

mm in

**Cross-sectional view**

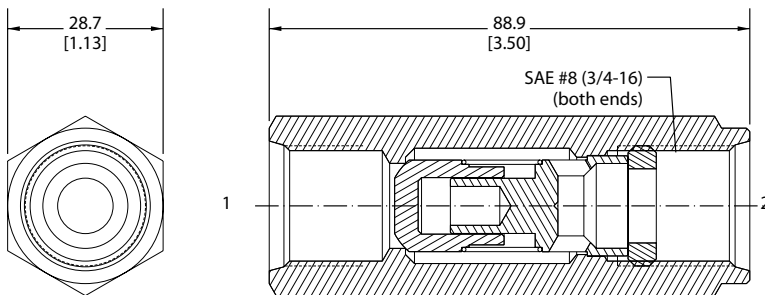

**ORDERING INFORMATION**

3C13-01-8S-3

**Crack pressure**

- 3 = 0.2 bar [3 psi]
- 15 = 1.0 bar [15 psi]
- 45 = 3.1 bar [45 psi]
- 65 = 4.5 bar [65 psi]

**Port sizes**

8S = SAE #8

CV - Check Valves Catalog  
3C13-01

**OPERATION**

This valve allows free flow from 1 to 2 and blocks flow from 2 to 1.

**SPECIFICATIONS**

Theoretical performance

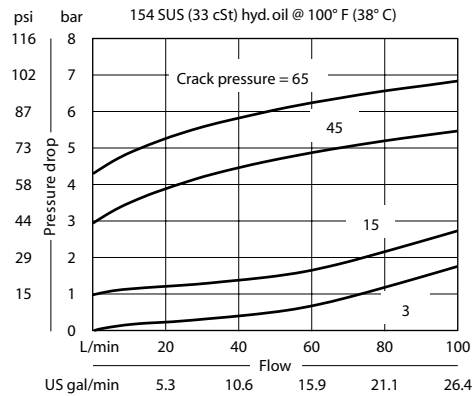

Schematic



Specifications

Rated pressure	350 bar [5075 psi]
Rated flow at 7 bar	95 l/min
100 psi	[25 US gal/min]
Leakage	5 drops/min @ Rated pressure
Weight	0.54 kg [1.19 lb]
Cavity	none

**DIMENSIONS**

mm in

Cross-sectional view

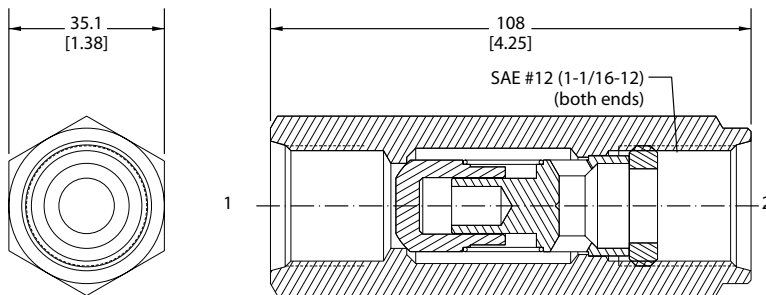

**ORDERING INFORMATION**

3C14-01-12S-3

**Crack pressure**  
 3 = 0.2 bar [3 psi]  
 15 = 1.0 bar [15 psi]  
 45 = 3.1 bar [45 psi]  
 65 = 4.5 bar [65 psi]

**Port sizes**  
 12S = SAE #12

**OPERATION**

This valve allows free flow from 1 to 2 and blocks flow from 2 to 1.

**SPECIFICATIONS**

Theoretical performance

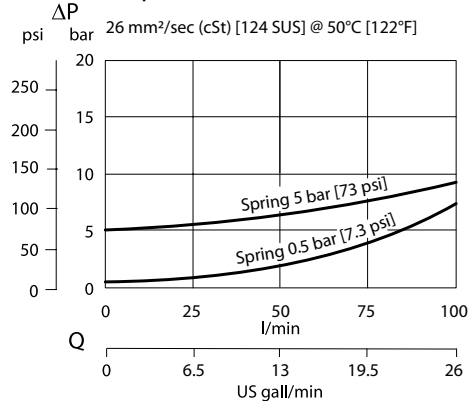

Schematic



Specifications

Rated pressure	315 bar [4500 psi]
Rated flow at 7 bar	100 l/min
100 psi	[26 US gal/min]
Weight	0.21 kg [0.46 lb]
Cavity	none

**DIMENSIONS**

mm in

Cross-sectional view

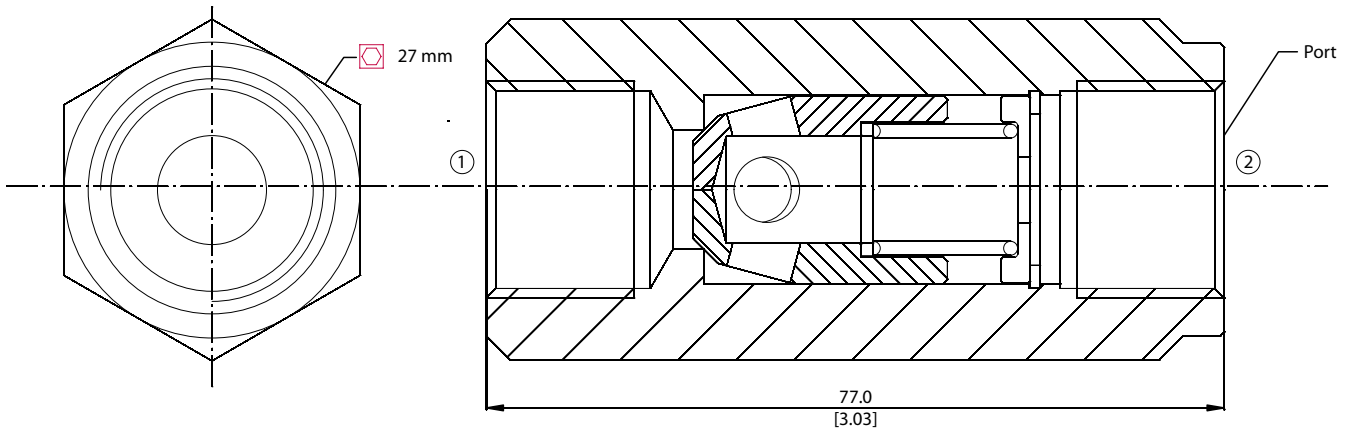

**ORDERING INFORMATION**

**RS 13 / 0.5 - G**

**Ports**  
 G = 1/2 BSP

**Crack Pressure**  
 0.5 = 0.5 bar [7 psi]  
 5 = 5 bar [73 psi]

**OPERATION**

This valve allows free flow from 1 to 2 and blocks flow from 2 to 1.

**SPECIFICATIONS**

Theoretical performance

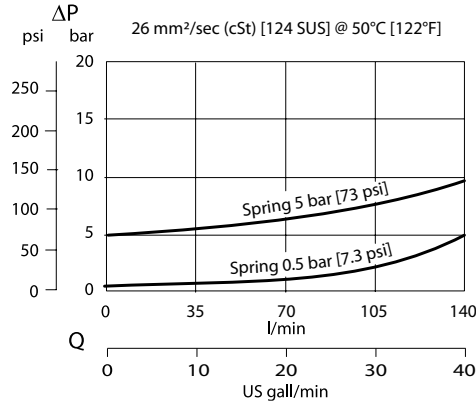

Schematic



Specifications

Rated pressure	280 bar [4000 psi]
Rated flow at 7 bar	140 l/min
100 psi	[37 US gal/min]
Weight	0.43 kg [0.95 lb]
Cavity	none

**DIMENSIONS**

mm in

Cross-sectional view

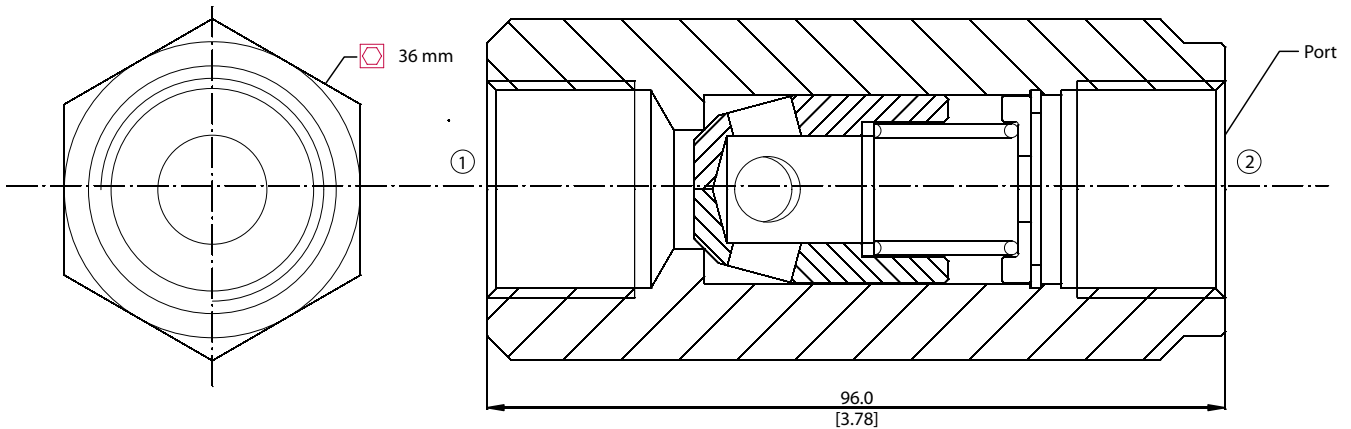

**ORDERING INFORMATION**

**RS 19 / 0.5 - G**

**Ports**

A = SAE #12  
 G = 3/4 BSP

**Crack Pressure**

0.5 = 0.5 bar [7 psi]  
 5 = 5 bar [73 psi]

**OPERATION**

This valve allows free flow from 1 to 2 and blocks flow from 2 to 1.

**SPECIFICATIONS**

**Theoretical performance**

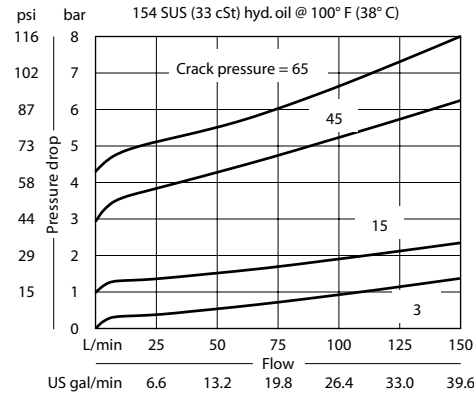

**Schematic**



**Specifications**

Rated pressure	350 bar [5075 psi]
Rated flow at 7 bar	150 l/min
100 psi	[40 US gal/min]
Leakage	5 drops/min @ Rated pressure
Weight	1.00 kg [2.20 lb]
Cavity	none

**DIMENSIONS**

mm in

**Cross-sectional view**

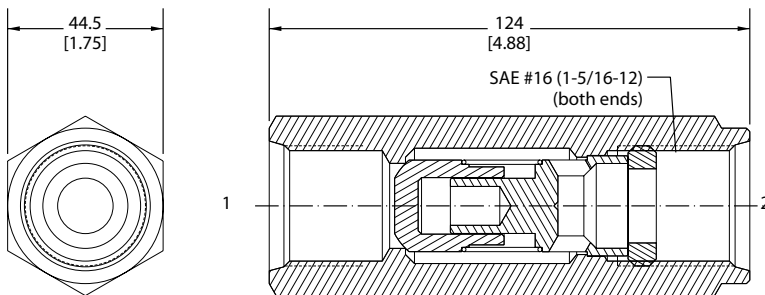

**ORDERING INFORMATION**

3C15-01-16S-45

**Crack pressure**

3 = 0.2 bar [3 psi]  
 15 = 1.0 bar [15 psi]  
 45 = 3.1 bar [45 psi]  
 65 = 4.5 bar [65 psi]

**Port sizes**

16S = SAE #16

**OPERATION**

This valve allows free flow from 1 to 2 and blocks flow from 2 to 1.

**SPECIFICATIONS**

Theoretical performance

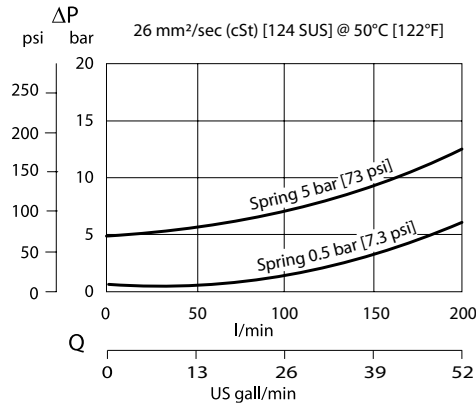

Schematic



Specifications

Rated pressure	245 bar [3500 psi]
Rated flow at 7 bar	200 l/min
100 psi	[53 US gal/min]
Weight	0.88 kg [1.94 lb]
Cavity	none

**DIMENSIONS**

mm in

Cross-sectional view

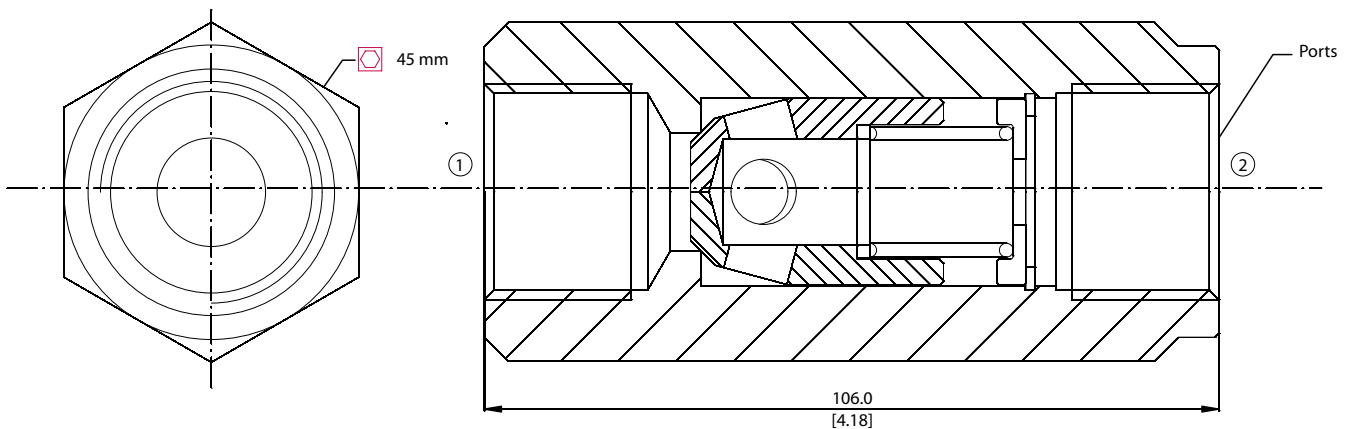

**ORDERING INFORMATION**

**RS 25 / 0.5 - G**

**Ports**  
 A = SAE #16  
 G=1 BSP

**Crack Pressure**  
 0.5 = 0.5 bar [7 psi]  
 5 = 5 bar [73 psi]

CV - Check Valves Catalog  
 RS 25

**OPERATION**

This valve allows free flow from 1 to 2 and blocks flow from 2 to 1.

**SPECIFICATIONS**

**Theoretical performance**

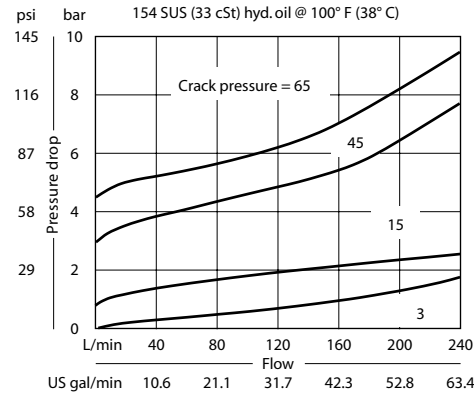

**Schematic**



**Specifications**

Rated pressure	350 bar [5075 psi]
Rated flow at 7 bar	230 l/min
100 psi	[61 US gal/min]
Leakage	5 drops/min @ Rated pressure
Weight	1.91 kg [4.21 lb]
Cavity	none

**DIMENSIONS**

mm in

**Cross-sectional view**

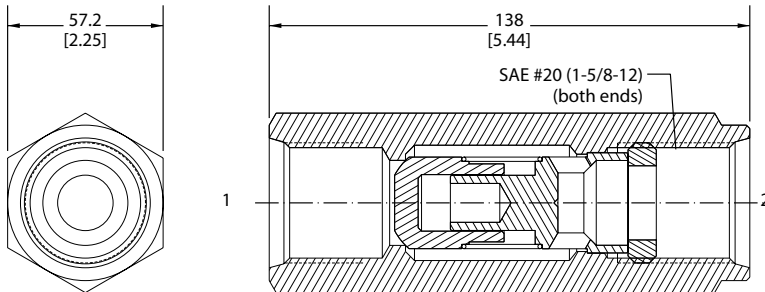

**ORDERING INFORMATION**

3C16-01-20S-3

**Crack pressure**  
 3 = 0.2 bar [3 psi]  
 15 = 1.0 bar [15 psi]  
 45 = 3.1 bar [45 psi]  
 65 = 4.5 bar [65 psi]

**Port sizes**  
 20S = SAE #20

CV - Check Valves Catalog  
 3C16-01



**OPERATION**

This valve allows free flow from 1 to 2 and blocks flow from 2 to 1.

**SPECIFICATIONS**

Theoretical performance

Schematic

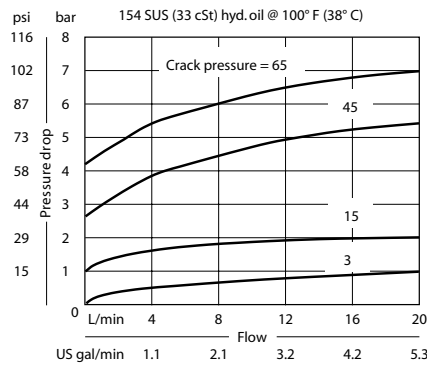

**Specifications**

Rated pressure	350 bar [5075 psi]
Rated flow at 7 bar	20 l/min
100 psi	[5 US gal/min]
Leakage	5 drops/min @ Rated pressure
Weight	0.09 kg [0.20 lb]
Cavity	none

**DIMENSIONS**

mm in

Cross-sectional view

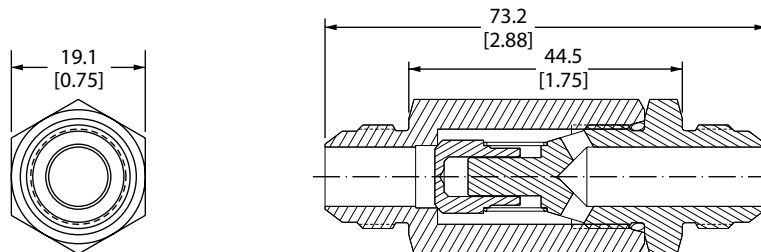

**ORDERING INFORMATION**

3CM11-01-B-6F-6F-03

**Guide port**  
 6F = SAE #6, 37° flare

**Body port**  
 6F = SAE #6, 37° flare

**Seals**  
 B = Buna-N  
 V = Viton

**Seal kit**  
 720063  
 720064

**Crack pressure**  
 3 = 0.2 bar [3 psi]  
 15 = 1.0 bar [15 psi]  
 45 = 3.1 bar [45 psi]  
 65 = 4.5 bar [65 psi]

**OPERATION**

This valve allows free flow from 1 to 2 and blocks flow from 2 to 1.

**SPECIFICATIONS**

Theoretical performance

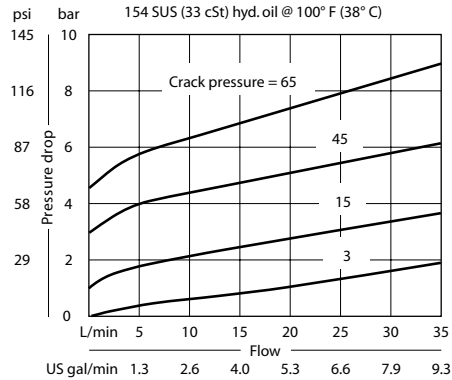

Schematic



Specifications

Rated pressure	350 bar [5075 psi]
Rated flow at 7 bar 100 psi	35 l/min [9 US gal/min]
Leakage	5 drops/min @ Rated pressure
Weight	0.23 kg [0.51 lb]
Cavity	none

**DIMENSIONS**

mm in

Cross-sectional view

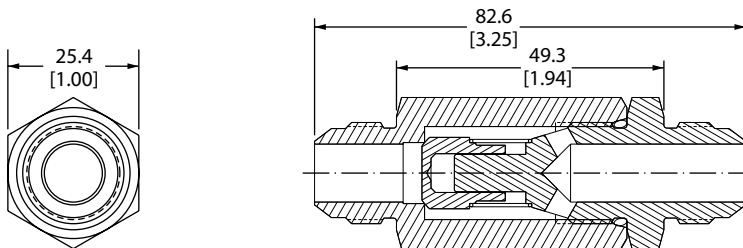

P102 595

**ORDERING INFORMATION**

3CM12-01-B-8F-8F-03

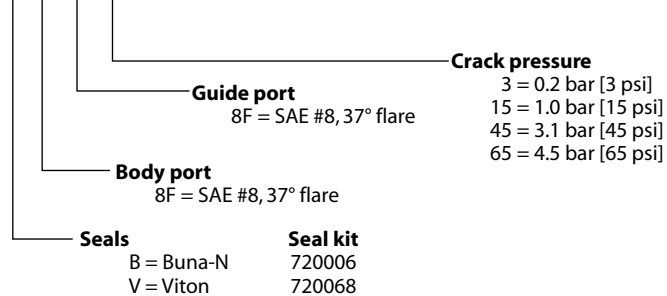

**OPERATION**

This valve allows free flow from 1 to 2 and blocks flow from 2 to 1.

**SPECIFICATIONS**

Theoretical performance

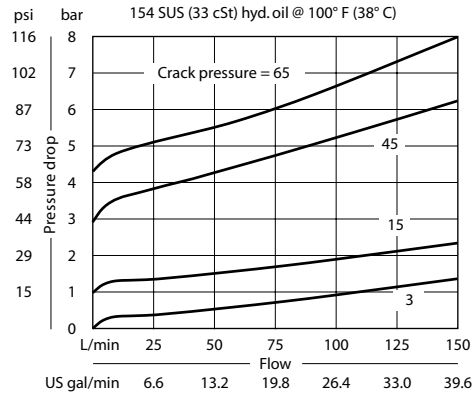

Schematic



Specifications

Rated pressure	350 bar [5075 psi]
Rated flow at 7 bar	150 l/min
100 psi	[40 US gal/min]
Leakage	5 drops/min @ Rated pressure
Weight	0.85 kg [1.87 lb]
Cavity	none

**DIMENSIONS**

mm in

Cross-sectional view

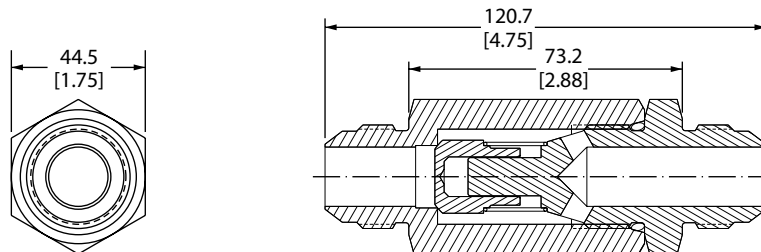

**ORDERING INFORMATION**

3CM15-01-B-16F-16F-03

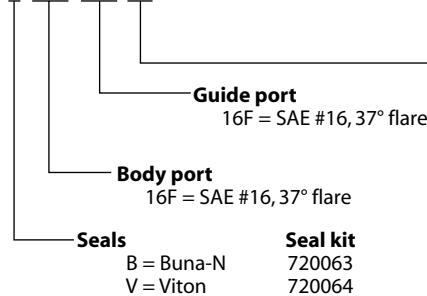

**OPERATION**

This valve allows free flow from 1 to 2 and restricted flow from 2 to 1.

**SPECIFICATIONS**

**Theoretical performance**

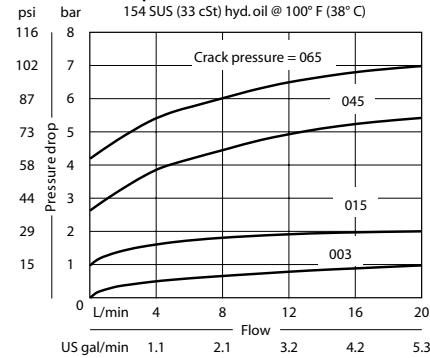

**Schematic**

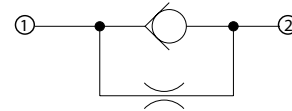

**Specifications**

Rated pressure	350 bar [5075 psi]
Rated flow at 7 bar	20 l/min
100 psi	[5 US gal/min]
Weight	0.11 kg [0.24 lb]
Cavity	none

**DIMENSIONS**

mm in

**Cross-sectional view**

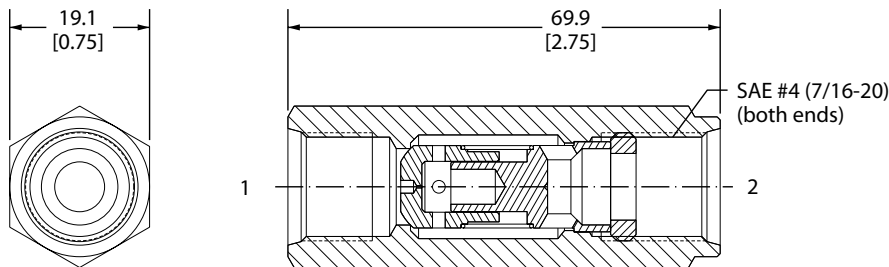

**ORDERING INFORMATION**

2RN11-01-4S-003-021

**Port sizes**  
 4S = SAE #4

**Orifice size**  
 021 = 0.53 mm [0.021 in]  
 030 = 0.76 mm [0.030 in]

**Crack pressure**  
 003 = 0.2 bar [3 psi]  
 015 = 1.0 bar [15 psi]  
 045 = 3.1 bar [45 psi]  
 065 = 4.5 bar [65 psi]