



BACKLASH FREE TORQUE LIMITERS

0.1 - 2,800 Nm



GENERAL INFORMATION ABOUT R+W SAFETY COUPLINGS:



SERVICE LIFE

As long as the technical limits are not exceeded these couplings are wear and maintenance free.

FIT CLEARANCE

Overall shaft / hub clearance of 0.01 - 0.05 mm

SPECIAL SOLUTIONS

Various materials, tolerances, dimensions and performance ratings available for custom applications on request.

ATEX (Optional)

For use in hazardous zones 1/21 and 2/22, these safety couplings have been authorized under directive 94/9/EG and are available with certification.

BACKLASH FREE TORQUE LIMITERS 0.1 - 2,800 Nm

MODEL		FEATURES	
SK1		<p>with conical clamping bushing (or clamping hub in smaller sizes) for indirect drives from 0.1 - 2,800 Nm</p> <ul style="list-style-type: none"> ▶ integral bearing to support sprockets, gears, and other drive elements ▶ compact simple design ▶ adjustable torque settings 	Pages 92-93
SKP		<p>with keyway connection for indirect drives from 0.1 - 2,800 Nm</p> <ul style="list-style-type: none"> ▶ integral bearing to support sprockets, gears, and other drive elements ▶ compact simple design ▶ adjustable torque settings 	Pages 94-95
SKN		<p>with clamping hub for indirect drives from 5 - 1,800 Nm</p> <ul style="list-style-type: none"> ▶ integral bearing to support sprockets, gears, and other drive elements ▶ compact simple design ▶ adjustable torque settings 	Pages 96-97
SK2		<p>with clamping hubs and bellows coupling for direct drives from 0.1 - 1,800 Nm</p> <ul style="list-style-type: none"> ▶ easy to mount ▶ compensation for shaft misalignment ▶ adjustable torque settings 	Page 98

MODEL

FEATURES

SK3



with conical clamping bushings and bellows coupling for direct drives from 5 - 2,800 Nm

- ▶ high clamping pressure
- ▶ compensation for shaft misalignment
- ▶ adjustable torque settings

Page 99

SK5



with clamping hubs, bellows coupling, and blind mate system for direct drives from 0.1 - 850 Nm

- ▶ very easy to mount and dismount
- ▶ electrically and thermally isolating
- ▶ adjustable torque settings

Page 100

ES2



with clamping hubs and elastomer coupling for direct drives from 1 - 1,800 Nm





- ▶ easy to mount
- ▶ vibration damping
- ▶ compensation for shaft misalignment
- ▶ adjustable torque settings

Page 101



BACKLASH FREE TORQUE LIMITERS TORQLIGHT®

0.1 - 2,800 Nm

MODEL		FEATURES	
SLN		with clamping hub for indirect drives from 10 - 700 Nm <ul style="list-style-type: none"> ▶ integral bearing to support sprockets, gears, and other drive elements ▶ adjustable torque settings ▶ ultra compact, low inertia version 	Page 103
SLP		with keyway connection for indirect drives from 10 - 700 Nm <ul style="list-style-type: none"> ▶ integral bearing to support sprockets, gears, and other drive elements ▶ adjustable torque settings ▶ ultra compact, low inertia version 	Page 104
SL2		with clamping hubs and bellows coupling for direct drives from 10 - 400 Nm <ul style="list-style-type: none"> ▶ easy to mount ▶ compensation for shaft misalignment ▶ adjustable torque settings ▶ ultra compact, low inertia version 	Page 105
SLE		with clamping hubs and elastomer coupling for direct drives from 10 - 700 Nm <ul style="list-style-type: none"> ▶ easy to mount ▶ vibration damping ▶ compensation for shaft misalignment ▶ adjustable torque settings ▶ ultra compact, low inertia version 	Page 106
ESL		with keyway mounting and elastomer coupling for direct drives from 1 - 150 Nm <ul style="list-style-type: none"> ▶ low cost design ▶ vibration damping ▶ wear resistant ratcheting ball design 	Page 107
ACCESSORIES		Accessories for safety couplings	Page 109-113

GENERAL INFORMATION

TORQUE LIMITERS

AVAILABLE FUNCTION SYSTEMS

TORQUE LIMITERS



SINGLE POSITION

Standard Version

- ▶ after the overload condition has been removed the clutch will automatically re-engage precisely at its original orientation
- ▶ maintains synchronous shaft positioning
- ▶ switch plate moves at disengagement to signal overload
- ▶ patented preload for zero backlash; suitable for high precision drives



MULTI-POSITION 60°

- ▶ after the overload condition has been removed the clutch will automatically re-engage at one of multiple angular intervals
- ▶ immediate availability of the machine after overload disengagement
- ▶ switch plate moves at disengagement to signal overload
- ▶ optional re-engagement intervals of 30, 45, 90, 120 degrees
- ▶ patented preload for zero backlash; suitable for high precision drives



FULL DISENGAGEMENT

- ▶ spring snaps over center, eliminating residual force on the ball-detent system
- ▶ complete separation at overload, allowing shafts to spin freely until they are stopped
- ▶ switch plate moves at disengagement to signal overload
- ▶ coupling requires manual re-engagement at multiple available intervals (60 degrees standard; alternate engagement intervals on request)
- ▶ well suited to higher speed applications

Note: Coupling can be disengaged manually. Contact R+W for details.

spring shown in disengaged state

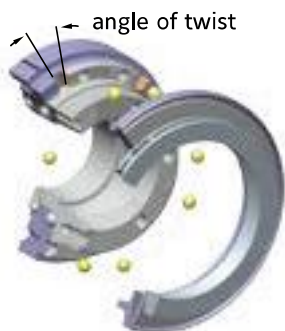

LOAD HOLDING / LOAD BLOCKING

- ▶ overload detection device
- ▶ only limited free rotation after overload disengagement, beyond which the clutch is fully blocked
- ▶ re-engages automatically when reversed back into original disengagement position
- ▶ switch plate moves at disengagement to signal overload
- ▶ useful in lift systems and other applications where the load must be supported after a brief torque release

GENERAL INFORMATION

TORQUE LIMITERS

SINGLE POSITION
MULTI-POSITION
LOAD HOLDING

Note: Automatic re-engagement only occurs at low speed.

GENERAL INFORMATION

R+W safety couplings operate as spring loaded ball-detent clutches. They protect drive components (e.g. motors, transmissions, and spindles) from damage caused by machine crashes and other forms of overload.

- ▶ The torque is transmitted by hardened balls (4) loaded into conical detents (5).
- ▶ The balls are loaded into the detents by the spring disc system (2) across the switch plate (3).
- ▶ The disengagement torque is continuously adjustable via the torque adjustment nut (1).
- ▶ At overload the balls exit their detents, moving the switch plate (3) and disc spring system (2) back away from the detents, separating the input from the output of the safety coupling.
- ▶ The movement of the switch plate (3) can be detected by a proximity switch (6) to signal the drive to shut down.

FUNCTION OF THE BALL-DETENT SYSTEM

SK SL ES2

SINGLE POSITION / MULTI-POSITION

In these designs the disc spring system continues to apply a light residual pressure when in its disengaged state. This pressure is sufficient to cause automatic re-engagement after the torque has been reduced to a level below the torque setting of the safety coupling.

SK ES2

LOAD HOLDING / LOAD BLOCKING

The input and output of the safety coupling are only allowed limited free rotation after disengagement. This free rotation is sufficient to allow the switch plate to move and the overload condition to be signaled (see page 85).

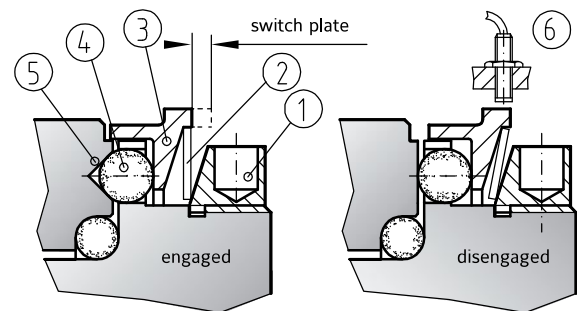

- ① Torque adjustment nut
- ② Disc spring system
- ③ Switch plate
- ④ Drive ball
- ⑤ Conical detent
- ⑥ Proximity switch

GENERAL INFORMATION

TORQUE LIMITERS

FULL DISENGAGEMENT

Only attempt re-engagement when the machine is stopped.

FUNCTION OF THE BALL-DETENT SYSTEM

SK

ES2

FULL DISENGAGEMENT

In the full disengagement version the spring system (7) snaps over center, eliminating residual force on the ball-detent system. This causes a complete separation at overload, allowing shafts to spin freely until they are stopped.

- Re-engagement must be performed manually (see figure at right).

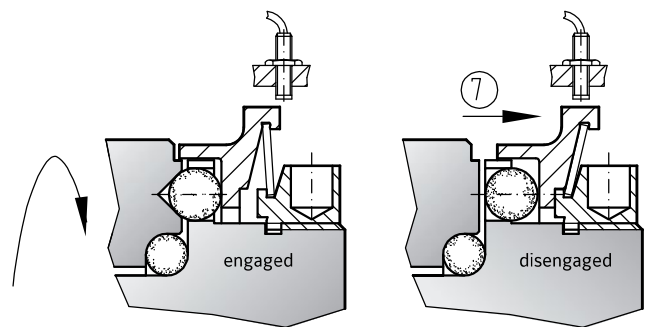

BALL-DETENT CLUTCHES ARE THE SAME DESIGN IN THE SK AND ES2 SIZES

The R+W full disengagement safety coupling can be re-engaged at any of 6 intervals by pressing the spring system back into its locked position. The re-engagement intervals are indicated by reference markings (8) on the coupling.

From size 60 and up a recess is included in the torque adjustment nut, allowing for 2 levers to be used in a self contained fashion, as shown in the figure on the right.

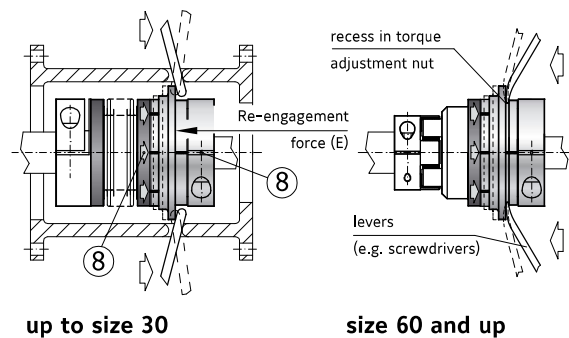

SAFETY COUPLINGS
SK | ES | SL

GENERAL INFORMATION TORQUE LIMITERS

BEHAVIOR AND CHARACTERISTICS

SPRING SYSTEM

R+W safety couplings work exclusively with a disc spring system with a special characteristic. Prior to the torque adjustment nut coming into contact with the disc springs and applying pressure (1) no torque transmission is possible. Once the spring is loaded, the active range of the spring system had been reached, with the spring rate declining as further compression takes place, both prior to, and during disengagement (2). Once completely depressed, the spring system is rigid (3).

As the safety coupling is in the process of disengaging, the spring force continues to decline. This advantage guarantees the shortest possible disengagement times (1-2 msec), very low wear while running disengaged, and very low residual friction in general (2-5%).

IMPORTANT!

The minimum and maximum torque values of the R+W safety couplings are at the limits of the active range of the disc spring system. Therefore it is critical not to exit the manufacturer specified torque adjustment range.

ROTATIONAL SPEED

The rotational speed at disengagement significantly influences the service life of the coupling. At lower speeds the coupling can handle many thousands of disengagements with no degradation to performance. Please contact R+W for details if applying the safety coupling to a high speed shaft.

WEAR

In its engaged state the safety coupling is completely wear free. Service life can be extended significantly by taking measures to stop shaft rotation quickly after disengagement.

MAINTENANCE

The R+W safety couplings are maintenance free and lubricated for life.

SPRING CHARACTERISTIC

special design

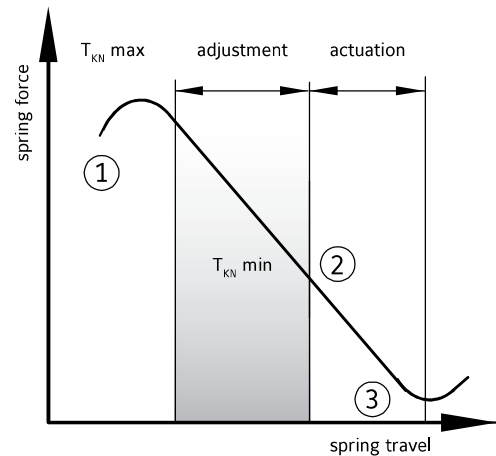

DISENGAGEMENT

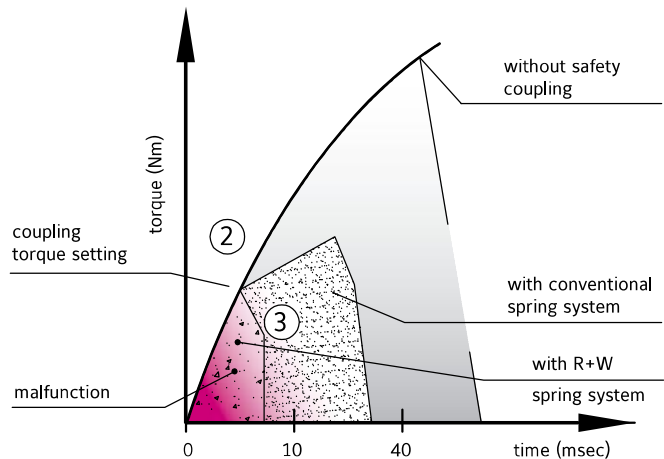

SAFETY COUPLING WITH SEAL (OPTIONAL)

Benefits of sealing:

- ▶ Protection from harmful contaminants
- ▶ No leakage of grease
- ▶ Recommended for harsh environments or clean room / sanitary application requirements

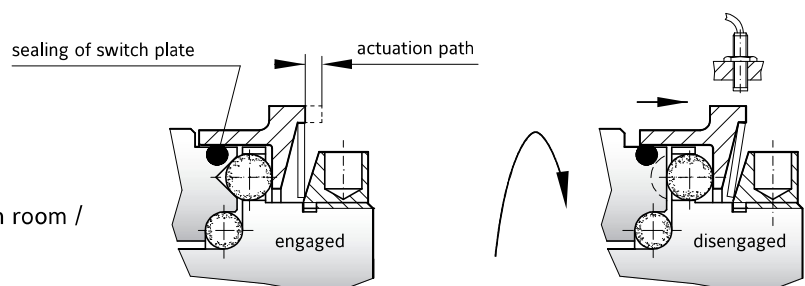

GENERAL INFORMATION

TORQUE LIMITERS

RADIAL LOADS

SAFETY COUPLINGS

SK1

SKN

SKP

SLN

SLP

The models shown above have an integral bearing (1) to support the drive attachment (e.g. timing belt or chain sprocket, gear, or hand wheel). The maximum radial load (2) is listed in the table below.

If the center of the overhung load is located within dimension range (S) no additional bearing support is necessary. For offset mounting additional bearings can be used to support the load. This is useful in cases where the attached component is too small to fit over the coupling output flange or has a large width.

Depending on the installation space, ball, roller or needle bearings can all be used.

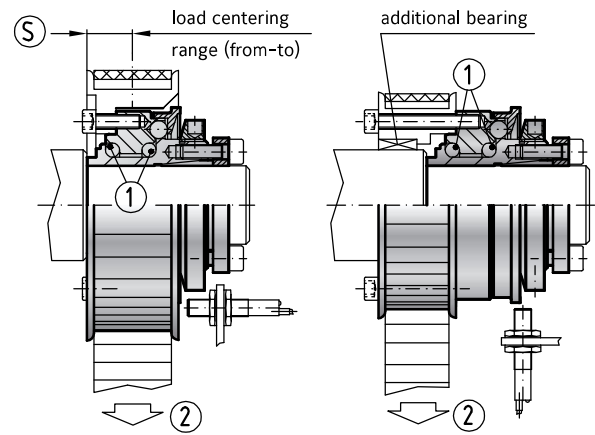

SIZE SK1/SKN/SKP	1.5	2	4.5	10	15	30	60	150	200	300	500	800	1500	2500
Max. radial load (N)	50	100	200	500	1400	1800	2300	3000	3500	4500	5600	8000	12000	20000
(S) from-to (mm)	3-6	5-8	5-11	6-14	7-17	10-24	10-24	12-24	12-26	12-28	16-38	16-42	20-50	28-60

SIZE SLN/SLP	30	60	150	300
Max. radial load (N)	800	1000	1200	1600
(S) from-to (mm)	4-14	5-18	6-20	6-23

SK1

WITH CONICAL CLAM

0.1 - 2,800 Nm



PROPERTIES

MATERIAL

- ▶ **Clutch system:** hardened steel
- ▶ **Clamping ring size 1.5 - 10:** aluminum
- ▶ **Conical clamping bushing size 15 - 2500:** steel

DESIGN

Size 1.5 - 10 with clamping ring and a single clamping screw.

Size 15 - 2500 with conical clamping bushing and six screws.

Clutch system: spring loaded ball-detent principle. Operable temperature range from -30 to +120° C.

AVAILABLE FUNCTION SYSTEMS

- ▶ **W = Single position / automatic re-engagement (standard)**
- ▶ **D = Multi-position / automatic re-engagement**
- ▶ **G = Load holding / load blocking**
- ▶ **F = Full disengagement / manual re-engagement**



MINIATURE DESIGN | SIZE 1.5 - 10

Standard with clamping collar

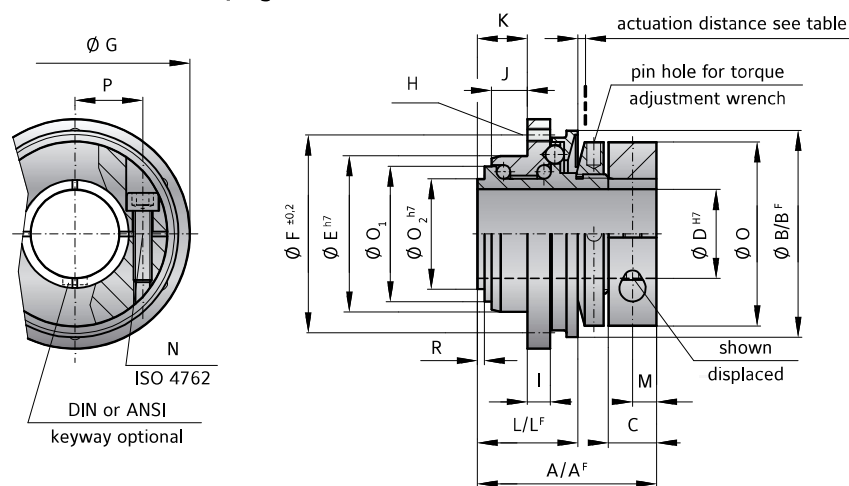

STANDARD DESIGN | SIZE 15 - 2,500

Standard with conical clamping bushing

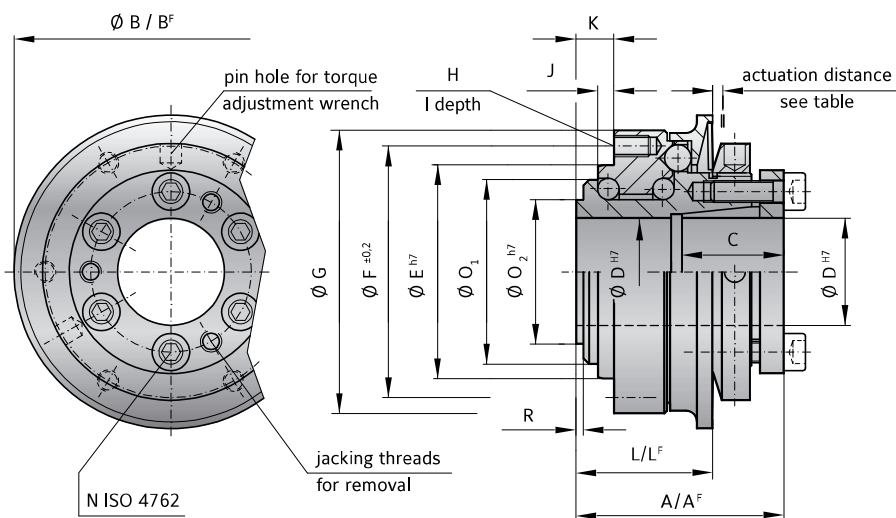

MODEL SK1

SIZE		MINIATURE DESIGN													
		1.5	2	4.5	10	15	30	60	150	200	300	500	800	1500	2500
Adjustment range available from - to (approx. values) (Nm)	T _{KN}	0.1-0.6 0.4-1 0.8-2	0.2-1.5 0.5-2.2 1.5-3.5	1-3 2-4.5 3-7	2-6 4-12 7-18	5-15 12-25 20-40 35-70	5-20 10-30 20-60 50-100	10-30 25-80 50-115	20-70 45-150 80-225	30-90 60-160 140-280 250-400	100-200 150-240 220-440	80-200 200-350 320-650	400-650 500-800 650-950	600-800 700-1200 1000-1800	1500-2000 2000-2500 2300-2800
Adjustment range available from - to (approx. values) ("F" Version) (Nm)	T _{KN}	0.3-0.8 or 0.6-1.3	0.2-1 or 0.7-2	2.5-4.5	2-5 4-10 8-15	7-15	8-20 or 16-30	10-30 20-40 30-60	20-60 40-80 80-150	80-140 or 130-200	120-180 160-300 300-450	50-150 100-300 250-500	200-400 or 450-850	1000-1250 or 1250-1500	1400-2200 or 1800-2700
Overall length (mm)	A	23	28	32	39	40	50	54	58	63	70	84	95	109	146
Overall length ("F" Version) (mm)	A ^F	23	28	32	39	40	50	54	58	66	73	88	95	117	152
Actuation ring Ø (mm)	B	23	29	35	45	55	65	73	92	99	120	135	152	174	242
Actuation ring Ø, ("F" Version) (mm)	B ^F	24	32	42	51.5	62	70	83	98	117	132	155	177	187	258
Clamping fit length (mm)	C	7	8	11	11	19	22	27.5	32	32	41	41	49	61	80
Inner diameter from Ø to Ø H7 (mm)	D	4-8	4-12	5-14	6-16	8-22	12-22	12-29	15-37	20-44	25-56	25-56	30-60	35-70	50-100
Pilot diameter h7 (mm)	E	14	22	25	34	40	47	55	68	75	82	90	100	125	168
Bolt-hole circle diameter ± 0.2 (mm)	F	22	28	35	43	47	54	63	78	85	98	110	120	148	202
Flange outside diameter -0.2 (mm)	G	26	32	40	50	53	63	72	87	98	112	128	140	165	240
Thread	H	4xM2	4xM2.5	6xM2.5	6xM3	6xM4	6xM5	6xM5	6xM6	6xM6	6xM8	6xM8	6xM10	6xM12	6xM16
Thread depth (mm)	I	3	4	4	5	6	8	9	10	10	10	12	15	16	24
Centering length -0.2 (mm)	J	2.5	3.5	5	8	3	5	5	5	5	6	9	10	13.5	20
Distance (mm)	K	5	6	8	11	8	11	11	12	12	15	21	19	25	34
Distance (mm)	L	11	15	17	22	27	35	37	39	44	47	59	67	82	112
Distance, ("F" Version) (mm)	L ^F	11.5	16	18	24	27	37	39	41.5	47	51.5	68	75	94	120
Distance	M	3.5	4	5	5										
Screw ISO 4762	N	1xM2.5	1xM3	1xM4	1xM4	6xM4	6xM5	6xM5	6xM6	6xM6	6xM8	6xM8	6xM10	6xM12	6xM16
Tightening torque (Nm)		1	2	4	4.5	4	6	8	12	14	18	25	40	70	120
Outside diameter clamp ring Ø (mm)	O	20	25	32	40										
Diameter (mm)	O ₁	13	18	21	30	35	42	49	62	67	75	84	91	112	154
Diameter h7 (mm)	O ₂	11	14	17	24	27	32	39	50	55	65	72	75	92	128
Distance between centers (mm)	P	6.5	8	10	15										
Distance (mm)	R	1	1.3	1.5	1.5	2.5	2.5	2.5	2.5	3	3	4	4	4.5	6
Moment of inertia (10 ⁻³ kgm ²)	J _{ges}	0.01	0.02	0.05	0.07	0.15	0.25	0.50	1.60	2.70	5.20	8.6	20	31.5	210
Approx. weight (kg)		0.03	0.065	0.12	0.22	0.4	0.7	1.0	1.3	2.0	3.0	4.0	5.5	10	28
Actuation distance (mm)		0.7	0.8	0.8	1.2	1.5	1.7	1.7	1.9	2.2	2.2	2.2	2.2	3.0	3.0

A^F, B^F, L^F = Full disengagement / manual re-engagement version (F)

ORDERING EXAMPLE	SK1	10	W	12.7	4	2-6	XX
Model	●						Special designation only (e.g. special bore / keyway dimensions).
Size		●					
Function system			●				
Bore D1 H7				●			
Disengagement torque Nm					●		
Torque adjustment range Nm						●	
For custom features place an XX at the end of the part number and describe the special requirements (e.g. SK1 / 10 / W / 12.7 / 4 / 2-6 / XX; XX=stainless steel)							

PROPERTIES

MATERIAL

► **Clutch system:** hardened steel

DESIGN

With DIN 6885 or ANSI B17.1 keyway.
Clutch system: spring loaded ball-detent principle. Operable temperature range from -30 to +120° C.

AVAILABLE FUNCTION SYSTEMS

- W = Single position / automatic re-engagement (standard)
- D = Multi-position / automatic re-engagement
- G = Load holding / load blocking
- F = Full disengagement / manual re-engagement



MINIATURE DESIGN | SIZE 1.5 - 10

Standard with keyway mounting

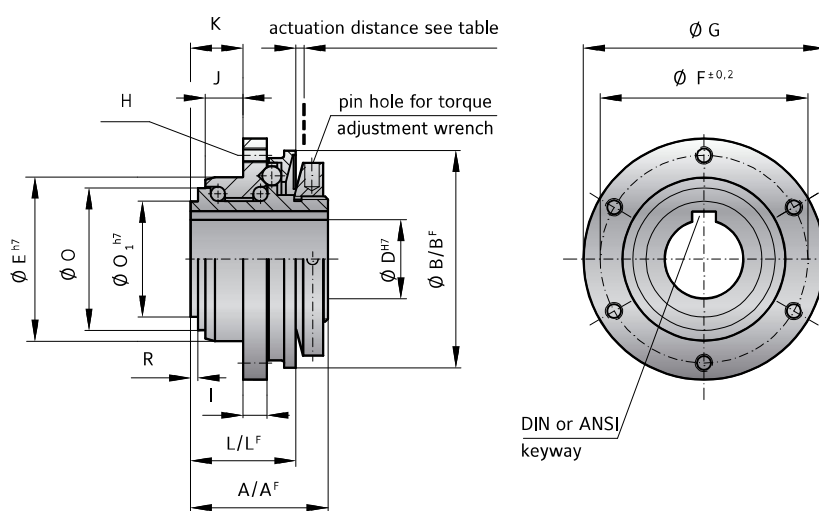

STANDARD DESIGN | SIZE 15 - 2,500

Standard with keyway mounting

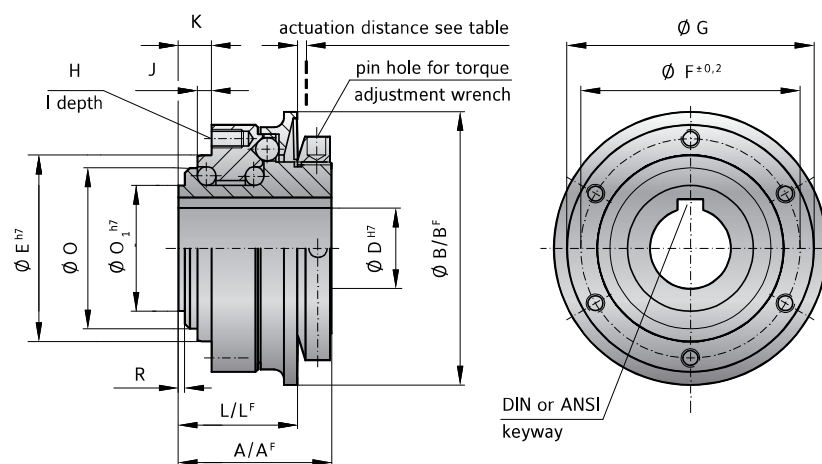

MODEL SKP

SIZE		MINIATURE DESIGN													
		1.5	2	4.5	10	15	30	60	150	200	300	500	800	1500	2500
Adjustment range available from - to (approx. values)	(Nm) T_{KN}	0.1-0.6 0.4-1 0.8-2	0.2-1.5 0.5-2.2 1.5-3.5	1-3 2-4.5 3-7	2-6 4-12 7-18	5-15 12-25 20-40 35-70	5-20 10-30 20-60 50-100	10-30 25-80 50-115	20-70 45-150 80-225	30-90 60-160 140-280 250-400	100-200 150-240 220-440	80-200 200-350 320-650	400-650 500-800 650-950	600-800 700-1200 1000-1800	1500-2000 2000-2500 2300-2800
Adjustment range available from - to (approx. values) ("F" Version)	(Nm) T_{KN}	0.3-0.8 or 0.6-1.3	0.2-1 or 0.7-2	2.5-4.5	2-5 4-10 8-15	7-15	8-20 or 16-30	10-30 20-40 30-60	20-60 40-80 80-150	80-140 or 130-200	120-180 160-300 300-450	50-150 100-300 250-400	200-400 or 450-850	1000-1250 or 1250-1500	1400-2200 or 1800-2700
Overall length A	(mm) A	15.5	20	22	28	34	43	46	48.5	54	57	71.5	80	99	135
Overall length ("F" Version)	(mm) A ^F	15.5	20	22	28	34	43	46	48.5	57	60	75	91	110	141
Actuation ring Ø	(mm) B	23	29	35	45	55	65	73	92	99	120	135	152	174	242
Actuation ring Ø, ("F" Version)	(mm) B ^F	24	32	42	51.5	62	70	83	98	117	132	155	177	187	258
Inner diameter from Ø to Ø H7	(mm) D	4-8*	4-10*	4-12*	4-16*	8-18	12-24.5	12-28	15-38	20-42	25-50	25-58	30-60	35-73	50-95
Pilot diameter h7	(mm) E	14	22	25	34	40	47	55	68	75	82	90	100	125	168
Bolt-hole circle diameter ± 0.2	(mm) F	22	28	35	43	47	54	63	78	85	98	110	120	148	202
Flange outside diameter -0.2	(mm) G	26	32	40	50	53	63	72	87	98	112	128	140	165	240
Thread	H	4xM2	4xM2.5	6xM2.5	6xM3	6xM4	6xM5	6xM5	6xM6	6xM6	6xM8	6xM8	6xM10	6xM12	6xM16
Thread depth	(mm) I	3	4	4	5	6	8	9	10	10	10	12	15	16	24
Centering length -0.2	(mm) J	2.5	3.5	5	8	3	5	5	5	5	6	9	10	13.5	20
Distance	(mm) K	5	6	8	11	8	11	11	12	12	15	21	19	25	34
Distance	(mm) L	11	15	17	22	27	35	37	39	44	47	59	67	82	112
Distance, ("F" Version)	(mm) L ^F	11.5	16	18	24	27	37	39	41.5	47	51.5	68	75	94	120
Diameter	(mm) O	13	18	21	30	35	42	49	62	67	75	84	91	112	154
Diameter h7	(mm) O ₁	11	14	17	24	27	32	39	50	55	65	72	75	92	128
Distance	(mm) R	1	1.3	1.5	1.5	2.5	2.5	2.5	2.5	3	3	4	4	4.5	6
Moment of inertia (10 ⁻³ kgm ²)	J _{ges}	0.01	0.02	0.05	0.07	0.15	0.25	0.50	1.60	2.70	5.20	8.6	20	31.5	210
Approx. weight	(kg)	0.03	0.065	0.12	0.22	0.4	0.7	1.0	1.3	2.0	3.0	4.0	5.5	10	28
Actuation distance	(mm)	0.7	0.8	0.8	1.2	1.5	1.5	1.7	1.9	2.2	2.2	2.2	2.2	3.0	3.0

A^F, B^F, L^F = Full disengagement / manual re-engagement version (F) *Ø 12 mm only available with shallow keyway (height = 1.2mm^{+0.2})
 * bore diameter < 6 mm delivered without keyway

KEYWAY ACCORDING TO DIN 6885 (R+W STANDARD)

D ₁ from to	6	8	10	12	17	22	30	38	44	50	58	65	75	85	95	110
b ⁵⁹	2	3	4	5	6	8	10	12	14	16	18	20	22	25	28	
h	2	3	4	5	6	7	8	8	9	10	11	12	14	14	16	
t ₁	1.2	1.8	2.5	3	3.5	4	5	5	5.5	6	7	7.5	9	9	10	
t ₂ ^{+0.1/+0.2}	1	1.4	1.8	2.3	2.8	3.3	3.3	3.3	3.8	4.3	4.4	4.9	5.4	5.4	6.4	

Bore diameters specified as common inch sizes receive standard keyways according to ANSI B17.1. Special keyway dimensions are also available upon request.

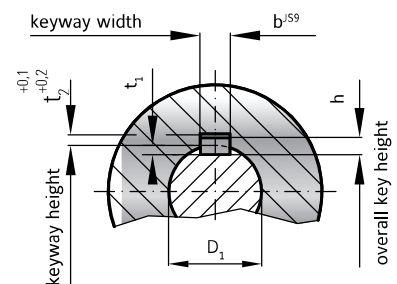

ORDERING EXAMPLE	SKP	10	W	15.88	4	2-6	XX
Model	●						Special designation only (e.g. special bore / keyway dimensions).
Size		●					
Function system			●				
Bore D1 H7				●			
Disengagement torque Nm					●		
Torque adjustment range Nm						●	
For custom features place an XX at the end of the part number and describe the special requirements (e.g. SKP / 10 / W / 15.88 / 4 / 2-6 / XX; XX=stainless steel)							

PROPERTIES

MATERIAL

- ▶ **Clutch system:** hardened steel
- ▶ **Clamping collar:** up to size 500 aluminum, size 800 and up steel

DESIGN

With clamping ring and one clamping screw. Clutch system: spring loaded ball-detent principle. Operable temperature range from -30 to +120° C.

AVAILABLE FUNCTION SYSTEMS

- ▶ W = Single position / automatic re-engagement (standard)
- ▶ D = Multi-position / automatic re-engagement
- ▶ G = Load holding / load blocking
- ▶ F = Full disengagement / manual re-engagement



STANDARD DESIGN | SIZE 15 - 1,500

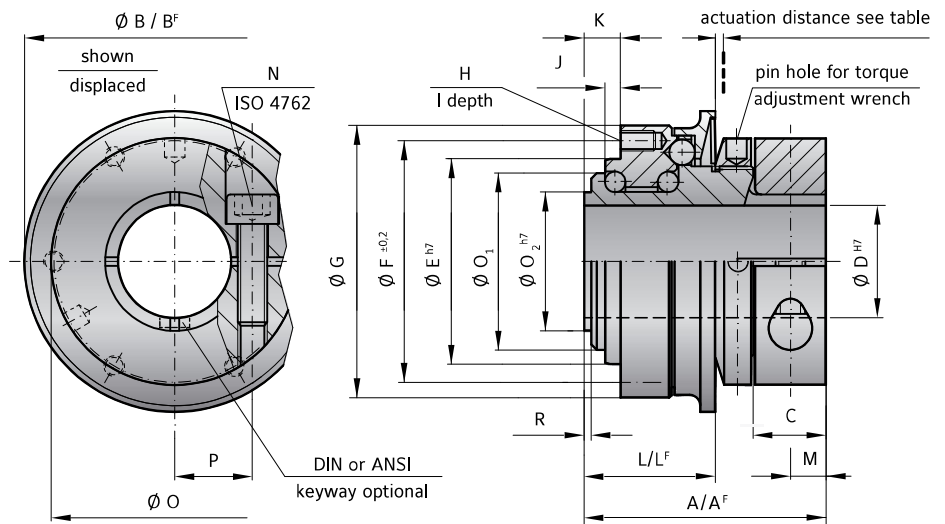

MODEL SKN

SIZE		15	30	60	150	200	300	500	800	1500
Adjustment range available from - to (approx. values)	(Nm) T _{KN}	5-10 or 8-20	10-25 or 20-40	10-30 or 25-80	20-70 45-150 80-180	30-90 60-160 120-240	100-200 150-240 200-320	80-200 200-350 300-500	400-650 500-800 600-850	600-800 700-1200 1000-1800
Adjustment range available from - to (approx. values) ("F" Version)	(Nm) T _{KN}	7-15	8-20 or 16-30	10-30 20-40 30-60	20-60 40-80 80-150	80-140 or 130-200	120-180 or 160-300	50-150 100-300 250-500	200-400 or 450-800	1000-1250 or 1250-1500
Overall length	(mm) A	47	59	65	71	80	84	101	115	145
Overall length, ("F" Version)	(mm) A ^F	47	59	65	73	83	87	107	126	160
Actuation ring Ø	(mm) B	55	65	73	92	99	120	135	152	174
Actuation ring Ø, ("F" Version)	(mm) B ^F	62	70	83	98	117	132	155	177	187
Clamping fit length	(mm) C	13.5	16	20	23	26	26	30	35	46
Inside diameter from Ø to Ø H7	(mm) D	12-22*	14-25.4*	16-32	19-40*	24-44	30-56*	35-60*	40-62*	50-72*
Pilot diameter h7	(mm) E	40	47	55	68	75	82	90	100	125
Bolt-hole circle diameter ± 0.2	(mm) F	47	54	63	78	85	98	110	120	148
Flange outside diameter -0.2	(mm) G	53	63	72	87	98	112	128	140	165
Thread	H	6xM4	6xM5	6xM5	6xM6	6xM6	6xM8	6xM8	6xM10	6xM12
Thread depth	(mm) I	6	8	9	10	10	10	12	15	16
Centering length -0.2	(mm) J	3	5	5	5	5	6	9	10	13.5
Distance	(mm) K	8	11	11	12	12	15	21	19	25
Distance	(mm) L	27	35	37	39	44	47	59	67	82
Distance, ("F" Version)	(mm) L ^F	27	37	39	41.5	47	51.5	68	75	94
Distance	M	6.5	7.5	9.5	11	13	13	14.5	18	22.5
Screw ISO 4762	N	M5	M6	M8	M10	M12	M12	M14	M16	M20
Tightening torque		8	15	40	70	120	130	210	270	500
Clamp ring Ø	O	49	55	67	85	94	110	121	134	157
Diameter	(mm) O ₁	35	42	49	62	67	75	84	91	112
Diameter h7	(mm) O ₂	27	36	39	50	55	65	72	75	92
Distance between centers	(mm) P	17.5	19	23.5	30	32.5	39	43.5	45	52
Distance	(mm) R	2.5	2.5	2.5	2.5	3	3	4	4	4.5
Moment of inertia (10 ⁻³ kgm ²)	J _{ges}	0.15	0.25	0.50	1.60	2.70	5.20	8.60	20	31.5
Approx. weight	(kg)	0.4	0.7	1.0	1.3	2.0	3.0	4.0	5.5	10
Actuation distance	(mm)	1.5	1.5	1.7	1.9	2.2	2.2	2.2	2.2	3.0

A^F, B^F, L^F = Full disengagement / manual re-engagement version (F)

* keyway with max. bore only in clamping hub possible.

ORDERING EXAMPLE	SKN	60	W	19.05	60	25-80	XX
Model	●						Special designation only (e.g. special bore / keyway dimensions).
Size		●					
Function system			●				
Bore D1 H7				●			
Disengagement torque Nm					●		
Torque adjustment range Nm						●	
For custom features place an XX at the end of the part number and describe the special requirements (e.g. SKN / 60 / W / 19.05 / 60 / 25-80 / XX; XX=stainless steel)							

SK2

WITH CLAMPING HUBS

0.1 - 1,800 Nm



PROPERTIES

MATERIAL

- ▶ **Bellows:** high grade stainless steel
- ▶ **Clutch system:** hardened steel
- ▶ **Clamping hubs:** up to size 80 aluminum, size 150 and up steel

temperature range from -30 to +100° C.

AVAILABLE FUNCTION SYSTEMS

- ▶ **W = Single position / automatic re-engagement (standard)**
- ▶ **D = Multi-position / automatic re-engagement**
- ▶ **G = Load holding / load blocking**
- ▶ **F = Full disengagement / manual re-engagement**

DESIGN

Two clamping hubs with one clamping screw in each. Clutch system: spring loaded ball-detent principle. Operable

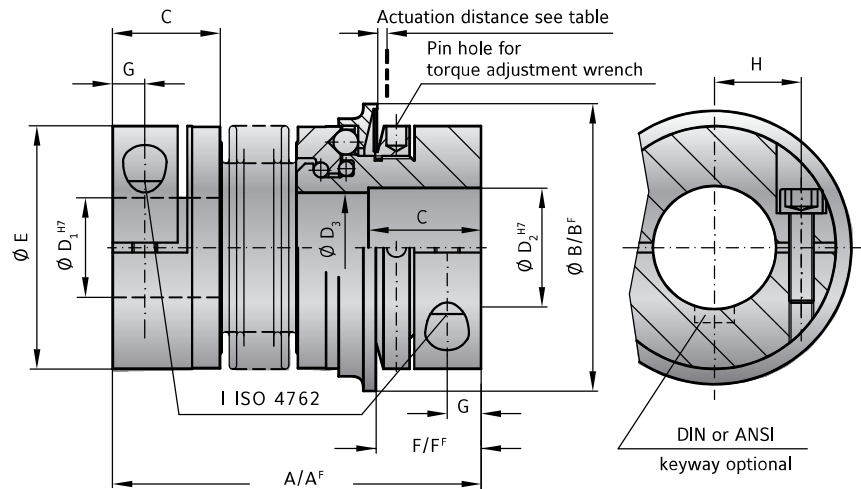

MODEL SK2

SIZE		1.5	2	4.5	10	15	30	60	80	150	200	300	500	800	1500
Adjustment range available from - to (approx. values) (Nm)	T _{KN}	0.1-0.6 0.4-1 0.8-1.5	0.2-1.5 or 0.5-2	1-3 or 3-6	2-6 or 4-12	5-10 or 8-20	10-25 or 20-40	10-30 or 25-80	20-70 or 30-90	20-70 45-150 80-180	30-90 60-160 120-240	100-200 200-350 300-500	80-200 500-800 650-850	400-650 500-800 650-850	650-800 700-1200 1000-1800
Adjustment range available from - to (approx. values) ("F" Version) (Nm)	T _{KN}	0.3-0.8 or 0.6-1.3	0.2-1 or 0.7-2	2.5-4.5	2-5 or 5-10	7-15	8-20 or 16-30	20-40 or 30-60	20-60 or 40-80	20-60 40-80 80-150	80-140 or 130-200	120-180 or 160-300	60-150 100-300 250-500	200-400 or 450-800	1000-1250 or 1250-1500
Overall length (mm)	A	42	46 51	57 65	65 74	75 82	87 95	102 112	115 127	116 128	128 140	139 153	163 177	190	223
Overall length, ("F" Version) (mm)	A ^F	42	46 51	57 65	65 74	75 82	87 95	102 112	117 129	118 130	131 143	142 156	167 181	201	232
Actuation ring Ø (mm)	B	23	29	35	45	55	65	73	92	92	99	120	135	152	174
Actuation ring Ø, ("F" Version) (mm)	B ^F	24	32	42	51.5	62	70	83	98	98	117	132	155	177	187
Clamping fit length (mm)	C	11	13	16	16	22	27	31	35	35	40	42	51	48	67
Inside diameter from Ø to Ø H7 (mm)	D ₁ /D ₂	3-8*	4-12*	5-14*	6-16*	10-26	12-30	15-32	19-42	19-42	24-45	30-60	35-60	40-75	50-80
Diameter (mm)	D ₃	9.1	12.1	14.1	20.1	21.1	24.1	32.1	36.1	36.1	42.1	58.1	60.1	60.1	68.1
Outside diameter of coupling (mm)	E	19	25	32	40	49	55	66	81	81	90	110	123	134	157
Distance (mm)	F	12	13	15	17	19	24	28	31	31	35	35	45	50	63
Distance, ("F" Version) (mm)	F ^F	11.5	12	14	16	19	22	29	31	30	33	35	43	54	61
Distance (mm)	G	3.5	4	5	5	6.5	7.5	9.5	11	11	12.5	13	17	18	22.5
Distance between centers (mm)	H	6	8	10	15	17	19	23	27	27	31	39	41	2x48	2x55
Screw ISO 4762	I	M2.5	M3	M4	M4	M5	M6	M8	M10	M10	M12	M12	M16	2xM16	2xM20
Tightening torque (Nm)	I	1	2	4	4.5	8	15	40	50	70	120	130	200	250	470
Approx. weight (kg)		0.047	0.07	0.2	0.3	0.4	0.6	1.0	2.0	2.4	4.0	5.9	9.6	14	21
Moment of inertia (10 ⁻³ kgm ²)	J _{gvs}	0.01	0.01 0.01	0.02 0.02	0.06 0.07	0.10 0.15	0.27 0.32	0.75 0.80	1.80 1.90	2.50 2.80	5.10 5.30	11.5 11.8	22.8 23.0	42.0	83.0
Torsional stiffness (10 ³ Nm/rad)	C _T	0.7	1.2 1.3	7 5	9 8	20 15	39 28	76 55	129 85	175 110	191 140	420 350	510 500	780	1304
Lateral ± (mm)	max. values	0.15	0.15 0.20	0.20 0.25	0.20 0.30	0.15 0.20	0.20 0.25	0.20 0.25	0.20 0.25	0.20 0.25	0.25 0.30	0.25 0.30	0.30 0.35	0.35	0.35
Angular ± (Degree)	max. values	1	1 1.5	1.5 2	1.5 2	1 1.5	1 1.5	1 1.5	1 1.5	1 1.5	1.5 2	1.5 2	2 2.5	2.5	2.5
Lateral spring stiffness (N/mm)		70	40 30	290 45	280 145	475 137	900 270	1200 420	920 255	1550 435	2040 610	3750 1050	2500 840	2000	3600
Actuation distance (mm)		0.7	0.8	0.8	1.2	1.5	1.5	1.7	1.9	1.9	2.2	2.2	2.2	2.2	3

A^F, B^F, L^F = Full disengagement / manual re-engagement version (F)
* keyway with max. bore only in clamping hub possible.

Larger versions available upon request.

SK3

WITH CONICAL CLAMPING SYSTEM

5 – 2,800 Nm

PROPERTIES



MATERIAL

- ▶ **Bellows:** high grade stainless steel
- ▶ **Clutch system:** hardened steel
- ▶ **Clamping hubs / bushings:** steel

Operable temperature range from -30 to +100° C.

AVAILABLE FUNCTION SYSTEMS

- ▶ **W** = Single position / automatic re-engagement (standard)
- ▶ **D** = Multi-position / automatic re-engagement
- ▶ **G** = Load holding / load blocking
- ▶ **F** = Full disengagement / manual re-engagement

DESIGN

Two conical clamping assemblies with six tightening screws each, plus jack screws for removal. Clutch system: spring loaded ball-detent principle.

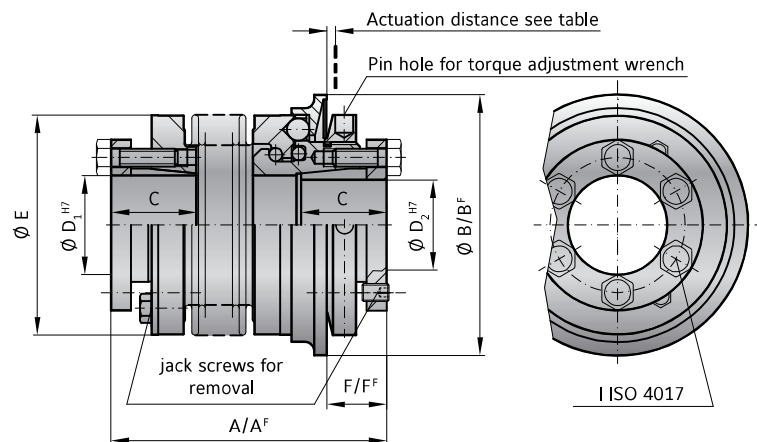

MODEL SK3

SIZE		15	30	60	150	200	300	500	800	1500	2500
Adjustment range available from (approx. values) (Nm)	T_{KN}	5-10 or 8-20	10-25 or 20-40	10-30 or 25-80	20-70 or 45-150 80-200	30-90 or 60-160 140-280	100-200 or 150-240 220-400	80-200 or 200-350 300-500	400-650 or 500-800 600-900	650-850 or 700-1200 1000-1800	1500-2000 or 2000-2500 2300-2800
Adjustment range available from (approx. values) ("F" Version) (Nm)	T_{KN}	7-15	8-20 or 16-30	20-40 or 30-60	20-60 or 40-80 80-150	80-140 or 130-200	120-180 or 160-300	60-150 or 100-300 250-500	200-400 or 450-800	1000-1250 or 1250-1500	1400-2200 or 1800-2700
Overall length ±2 (mm)	A	62 69	72 80	84 94	93 105	99 111	114 128	123 136	151	175	246
Overall length ("F" Version) ±2 (mm)	A ^F	62 69	72 80	84 94	93 105	102 114	117 131	127 140	151	184	252
Actuation ring Ø (mm)	B	55	65	73	92	99	120	135	152	174	243
Actuation ring Ø ("F" Version) (mm)	B ^F	62	70	83	98	117	132	155	177	187	258
Clamping fit length (mm)	C	19	22	27	32	32	41	41	49	61	80
Inside diameter from Ø to Ø H7 (mm)	D ₁ /D ₂	10-22	12-23	12-29	15-37	20-44	25-56	25-60	30-60	35-70	50-100
Outside diameter of coupling (mm)	E	49	55	66	81	90	110	123	133	157	200
Distance (mm)	F	13	16	18	19	19	23	25	31	30	34
Distance ("F" Version) (mm)	F ^F	13	14	17	18	17	20	22	20	26	31
6x Screw ISO 4017	I	M4	M5	M5	M6	M6	M8	M8	M10	M12	M16
Tightening torque (Nm)	I	4	6	8	12	14	18	25	40	70	120
Approx. weight (kg)		0.3	0.4	1.2	2.3	3.0	5.0	6.5	9.0	16.3	35
Moment of inertia (10 ⁻³ kgm ²)	J _{ges}	0.10 0.15	0.28 0.30	0.75 0.80	1.90 2.00	2.80 3.00	5.50 6.00	11.0 12.8	20	42	257
Torsional stiffness (10 ³ Nm/rad)	C _t	20 15	39 28	76 55	175 110	191 140	420 350	510 500	780	1304	3400
Lateral	max. values	0.15 0.20	0.20 0.25	0.20 0.25	0.20 0.25	0.25 0.30	0.25 0.30	0.30 0.35	0.35	0.35	0.35
Angular	max. values	1 1.5	1 1.5	1 1.5	1 1.5	1.5 2	1.5 2	2 2.5	2.5	2.5	2.5
Lateral spring stiffness		475 137	900 270	1200 380	1550 435	2040 610	3750 1050	2500 840	2000	3600	6070
Actuation distance		1.5	1.5	1.7	1.9	2.2	2.2	2.2	2.2	3	3

A^F. B^F. L^F = Full disengagement / manual re-engagement version (F) Larger versions available upon request.

ORDERING EXAMPLE	SK3 SK5	60	84	D	16	19.05	25	10-30	XX
Model	●								
Size		●							
Overall length mm			●						
Function system				●					
Bore D1 H7					●				
Bore D2 H7						●			
Disengagement torque Nm							●		
Torque adjustment range Nm								●	

For custom features place an XX at the end of the part number and describe the special requirements (e.g. SK3 / 60 / 84 / D / 16 / 19.05 / 25 / 10-30 / XX; XX=special 30 deg re-engagement angle)

SK5

BLIND MATE WITH CLAMPING HUBS

0.1 – 850 Nm



PROPERTIES

MATERIAL

- ▶ **Bellows:** high grade stainless steel
- ▶ **Clutch system:** hardened steel
- ▶ **Clamping hubs:** up to size 80 aluminum, size 150 and up steel
- ▶ **Tapered male segment:** high strength plastic

DESIGN

Two clamping hubs with one clamping screw each, and one of the clamping hubs with tapered male segment

for plug-in installation. Clutch system: spring loaded ball-detent principle. Operable temperature range from -30 to +100° C.

AVAILABLE FUNCTION SYSTEMS

- ▶ **W = Single position / automatic re-engagement (standard)**
- ▶ **D = Multi-position / automatic re-engagement**
- ▶ **G = Load holding / load blocking**
- ▶ **F = Full disengagement / manual re-engagement**

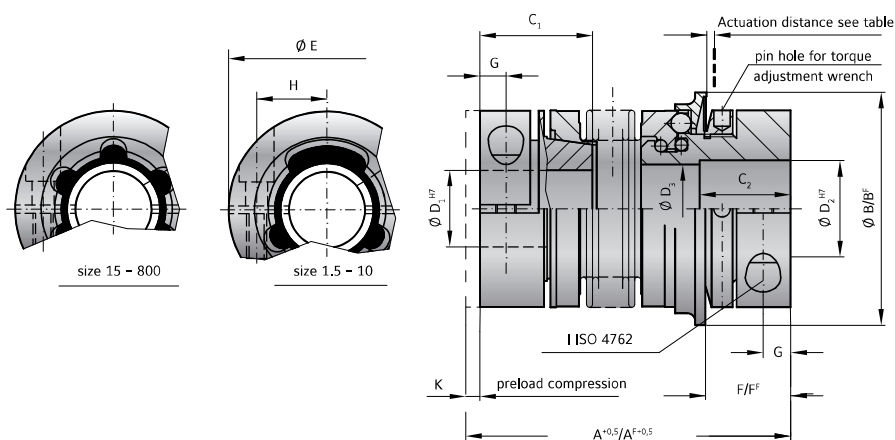

MODEL SK5

Size		1.5	2	4.5	10	15	30	60	80	150	300	500	800
Adjustment range available from - to (approx. values) (Nm)	T_{KN}	0.1-0.6 0.4-1 0.8-1.5	0.2-1.5 or 0.5-2	1-3 or 3-6	2-6 or 4-12	5-10 or 8-20	10-25 or 20-40	10-30 or 25-80	20-70 or 30-90	20-70 or 45-150	100-200 150-240 200-320	80-200 200-350 300-500	400-650 500-800 650-850
Adjustment range available from - to (approx. values) ("F" Version) (Nm)	T_{KN}	0.3-0.8 or 0.6-1.3	0.2-1 or 0.7-2	2.5-4.5	2-5 or 5-10	7-15	8-20 or 16-30	20-40 or 30-60	20-60 or 40-80	80-150	120-200 or 160-300	60-150 100-300 250-500	200-400 or 450-800
Overall length +0.5 (mm)	A	44	48 54	60 68	70 79	76 83	89 97	105 115	115 127	116 128	143 157	166 180	196
Overall length +0.5 ("F" Version) (mm)	A ^F	44	48 54	60 68	70 79	76 83	89 97	105 115	117 129	118 130	146 160	170 184	207
Actuation ring Ø (mm)	B	23	29	35	45	55	65	73	92	92	120	135	152
Actuation ring Ø ("F" Version) (mm)	B ^F	24	32	42	51.5	62	70	83	98	98	132	155	177
Clamping fit length C ₁ /C ₂ (mm)	C ₁ /C ₂	14 11	16 13	19 16	21 16	28 22	33 27	39 31	43 35	43 35	52 42	61 52	74 48
Bore Diameter from Ø to Ø H7 (mm)	D ₁	3-8*	4-12*	5-16*	5-20*	8-22*	10-25*	12-32	14-38*	14-38*	30-56	35-60	40-62*
Bore Diameter from Ø to Ø H7 (mm)	D ₂	3-8*	4-12*	5-14*	5-20*	8-26	10-30	12-32	14-42	14-42	30-60	35-60	40-75
Diameter (mm)	D ₃	9.1	12.1	14.1	20.1	21.1	24.1	32.1	36.1	36.1	58.1	60.1	60.1
Outside diameter (mm)	E	19	25	32	40	49	55	66	81	81	110	123	134
Distance (mm)	F	12	13	15	17	19	24	28	31	31	35	45	50
Distance ("F" Version) (mm)	F ^F	11.5	12	14	16	19	22	29	31	30	36	43	54
Distance (mm)	G	3.5	4	5	5	6.5	7.5	9.5	11	11	13	17	18
Distance between centers (mm)	H	6	8	10	15	17	19	23	27	27	39	41	2x48
Screw ISO 4762	I	M2.5	M3	M4	M4	M5	M6	M8	M10	M10	M12	M16	2xM16
Tightening torque (Nm)	I	1	2	4	4.5	8	15	40	50	70	130	200	250
Pretensioning, approx (mm)	K	0.1-0.5	0.2-0.7	0.2-0.7	0.2-1.0	0.2-1.0	0.3-1.5	0.5-1.5	0.5-1.0	0.5-1.0	0.5-1.5	0.5-2.0	0.8-2.0
Axial recovery of coupling max. (N)	K	4	8 5	15 10	25 30	20 12	50 30	70 45	48 32	82 52	157 106	140 96	200
Approx. weight (kg)		0.038	0.07	0.2	0.3	0.4	0.6	1.4	2	2.4	5.9	9.6	15
Moment of inertia (10 ⁻³ kgm ²)	J _{ges}	0.01	0.01 0.01	0.02 0.02	0.06 0.07	0.10 0.15	0.27 0.32	0.75 0.80	1.80 1.90	2.50 2.80	6.50 7.00	13.0 17.0	50
Torsional stiffness (10 ³ Nm/rad)	C _T	0.7	1.2 1.3	7 5	8 7	12 10	18 16	40 31	68 45	90 60	220 190	260 250	390
Lateral ± (mm)	max. values	0.15	0.15 0.20	0.20 0.25	0.20 0.30	0.15 0.20	0.20 0.25	0.20 0.25	0.20 0.25	0.20 0.25	0.25 0.30	0.30 0.35	0.35
Angular ± (Degree)	values	1	1 1.5	1.5 2	1.5 2	1 1.5	1 1.5	1 1.5	1 1.5	1 1.5	1.5 2	2 2.5	2.5
Lateral spring stiffness (N/mm)		70	40 30	290 45	280 145	475 137	900 270	1200 420	920 290	1550 435	3750 1050	2500 840	2000
Actuation distance (mm)		0.7	0.8	0.8	1.2	1.5	1.5	1.7	1.9	1.9	2.2	2.2	2.2

A^F, B^F, L^F = Full disengagement / manual re-engagement version (F)

* keyway with max. bore only conditionally possible.

PROPERTIES

MATERIAL

- ▶ **Clutch system:** hardened steel
- ▶ **Hub D1:** up to size 450 high strength aluminum, size 800 and up steel
- ▶ **Hub D2:** up to size 60 high strength aluminum, size 150 and up steel
- ▶ **Elastomer insert:** wear resistant thermally stable TPU

DETAILS FOR ELASTOMER INSERTS
see page 66/67

DESIGN

Two clamping hubs with one clamping

screw in each and concave driving jaws. Backlash free, vibration damping, electrically isolating elastomer insert press fit into the jaw sets. Clutch system: spring loaded ball-detent principle.

AVAILABLE FUNCTION SYSTEMS

- ▶ **W** = Single position / automatic re-engagement (standard)
- ▶ **D** = Multi-position / automatic re-engagement
- ▶ **G** = Load holding / load blocking
- ▶ **F** = Full disengagement / manual re-engagement

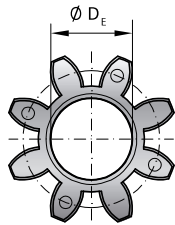

Size 5-800 elastomer insert type A / B

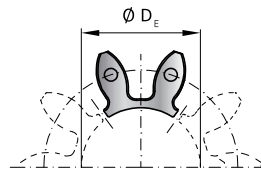

Size 1500 includes 5x elastomer segments type A / B

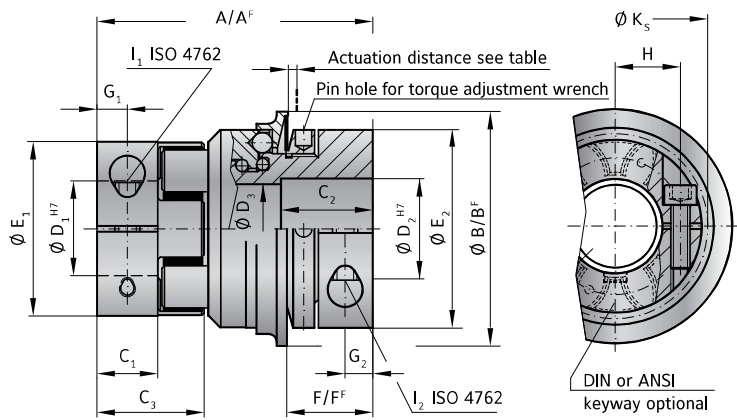

MODEL ES2

Size		5		10		20		60		150		300		450		800		1500	
Type (Elastomer insert)		A	B	A	B	A	B	A	B	A	B	A	B	A	B	A	B	A	B
Rated torque (Nm)	T_{KN}	9	12	12.5	16	17	21	60	75	160	200	325	405	530	660	950	1100	1950	2450
Max. torque* (Nm)	T_{Kmax}	18	24	25	32	34	42	120	150	320	400	650	810	1060	1350	1900	2150	3900	4900
Adjustment range possible from -to (Nm)	T_{KN}	1-3 or 3-6		2-6 or 4-12		10-25 or 20-40		10-30 or 25-80		20-70 or 45-150 or 80-180		100-200 or 150-240 or 200-320		80-200 or 200-350 or 300-500		400-650 or 500-800 or 600-900		600-850 or 700-1200 or 1000-1800	
Adjustment range ("F" Version) possible from -to (Nm)	T_{KN}^F	2.5 - 4.5		2-5 or 5-10		8-20 or 16-30		20-40 or 30-60		20-60 or 40-80 or 80-150		120-180 or 180-300		60-150 or 100-300 or 250-500		200-400 or 450-800		1000-1250 or 1250-1500	
Overall length (mm)	A	50	60	86	96	106	140	164	179	245									
Overall length ("F" Version) (mm)	A_F	50	60	86	96	108	143	168	190	257									
Actuation ring \varnothing (mm)	B	35	45	65	73	92	120	135	152	174									
Outside diameter of actuation ring ("F" Version) (mm)	B_F	42	51.5	70	83	98	132	155	177	187									
Clamping fit length (mm)	C_1	8	10.3	17	20	21	31	34	46	67									
Fit length (mm)	C_2	14	16	27	31	35	42	51	45	16									
Length of hub (mm)	C_3	16.7	20.7	31	36	39	52	57	74	120									
Inside diameter from \varnothing to \varnothing H7 (mm)	D_1	4 - 12.7**		5 - 16**		8 - 25		12 - 32		19 - 36		20 - 45		28 - 60		35 - 80		35 - 90	
Inside diameter from \varnothing to \varnothing H7 (mm)	D_2	6 - 14**		6 - 16**		12 - 30		15 - 32		19 - 42		30 - 60		35 - 60		40 - 75		50 - 80	
Diameter \varnothing (mm)	D_3	14.1	20.1	24.1	32.1	36.1	58.1	60.1	68.1										
Inside diameter (Elastomer insert) (mm)	D_E	10.2	14.2	19.2	26.2	29.2	36.2	46.2	60.5	79									
Diameter of the hub (mm)	E_1	25	32	42	56	66.5	82	102	136.5	160									
Diameter of the hub (mm)	E_2	19	40	55	66	81	110	123	132	157									
Distance (mm)	F	15	17	24	28	31	35	45	50	63									
Distance ("F" Version) (mm)	F_F	14	16	22	29	30	35	43	54	61									
Distance (mm)	G_1	4	5	8.5	10	11	15	17.5	23	36									
Distance (mm)	G_2	5	5	7.5	9.5	11	13	17	18	22.5									
Distance between centers (mm)	H_1	8	10.5	15	21	24	29	38	50.5	2x 57									
Screws (ISO 4762)	I_1	M3	M4	M5	M6	M8	M10	M12	M16	2x M16									
Tightening torque (Nm)		2	4.5	8	15	35	70	120	290	300									
Distance between centers D2 side (mm)	H_2	10	15	19	23	27	39	41	48	2x 55									
Screws (ISO 4762)	I_2	M4	M4	M6	M8	M10	M12	M16	2x M16	2x M20									
Tightening torque (Nm)		4	4.5	15	40	70	130	200	250	470									
Diameter with screwhead (mm)	K_S	25	32	44.5	57	68	85	105	139	155									
Approx. weight (kg)		0.2	0.3	0.6	1.0	2.4	5.8	9.3	14.3	26									
Moment of inertia (10^{-3} kgm ²)	J_{Sens}	0.02	0.06	0.25	0.7	2.3	11	22	33.5	185									
Actuation distance (mm)		0.8	1.2	1.5	1.7	1.9	2.2	2.2	2.2	3.0									

For information on shaft misalignment, torsional stiffness, and other details about the elastomer inserts see page 105. A^F, B^F, F^F = Full disengagement / manual re-engagement version (F)

* Maximum transmittable torque of the clamping hub depends on the bore diameter see table on page 70.
** keyway with max. bore only in clamping hub possible.



BACKLASH FREE TORQUE LIMITERS TORQLIGHT® 0.1 - 2,800 Nm

LIGHTWEIGHT DESIGN



GENERAL INFORMATION ABOUT R+W SAFETY COUPLINGS:



SERVICE LIFE

As long as the technical limits are not exceeded these couplings are wear and maintenance free.

FIT CLEARANCE

Overall shaft / hub clearance of 0.01 - 0.05 mm

DESIGN

In lightweight design

SPECIAL SOLUTIONS

Various materials, tolerances, dimensions and performance ratings available for custom applications on request.

ATEX (Optional)

For use in hazardous zones 1/21 and 2/22, these safety couplings have been authorized under directive 94/9/EG and are available with certification.

SLN

WITH CLAMPING COLLAR 10 - 700 Nm

PROPERTIES

DESIGN

With clamping collar and a single clamping screw.
Clutch system: spring loaded ball-detent principle. Operable temperature range from -30 to +120° C.

AVAILABLE FUNCTION SYSTEMS

- ▶ W = Single position / automatic re-engagement (standard)
- ▶ D = Multi-position / automatic re-engagement

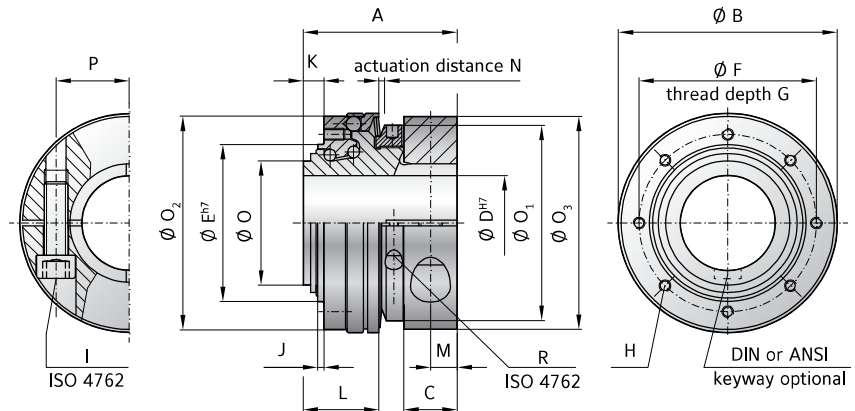

MODEL SLN

SIZE			30	60	150	300
Adjustment range* from - to	(Nm)	T _{KN}	10-35 30-80 40-135	30-80 60-120 100-200	40-100 100-200 150-300	200-350 300-450 400-550 550-700
Overall length	(mm)	A	45	53	63	72
Actuation ring Ø	(mm)	B	63	74	92	118
Clamping fit length	(mm)	C	15	18	22	24
Bore diameter from Ø to Ø H7	(mm)	D	12-30	16-35	19-42	22-60
Pilot diameter h7	(mm)	E	43	53	68	85
Bolt-hole circle diameter ± 0.2	(mm)	F	48	60	75	95
Thread depth +1	(mm)	G	5	6	7	9
Fastening threads		H	8x M4	8x M4	8x M5	8x M6
Screw ISO 4762		I	M6	M8	M10	M12
Tightening torque	(Nm)		15	40	75	130
Centering length -0.2	(mm)	J	2	2	3	3
Distance	(mm)	K	6	7	9	9
Distance to actuation ring edge	(mm)	L	23	26	32	36
Distance	(mm)	M	7.5	9	11	12
Actuation distance	(mm)	N	1.3	1.5	1.8	2
Ø Base element	(mm)	O	35	42	54	70
Ø Adjustment nut	(mm)	O ₁	55	66	82	100
Ø Flange -0.2	(mm)	O ₂	58	72	87	110
Ø Clamp ring	(mm)	O ₃	59	72	90	114
Distance between centers	(mm)	P	21.5	25	33	41
Adjustment nut's clamp screw ISO 4762		R	M3	M3	M3	M4
Tightening torque	(Nm)		2	2	2	4.5
Approx. weight	(kg)		0.3	0.5	0.8	1.5
Approx. moment of inertia at D max	(10 ⁻³ Kg·m ²)	J _{ges}	0.15	0.3	1	3

*Maximum transmittable torque of the clamping hub depends on the bore diameter / see table below

MAXIMUM TRANSMITTABLE TORQUE IN RELATION TO BORE DIAMETER

SIZE	Ø 12	Ø 15	Ø 20	Ø 25	Ø 30	Ø 35	Ø 40	Ø 45	Ø 50	Ø 55	Ø 60
30	30	55	80	110	130						
60		80	120	160	200	220					
150			200	250	300	350	400	450			
300				350	430	510	590	670	750	830	910

Higher torque possible with keyway.

SLP

WITH KEYWAY CONNECTION

10 - 700 Nm



PROPERTIES

DESIGN
 With DIN 6885 or ANSI B17.1 keyway.
 Clutch system: spring loaded ball-detent principle. Operable temperature range from -30 to +120° C.

AVAILABLE FUNCTION SYSTEMS

- ▶ W = Single position / automatic re-engagement (standard)
- ▶ D = Multi-position / automatic re-engagement

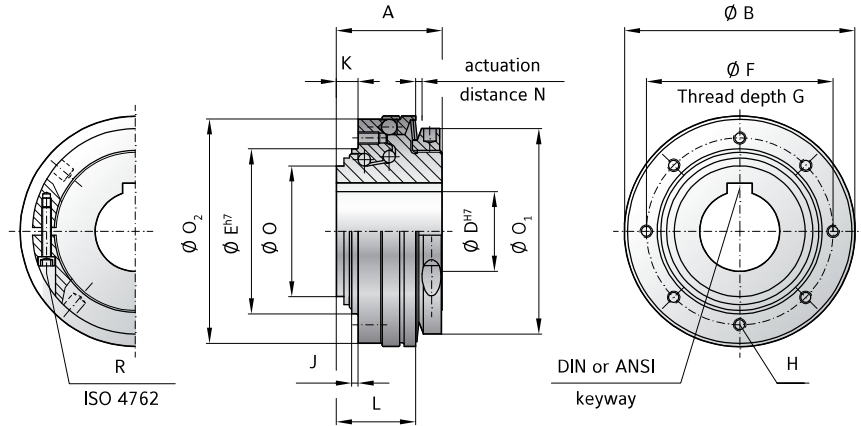

MODEL SLP

SIZE			30	60	150	300
Adjustment range* from - to	(Nm)	T _{KN}	10-35 30-80 40-135	30-80 60-120 100-200	40-100 100-200 150-300	200-350 300-450 400-550 550-700
Overall length	(mm)	A	30	35	41	48
Actuation ring diameter	(mm)	B	63	74	92	118
Bore diameter from Ø to Ø H7	(mm)	D	12-25.4 (28)*	16-30 (32)*	19-44 (46)*	22-54 (58)*
Pilot diameter h7	(mm)	E	43	53	68	85
Bolt-hole circle diameter ± 0.2	(mm)	F	48	60	75	95
Thread depth +1	(mm)	G	5	6	7	9
Fastening threads		H	8x M4	8x M4	8x M5	8x M6
Centering length -0.2	(mm)	J	2	2	3	3
Distance	(mm)	K	6	7	9	9
Distance to actuation ring edge	(mm)	L	23	26	32	36
Actuation distance	(mm)	N	1.3	1.5	1.8	2
Ø Base element	(mm)	O	35	42	54	70
Ø Adjustment nut	(mm)	O ₁	55	66	82	100
Ø Flange -0.2	(mm)	O ₂	58	72	87	110
Adjustment nut's clamp screw ISO 4762		R	M3	M3	M3	M4
Tightening torque	(Nm)		2	2	2	4.5
Approx. weight	(kg)		0.2	0.35	0.7	1.1
Approx. moment of inertia at D max.	(10 ⁻³ kgm ²)	J ₈₈₅	0.1	0.4	1.1	2.3

* maximum bore diameters shown are only available with shallow keyway according to DIN 6885/3 or special heights for inch bores

ORDERING EXAMPLE	SLN SLP	60	W	25.4	80	60-120	XX
Model	●						Special designation only (e.g. special bore / keyway dimensions).
Size		●					
Function system			●				
Bore D H7				●			
Disengagement torque Nm					●		
Torque adjustment range Nm						●	
For custom features place an XX at the end of the part number and describe the special requirements (e.g. SLN / 60 / W / 25.4 / 80 / 60-120; XX=special dual keyway)							

SL2

WITH CLAMPING HUBS

10 - 400 Nm



PROPERTIES

DESIGN

Clamping collar / clamping hub with one clamping screw each. Clutch system: spring loaded ball-detent principle. Special compact, high stiffness version. Operable temperature range from -30 to +100° C.

AVAILABLE FUNCTION SYSTEMS

- ▶ W = Single position / automatic re-engagement (standard)
- ▶ D = Multi-position / automatic re-engagement

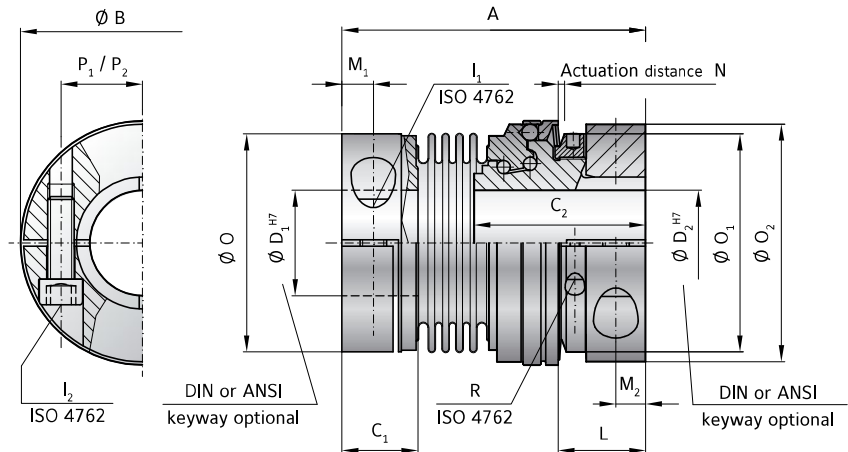

MODEL SL2

SIZE			30	60	150	300
Adjustment range* from - to	(Nm)	T_{KN}	10-35 30-80	20-50 40-100	40-100 100-200	100-250 200-350 300-400
Overall length	(mm)	A	80	93	112	126
Actuation ring diameter	(mm)	B	63	74	92	118
Hub length	(mm)	C_1/C_2	21/45	23/53	28 / 63	34/72
Bore diameter from \emptyset to \emptyset H7	(mm)	D_1/D_2	12-32/12-30	16-35 / 16-35	19-42 / 19-42	22-60 / 22-60
Screw ISO 4762	(mm)		M6	M8	M10	M12
Tightening torque	(Nm)	I_1/I_2	15	40	75	130
Distance to actuation ring edge	(mm)	L	22	26	32	35
Distance	(mm)	M_1/M_2	7.5/7.5	9.5/9	11/11	13/12
Actuation distance	(mm)	N	1.3	1.5	1.8	2
\emptyset Clamping hub \emptyset , (coupling end)	(mm)	O	55.5	66	82	110
\emptyset Adjustment nut	(mm)	O_1	55	66	82	100
Clamping ring \emptyset , (torque limiter end)	(mm)	O_2	59	72	90	112
Distance between centers, bellows side/safety element	(mm)	P_1/P_2	20/21.5	23 / 25	27/33	39/41
Adjustment nut's clamp screw ISO 4762			M3	M3	M3	M4
Tightening torque	(Nm)	R	2	2	2	4.5
Approx. weight	(kg)		0.4	0.7	1.2	2.8
Approx. moment of inertia at D max. (10^{-3} Kgm ²)		J_{ges}	0.2	0.8	1.4	6.2
Torsional stiffness (10^3 Nm/rad)			31	72	141	157
Lateral \pm max. (mm)			0.2	0.2	0.2	0.25

*Maximum transmittable torque of the clamping hub depends on the bore diameter / see table on page 103

ORDERING EXAMPLE	SL2 SK2	60	W	30	20	80	40-100	XX
Model	●							Special designation only (e.g. special bore / keyway dimensions).
Size		●						
Function system			●					
Bore D1 H7				●				
Bore D2 H7					●			
Disengagement torque Nm						●		
Torque adjustment range Nm							●	
For custom features place an XX at the end of the part number and describe the special requirements (e.g. SL2 / 60 / W / 30 / 20 / 80 / 40-100; XX=special dual keyway)								



PROPERTIES

DESIGN

Clamping collar with clamping screw. Clamping hub with concave driving jaws and clamping screw. Backlash free, vibration damping, electrically isolating elastomer insert press fit into the jaw sets. Clutch system: spring loaded ball-detent principle, in a special compact, low inertia design.

AVAILABLE FUNCTION SYSTEMS

- ▶ W = Single position / automatic re-engagement (standard)
- ▶ D = Multi-position / automatic re-engagement

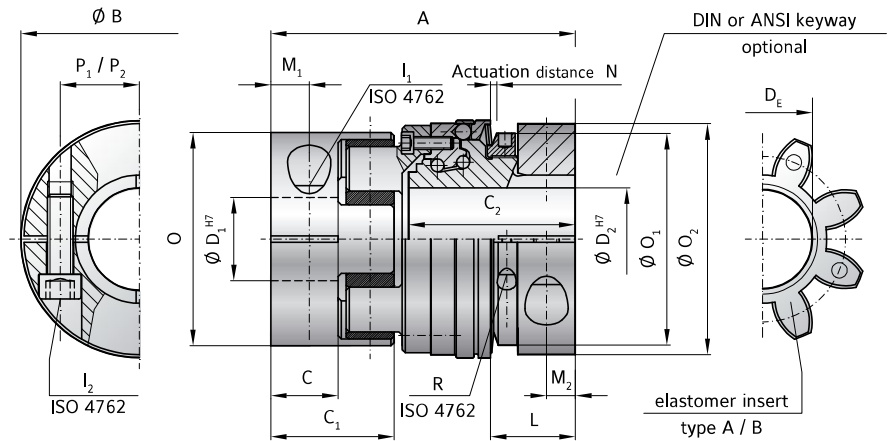

MODEL SLE

SIZE		30		60		150		300	
Type (elastomer insert)		A	B	A	B	A	B	A	B
Rated torque	T_{KN}	60	75	160	200	325	405	530	660
Max. torque	$T_{KN max}$	120	150	320	400	650	810	1060	1350
Adjustment range* possible from -to	(Nm) T_{KN}	10-35 30-80 40-135		30-80 60-120 100-200		40-100 100-200 150-300		200-350 300-450 400-550 550-700	
Overall length	(mm) A	85		93		122		135	
Actuation ring diameter	(mm) B	63		74		92		118	
Hub length (coupling hub end)	(mm) C/C ₁	20 / 36		21 / 39		31 / 52		34 / 57	
Length of hub (torque limiting portion)	(mm) C ₂	45		53		63		72	
Bore diameter from Ø to Ø H7	(mm) D ₁ /D ₂	12-32 / 12-30		16-36 / 16-35		19-45 / 19-42		22-60 / 22-60	
Inner diameter (elastomer insert)	(mm) D _ε	26.2		29.2		36.2		46.2	
ISO 4762 screw, coupling side / torque limiter side	I ₁ /I ₂	M6		M8		M10		M12	
Tightening torque	(Nm)	15		40		75		130	
Distance to actuation ring edge	(mm) L	22		26		32		35	
Distance	(mm) M ₁ /M ₂	10 / 7.5		12 / 9		15 / 11		17.5 / 12	
Actuation distance	(mm) N	1.3		1.5		1.8		2	
Clamping hub Ø, elastomer coupling	(mm) O	56		66.5		82		102	
Ø Adjustment nut	(mm) O ₁	55		66		82		100	
Clamping hub Ø, safety coupling	(mm) O ₂	59		72		90		112	
Distance to clamping screw, coupling side / torque limiter side	(mm) P ₁ /P ₂	21 / 21.5		24 / 25		29 / 33		38 / 41	
Adjustment nut's clamp screw ISO 4762	R	M3		M3		M3		M4	
Tightening torque	(Nm)	2		2		2		4.5	
Approx. weight	(kg)	0.4		0.8		1.5		2.9	
Approx. moment of inertia at D max.(10 ⁻³ Kg·m ²)	J _{ges}	0.3		1		1.8		5	
Static torsional rigidity	(Nm/rad)	3290	9750	4970	10600	12400	18000	15100	27000
Dynamic torsional rigidity	(Nm/rad)	7940	11900	13400	29300	23700	40400	55400	81200
Lateral ±	approx. (mm)	0.12	0.1	0.15	0.12	0.18	0.14	0.2	0.18



PROPERTIES

MATERIAL

- **Clutch system:** high strength steel, drive balls made from hardened steel
- **Hubs:** high strength aluminum
- **Elastomer insert:** wear resistant, thermally stable TPU

DESIGN

Two hubs, each with keyway, set screw, and concave driving jaws. The clutch system is integrated into one of the hubs.

DISENGAGEMENT

Negligible wear at up to 200 rpm. Contact R+W for higher speed applications.

DETAILS FOR ELASTOMER INSERT see page 66/67

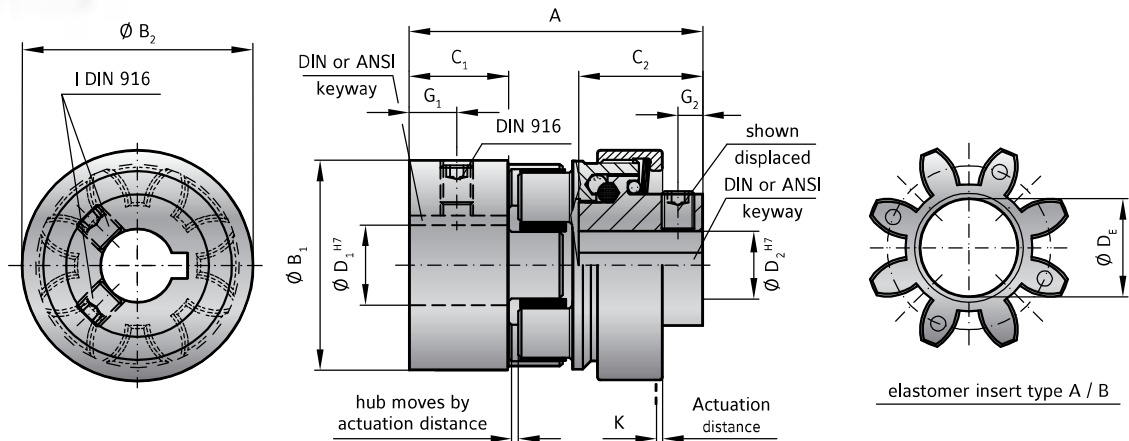

MODEL ESL

Size	5		10		20		60		150	
Type (Elastomer insert)	A	B	A	B	A	B	A	B	A	B
Rated torque (Nm) T_{kn}	9	12	12.5	16	17	21	60	75	160	200
Torque setting possible* from - to (Nm) T_{kn}	1-6		1-12		3-19		5-60		20-150	
Overall length (mm) A	34		45		64		80		90	
Diameter of the hub (mm) B_1	25		32		42		56		66.5	
Diameter of the hub (mm) B_2	29		32		46		59		75	
Clamping fit length (mm) C_1	12.5		12		25		30		35	
Clamping fit length (mm) C_2	11.5		20		22		31		35	
Inside diameter from \varnothing to $\varnothing H7$ (mm) D_1	6-15		6-18		8-25		12-32		19-38	
Inside diameter from \varnothing to $\varnothing H7$ (mm) D_2	6-10		6-12		8-19		12-24		19-32	
Inside diameter max. (elastomer) (mm) D_e	10.5		14.2		19.2		26.2		29.2	
Distance (mm) G_1	5		6		9		11		12	
Distance (mm) G_2	2.5		3.5		4		4		4	
Screws DIN 916**	I depending on bore diameter see below table									
Approx. weight (kg)	0.05		0.15		0.2		0.5		1	
Moment of inertia (10^{-3} kgm^2) J_1/J_2	0.01		0.02		0.08		0.15		0.5	
Actuation distance (mm) K	0.6		0.6		0.7		1.1		1.4	

* Disengagement torque is permanently set at the factory. For information on shaft misalignment, torsional stiffness, and other details about the elastomer inserts see page 70.

ORDERING EXAMPLE	ESL	10	A	14	12	10	XX
Model	●						Special designation only (e.g. special bore tolerance).
Size		●					
Elastomer insert type			●				
Bore D1 H7 includes standard keyway				●			
Bore D2 H7 includes standard keyway					●		
Disengagement torque Nm (not adjustable)						●	
For custom features place an XX at the end of the part number and describe the special requirements (e.g. ESL / 10 / A / 14 / 12 / 10 / XX; XX=stainless steel)							

FIXED DISENGAGEMENT TORQUE

The ESL coupling is unlike other R+W safety couplings in that the disengagement torque is permanently set and tamper proof.

** SET SCREWS

D1/D2	- \varnothing 10	\varnothing 11-12	\varnothing 13-30	\varnothing 31-58	\varnothing 59-80
I	M3	M4	M5	M8	M10

Bores <6mm made without keyway.



TORQUE LIMITERS ACCESSORIES



ACCESSORIES FOR SK / ES2 / SL TORQUE LIMITERS

It is important that switches are 100% tested for proper functioning after mounting.

PROXIMITY SWITCH (E-STOP FUNCTION)

SK ES2

ORDER NUMBER 650.2703.001

TECHNICAL DATA	SK, ES2
Voltage	10 to 30 V DC
Max. output current	200 mA
Max. switch frequency	800 Hz
Temperature range	-25° to +70° C
Protective system	IP 67
Switch type	normally open
Max. detection gap	max. 2 mm
SWITCH DIAGRAM SK, ES2	

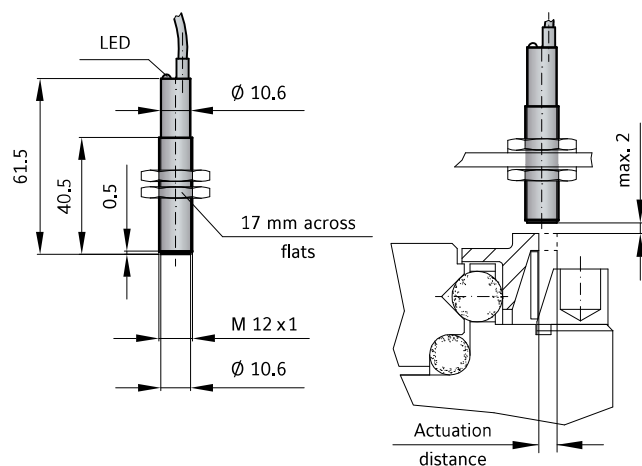

SL

ORDER NUMBER 619.4711.650

TECHNICAL DATA	SL
Voltage	10 to 30 V DC
Max. output current	200 mA
Max. switch frequency	≤ 3 KHz
Temperature range	-25° to +70° C
Protective system	IP 67
Switch type	PNP, NO
Max. detection gap	max. 2 mm
SWITCH DIAGRAM SL	

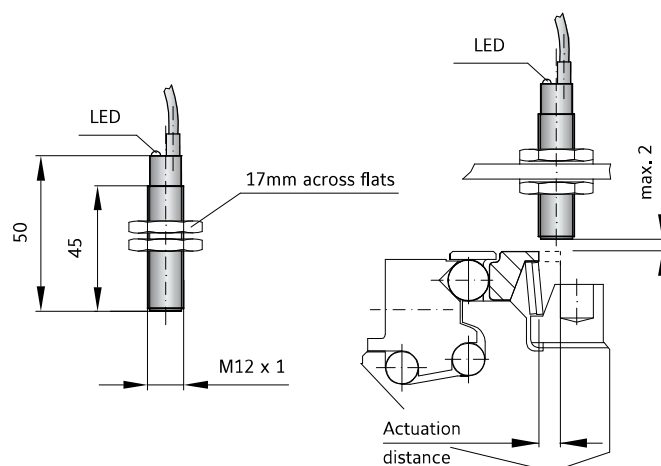

It is important that switches are 100% tested for proper functioning after mounting.

MECHANICAL LIMIT SWITCH (E-STOP FUNCTION)

SK

ES

SL

ORDER NUMBER 618.6740.644

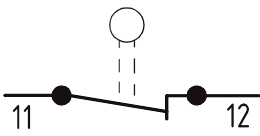
TECHNICAL DATA	SK, ES2, SL
Max. voltage	250 V AC
MAX. CONSTANT CURRENT:	10h A
Protective system	IP 65
Contact system	Opener (forced seperating)
Temperature range	-30° to +80° C
Actuation	Plunger (metal)
SWITCH DIAGRAM SK, ES2, SL	
	

The mechanical limit switch is suitable for size 30 and up. For smaller safety couplings the proximity sensor is recommended.

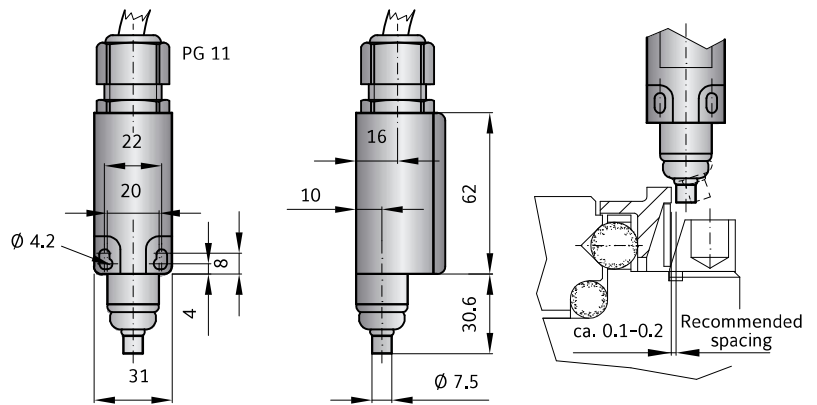

The switch plunger (pictured above and right) should be located as close to the actuation ring / limit switch plate as possible (approximately 0.1-0.2mm).

ACCESSORIES FOR ATEX TORQUE LIMITERS

It is important that switches are 100% tested for proper functioning after mounting.

ATEX PROXIMITY SWITCH (E-STOP FUNCTION)

SK **ES2**

ORDER NUMBER EEX. 1624.004

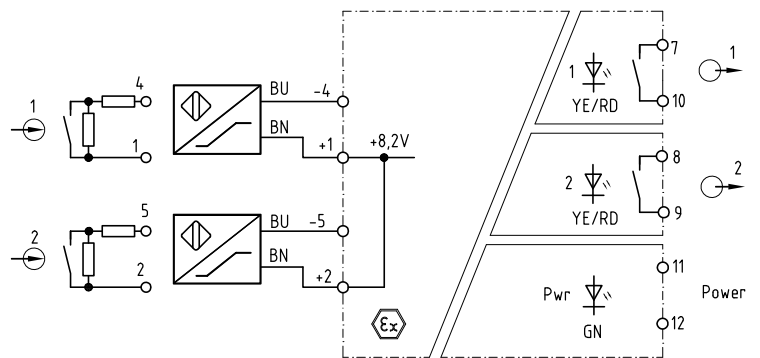
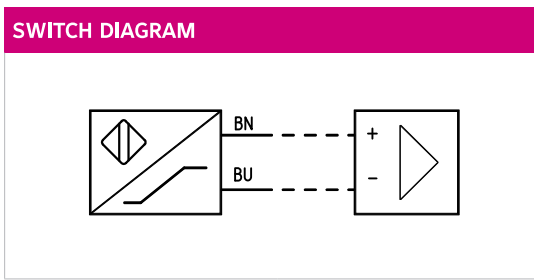
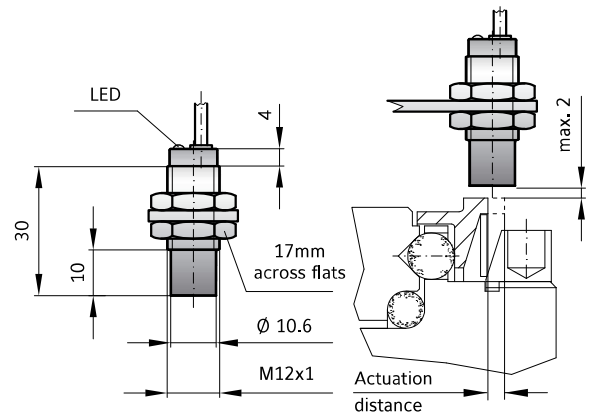
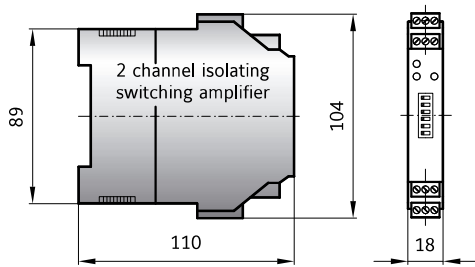

ACCESSORIES FOR SK/ES2/SL TORQUE LIMITERS

R+W SPANNER WRENCH FOR TORQUE ADJUSTMENT



For smaller couplings the spanner wrench is not necessary. In sizes 1.5/2/4.5/10 the torque adjustment nut is easily turned with a screw or pin.

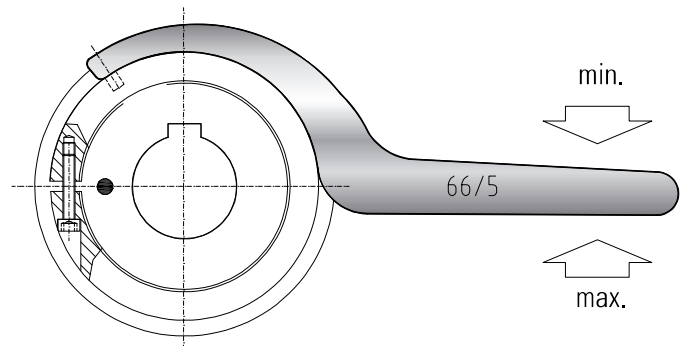

ORDER NUMBERS

COUPLING SIZE	SK Single position Multi-position Load holding	SK Full disengagement	ES2 Single position Multi-position Load holding	ES2 Full disengagement	SL Single position Multi-position
15	49/4	49/4	-	-	-
20	-	-	55/4	55/4	-
30	55/4	55/4	-	-	55/4
60	66/5	66/5	66/5	66/5	66/5
80	82/5	82/5	-	-	-
150	82/5	82/5	82/5	82/5	82/5
200	90/6	98/5	-	-	-
300	114/6	114/6	114/6	114/6	100/6
450	-	-	126/8	126/8	-
500	126/8	126/8	-	-	-
800	134/8	144/8	134/8	144/8	-
1500	163/8	163/8	163/8	163/8	-
2500	210/10	226/10	-	-	-