

# Conveyors C

Vacuum is used with great advantage in order to convey dry powder products through dedicated pipe systems. PIAB's vacuum conveying systems are built of strong components of high quality. Our objective is to offer solutions that help our customers raise their productivity. Production of food, pharmaceuticals and chemical products demands the highest possible degree of safety as to hygiene and operation. PIAB's new series of vacuum conveyors has been developed as an answer to the severe requirements of operational safety and hygiene in the food, pharmaceutical and chemical industries.

<b>PIAB CONVEYORS C, INTRODUCTION</b>	41
<b>ADVANTAGES WITH PIAB CONVEYORS C</b>	42
<b>WE TEST YOUR POWDERS</b>	43
<b>SELECTING A CONVEYOR</b>	44
<b>HOW TO ORDER</b>	46
<b>CONVEYORS C</b>	
Complete	48
Conveyors C21	90
Conveyors C33	124
Conveyors C56	152
Control Units	188
Modules	203
Accessories	214

**Vacuum conveying – an ingenious way of moving powders and granules.**

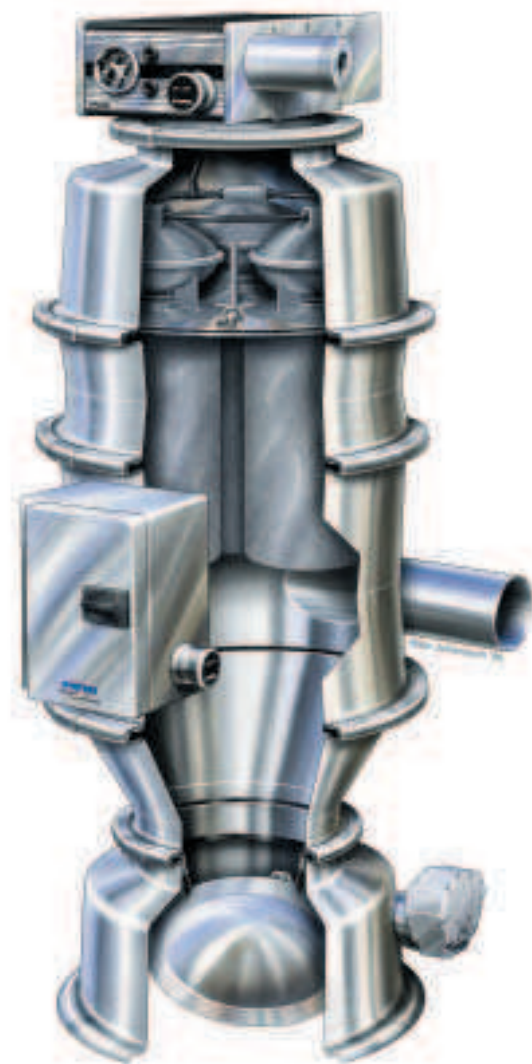

**PIAB's vacuum pumps are the heart of the vacuum conveying system.**

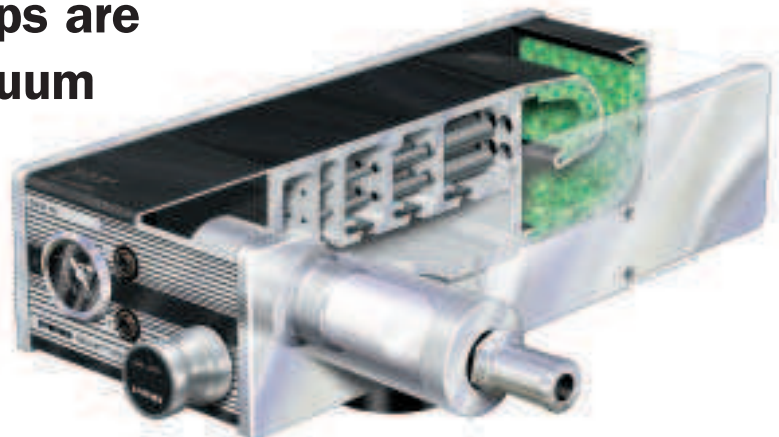

## PIAB CONVEYORS C, MODELS C21, C33 AND C56

### TAKE A LEAP AHEAD OF THE CROWD!

Vacuum can be used at great advantage to convey dry powder products in exclusively designed pipe systems. Production of foodstuff, pharmaceutical and chemical products demands the highest possible safety in terms of hygiene and operation. PIAB's new series of vacuum conveyors have been developed to meet the strict demands of operational safety and hygiene in the food, pharmaceutical and chemical industries. USDA – United States Department of Agriculture, has examined some of our models and therefore these conveyors meet the requirements of the guidelines for handling of dairy products. Through this, the conveyors also conform to the hygienic standards implemented by organizations such as 3-A Sanitary Standards and EHEDG – European Hygiene Engineering Design Group. For further information on the above-mentioned organizations, please see the special chapter further back in the catalogue.



*USDA spans the distance from the farm to your table!*

### INCREASE YOUR PRODUCTIVITY

- ▶ Optimized design for highest possible hygiene.
- ▶ Few moving parts to ensure a minimum of maintenance.
- ▶ Easy to disassemble/assemble and clean.
- ▶ Modular design for easy adaptation to your unique production environment.
- ▶ USDA – Hygienic safety.
- ▶ FDA – Material used is in accordance with the requirements of FDA.
- ▶ 3-A – Hygienic safety.
- ▶ EHEDG – Hygienic safety.
- ▶ GMP – Hygienic safety.
- ▶ PIAB's vacuum pumps for high operational safety and low energy consumption.
- ▶ Designed for the food and pharmaceutical industries.
- ▶ Steel quality ASTM 316L – Market requirement.

## ADVANTAGES WITH PIAB CONVEYORS C

### PERFECT FOR POWDERS AND GRANULES

Industries that produce foodstuff, pharmaceuticals and chemical products have discovered the advantages of vacuum conveying. PIAB, which has developed vacuum conveying systems for 30 years, is the leader of the industry. We provide the solutions to your conveying problems!



*In manual handling the operators are subjected to heavy lifts and dusty premises.*

### FRIENDLY – BOTH TO YOUR HEALTH AS WELL AS TO THE ENVIRONMENT

Different powders require different vacuum levels in order to be conveyed. With PIAB conveyors C you just set the energy consumption exactly according to the prevailing conditions.

### FROM 0 TO 20 METRES IN ONE SECOND

Time is money. The vacuum technology offers you powder conveying at express speed. Up to 30-metre long systems, the sum of vertical and horizontal conveying.

### 15 TONS PER HOUR

15 tons per hour have been measured at short distance tests with a PIAB conveyor C under favourable conditions.



*In a vacuum conveying system, the conveying is fully sealed off from the surrounding environment, which means a working environment without heavy lifting, dust or other contaminations.*

### EASY TO INSTALL ANY PLACE

Our systems can be easily adapted to your production environment thanks to few components, small dimensions and low weight. The modular system facilitates the installation. The basic unit is delivered on a turn-key basis. You just have to connect compressed air!

### DURABLE MATERIAL

The conveyors C are made of stainless, highly polished steel (ASTM 316L). The material is acid-proof and has very strong characteristics. We offer a full 5-year guarantee (filter and wear parts excluded.)

### RELIABLE AND EASY TO MAINTAIN

Our systems require a minimum of maintenance. They are easy to clean, and filter cleaning is automatic. Operation and control are fully pneumatic in standard design.

### OPERATIONAL SAFETY

The design of the conveyor and PIAB's vacuum pumps offers the highest possible operational safety.

### HYGIENE

The conveyors C are, first and foremost, adapted to the food and pharmaceutical industries.

## WE TEST YOUR POWDERS

In our test facility different conveying distances and materials are tested in order to simulate your requirements and applications. The test results are available at your PIAB distributor. You can rest assured to get the optimum dimensioning of your installation, as well as the proper accessories and control system. PIAB is always nearby as PIAB is located all over the world with test center facilities in Asia, North America and in Europe.



Test facility at PIAB AB, Sweden.



Test facility at PIAB USA, Inc. USA.



Test facility at PIAB Japan Ltd, Japan.



Test facility at PIAB Vakuum AG, Switzerland.

Conveyors C

### EXAMPLE OF MATERIALS THAT HAVE BEEN TESTED BY PIAB

We can convey all sorts of products; fine powder, granules, dry, wet, sticky, dusty etc. Below is a short list showing examples of materials which have been tested in our test facilities.

Ask your nearest distributor for questions about your material. To find your local distributor, please visit [www.piab.com](http://www.piab.com) or see the back cover of this catalogue.

Consumer/food	Pharma/chemical	Others
Cereal	Capsule	Aluminium oxide
Cheese powder	Carbon, activated	Bronze (granules, powder)
Cocoa (powder, beans)	Clay powder	Calcium chloride
Coffee (ground and beans)	Cobalt	Glue tablets
Detergent	Corn flour	Gun powder
Egg yolk powder	Gelatine powder	Limestone
Milk powder	Glass blast powder	Pet food (pellets)
Rice, puffed	Plastic granules	Sand
Sugar (granulated, icing)	PVC powder	Saw dust
Tea	Silica gel	Silicium carbide
Wheat flour	Tablets	Talcum
Yeast	Titanium	Wood flour

## SELECTING A CONVEYOR

### EXAMPLE OF CONVEYORS

Model	Pm figures
C2100-64	1-2
C2101-100	3-5
C2102-100	3-5
C2104-200	5-10
C2102S-100	3-5
C2104S-200	5-10
C3302-400	10-20
C3304-400	10-20
C3304-600	20-30
C3306-600	20-30
C3306-800	30-40
C3302S-400	10-20
C3304S-400	10-20
C3304S-600	20-30
C3306S-600	20-30
C3306S-800	30-40
C5602-800	30-40
C5604-800	30-40
C5604-1200	40-60
C5606-1200	40-60
C5606-1600	60-80



### PM FIGURE, CONVEYING DISTANCE AND CAPACITY

Power requirement ( $Pm$ ) is the product of the total conveying distance ( $L$ ) in metres and the capacity ( $Q$ ) in tons/hour.  $L$  = the sum of the horizontal ( $L_h$ ) and the vertical conveying distance ( $L_v$ ).

$$Pm = L \times Q$$

This applies when  $L$  is 4–30 metres, at bulk densities ( $B$ ) = 0.5–1.8 ton/m<sup>3</sup>, as well as when the particle size is < 5 mm.

When the  $Pm$  figure has been calculated, one compares the recommended  $Pm$  value in the table.

### EXAMPLE OF HOW TO SELECT A STANDARD CONVEYOR

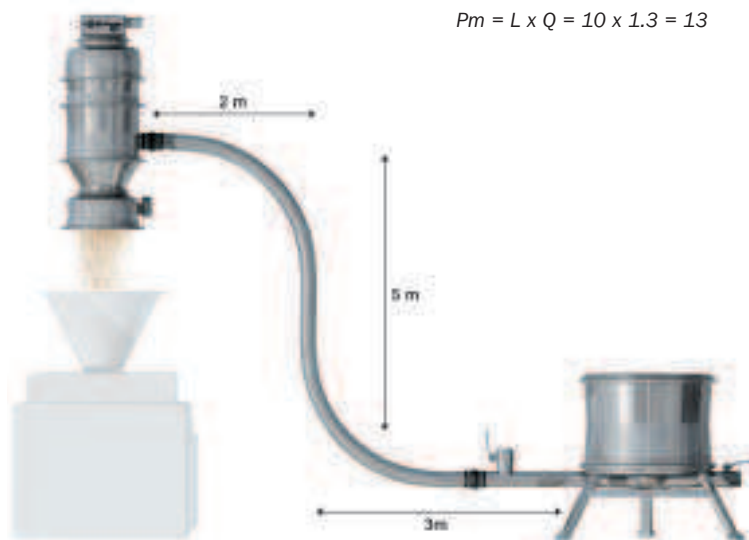

$$Pm = L \times Q = 10 \times 1.3 = 13$$

## PIPE DIMENSIONING

These recommendations apply at conveying distances  $4 < L < 30$  metres. At conveying distances  $> 30$  metres, please contact PIAB.

In the case of heavier powders with a bulk density (B)  $> 1 \text{ ton/m}^3$  smaller pipe dimensions should be chosen, and for lighter powders  $< 1 \text{ ton/m}^3$  bigger pipe dimensions should be chosen.

**NOTE!** The bends should be as few as possible and should have a radius of at least 10 pipe diameters =  $10 \times 50 = 500$  mm to make the conveying of powder run smoothly.

Model	B $> 1 \text{ ton/m}^3$	B $< 1 \text{ ton/m}^3$
C2100-64	25	25
C2101-100	32	40
C2102-200	32	40
C2104-200	32.40	51
C3302-400	40	51
C3304-400	40	51
C3304-600	51	76
C3306-600	51	76
C3306-800	51	76
C5602-800	51	76
C5604-800	51	76
C5604-1200	51.76	102
C5606-1200	51.76	102
C5606-1600	76	102

## THE CONVEYOR BUILD-UP

PIAB's conveyor C is built of different functional units, 1–5, where each unit offers a number of different choices such as filter material, gasket material, type of connection, control possibilities, etc. These choices are decisive as to how sophisticated the final function of the conveyor will be. Your PIAB distributor will be glad to help you when making your choice. PIAB's conveyors C are available in three different sizes, C21, C33 and C56.

## UNITS

Figures 1–5 below show the functional units that can be chosen.

1. Pump unit
2. Filter unit
3. Connection unit
4. Bottom valve unit
5. Control unit

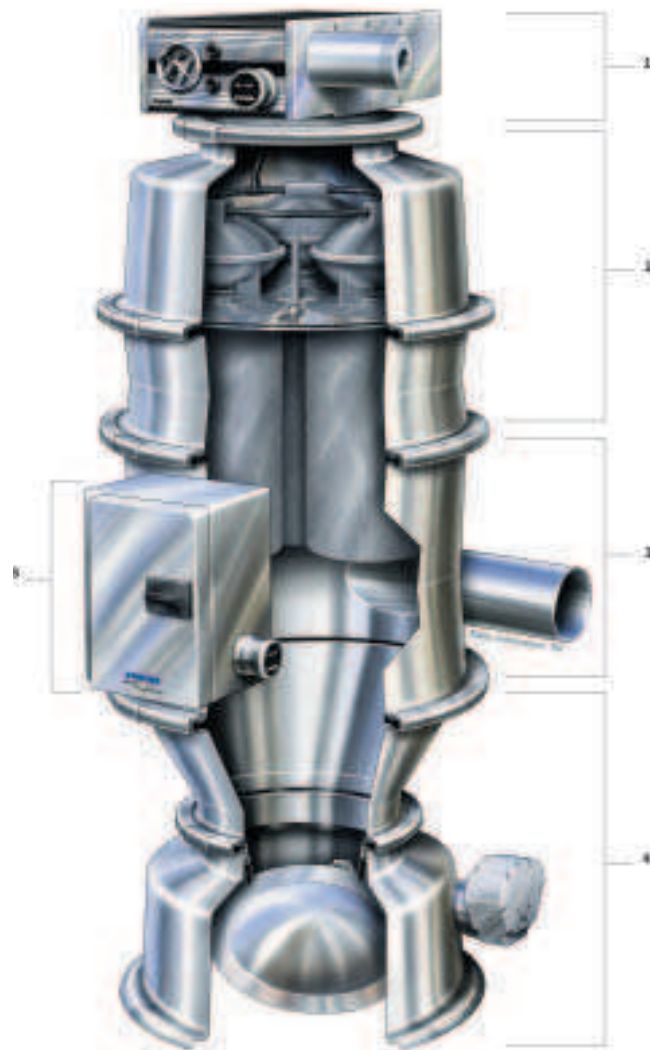

Conveyors C

## HOW TO ORDER

When building a vacuum conveyor, it is necessary to notice the following:

- Performance of the conveyor C.
- Special demands such as USDA, ATEX or FDA requirements.
- Take into consideration the material of sealings, fluid cones and type of filter.

Properties of different materials used in PIAB vacuum conveyor sealings				
	Synthetic rubber			
Term	Nitrile rubber	Silicone rubber	Fluorine rubber	Definition of numbers
<b>Notification</b>	The Nitrile rubber is designated .../1 in the PN	The Silicone rubber is designated .../2 in the PN	The Fluorin rubber is ordered separately	
<b>Abbreviation</b>	NBR	Q	FPM	<b>1</b> = Not recommended
Trade name (common)	Perbunan Krynac	Elastosil Silopren	Viton Fluorel	<b>2</b> = Moderate to severe effect. The material may be used to a certain extent in conjunction with the indicated behavior of chemicals if the contact period is short. Permanent contact will, however, destroy the material. The indicated materials have consequently a limited field of operation.
				<b>3</b> = Little to minor effect. The material will probably give satisfactory results but will sooner or later be destroyed by the indicated behavior of chemicals.
Characteristics				<b>4</b> = Recommended. The material is unlikely to be destroyed by the indicated behavior of chemicals.
<b>Colour</b>	Black	White	Green	
<b>Upper temperature limit</b>	+125 °C	+175 °C	+200 °C	
<b>Lower temperature limit</b>	-20 °C	-30 °C	-15 °C	
<b>FDA</b>	Yes	Yes	No	
<b>Antistatic</b>	Yes	No	No	
<b>Resistance to</b>				<b>Comment</b>
<b>Wear</b>	3	1	2	For more specific information about a typical material, please contact PIAB AB.
<b>Weather and ozone</b>	1	4	4	
<b>Ageing due to heat</b>	3	4	4	
<b>Hydrocarbon</b>	4	2	4	
<b>Hydrolysis</b>	4	3	4	
<b>Acids</b>	2	1	3	
<b>Basicity</b>	3	2	2	

**The capacity requirements** decide **the pump**. The pump unit is the driving force of the conveyor and is available in different sizes.

Pm figure	Pump unit	Art. No.
1-2	Pump PS6610	0117443
3-5	Pump unit Maxi L100	0106812
5-10	Pump unit Maxi L200	0103878
10-20	Pump unit Maxi L400	0103879
20-30	Pump unit Maxi L600	0103880
30-40	Pump unit Maxi L800	0103881
40-60	Pump unit Maxi L1200	0103882
60-80	Pump unit Maxi L1600	0103883



- **The material characteristics;** the characteristics of the product, such as particle size, bulk density, possible tendency to be adhesive, abrasive, etc., are, together with the pump unit, the critical point when choosing a **filter unit**.

Selection of FILTER UNIT corresponding to selected PUMP UNIT and powder PARTICLE SIZE.									
	<b>G</b> = powder with particle size >25 µm (granules) <b>P</b> = powder with particle size >10 µm <b>FP</b> = powder with particle size >5 µm <b>UFP</b> = powder with particle size >0.5 µm <b>H</b> = USDA accepted unit	Pump PS6610	Pump unit Maxi L100	Pump unit Maxi L200	Pump unit Maxi L400	Pump unit Maxi L600	Pump unit Maxi L800	Pump unit Maxi L1200	Pump unit Maxi L1600
Filter units C21	Filter unit 2100 Gore Sinbran	<b>P</b>							
	Filter unit 2101 Textile		<b>G</b>						
	Filter unit 2102 Textile		<b>P</b>	<b>G</b>					
	Filter unit 2104 Textile		<b>FP</b>	<b>P</b>	<b>G</b>				
	Filter unit 2101 Gore Sinbran		<b>P</b>	<b>G</b>					
	Filter unit 2102 Gore Sinbran		<b>FP</b>	<b>P</b>	<b>G</b>				
	Filter unit 2104 Gore Sinbran		<b>UFP</b>	<b>FP</b>	<b>P</b>				
	Filter unit 2102 Gore Sinbran, Ext.		<b>FP</b> <b>H</b>	<b>P</b> <b>H</b>	<b>G</b> <b>H</b>				
Filter unit 2104 Gore Sinbran Ext.		<b>UFP</b> <b>H</b>	<b>FP</b> <b>H</b>	<b>P</b> <b>H</b>					
Filter units C33	Filter unit 3302 Textile			<b>P</b>	<b>G</b>				
	Filter unit 3304 Textile			<b>P</b>	<b>P</b>	<b>G</b>			
	Filter unit 3306 Textile			<b>FP</b>	<b>FP</b>	<b>P</b>	<b>G</b>		
	Filter unit 3302 Gore Sinbran			<b>FP</b>	<b>P</b>	<b>G</b>			
	Filter unit 3304 Gore Sinbran			<b>UFP</b>	<b>FP</b>	<b>P</b>	<b>G</b>		
	Filter unit 3306 Gore Sinbran				<b>UFP</b>	<b>FP</b>	<b>P</b>	<b>G</b>	
	Filter unit 3302 Gore Sinbran Ext.			<b>FP</b> <b>H</b>	<b>P</b> <b>H</b>	<b>G</b> <b>H</b>			
	Filter unit 3304 Gore Sinbran Ext.			<b>UFP</b> <b>H</b>	<b>FP</b> <b>H</b>	<b>P</b> <b>H</b>	<b>G</b> <b>H</b>		
Filter unit 3306 Gore Sinbran Ext.				<b>UFP</b> <b>H</b>	<b>FP</b> <b>H</b>	<b>P</b> <b>H</b>	<b>G</b> <b>H</b>		
Filter units C56	Filter unit 5602 Textile				<b>P</b>	<b>G</b>			
	Filter unit 5602 Textile				<b>P</b>	<b>G</b>			
	Filter unit 5602 Gore Sinbran				<b>FP</b>	<b>P</b>	<b>G</b>		
	Filter unit 5602 Gore Sinbran				<b>FP</b>	<b>P</b>	<b>G</b>		
	Filter unit 5604 Textile				<b>FP</b>	<b>P</b>	<b>G</b>	<b>G</b>	
	Filter unit 5606 Textile				<b>FP</b>	<b>FP</b>	<b>P</b>	<b>P</b>	<b>G</b>
	Filter unit 5604 Gore Sinbran				<b>UFP</b>	<b>FP</b>	<b>P</b>	<b>P</b>	<b>G</b>
	Filter unit 5606 Gore Sinbran				<b>UFP</b>	<b>FP</b>	<b>FP</b>	<b>UFP</b>	<b>P</b>

- **The application** and the pipe system decide the **connection unit**.  
There are two different connection units to choose from: with or without 3-A flange on the connection pipe.
- **The material features** and application requirements are the critical point when choosing a **bottom valve unit**.  
The bottom valve unit can be delivered with various options:  
With or without fluidisation and the actuator that controls the bottom valve is available in different materials.  
Different gasket materials are chosen according to the application.
- **The complete vacuum conveying system** decides the type of **control unit**.  
The control unit is connected to the pump and the bottom flap to control these two. In the control box one starts and stops the vacuum conveyor, as well as sets the intervals that the conveyor is to convey and empty itself of powder.

## C2100-64

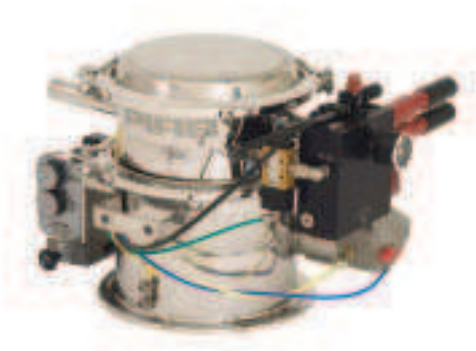

- ▶ Low building height.
- ▶ COAX® patented technology.
- ▶ Designed mainly for industries handling food, chemical and pharmaceutical products.
- ▶ Fulfils the requirements of FDA.
- ▶ Manual dismounting and cleaning.
- ▶ Gore Sinbran filter with PTFE membrane.
- ▶ Fully pneumatic.

### TECHNICAL DATA

Description	Unit	Value
Feed pressure range	MPa	0.4–0.6
Air consumption range	NI/s	2.5–3.5
Vacuum range	-kPa	61–75
Noise level range	dBA	70–73
Material		ASTM 316L, Q, SS
Temperature range	°C	0–60
Weight	kg	9.6
Filter area	m <sup>2</sup>	0.027
Material batch volume	l	1.5
Min particle size	µm	0.5

### CAPACITY

Capacity ton/h at different conveying distances	
5 m	10 m
0.35–0.50	0.20–0.25

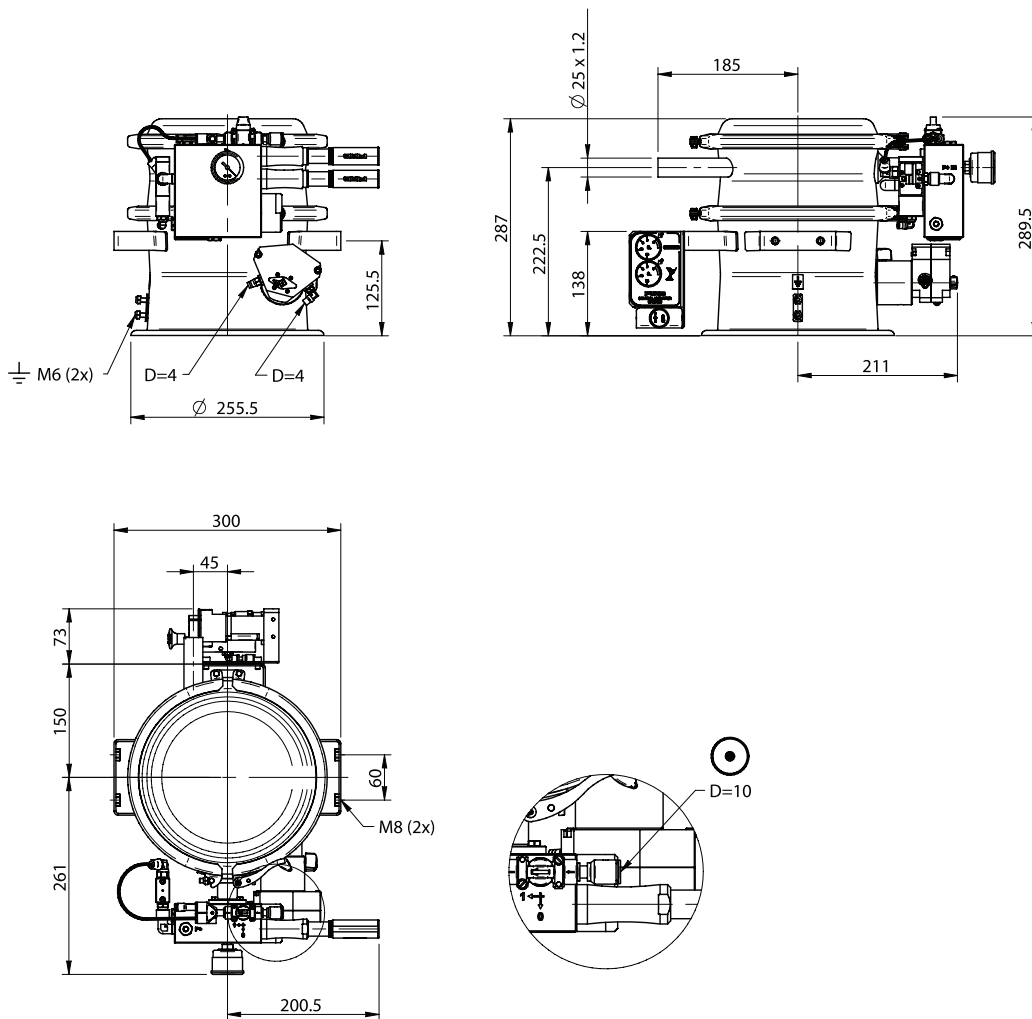

## PARTS INCLUDED

Description	Art. No.
Vacuum pump PS6610 Si32-3x2	0117443
Filter unit 2100 Gore Sinbran, Q	0117442
Bottom valve unit/module 21/16, brackets, stainless steel, Q	0117449
Control unit PPT/RS	0111636
Nylon tubing kit PPT/RS-C2100-64	0117509

## C2101-100



- ▶ Designed mainly for industries handling food, chemical and pharmaceutical products.
- ▶ Solution that contributes to dust-free conveying.
- ▶ All materials in contact with the conveyed product fulfil the requirements of FDA, USDA and 3-A.
- ▶ Turnkey conveyor that is easy to install and start up.
- ▶ Manual dismounting and cleaning.
- ▶ Low sound level.
- ▶ Fully pneumatic.
- ▶ Reusable textile bag filter.

### TECHNICAL DATA

Description	Unit	Value
Feed pressure range	MPa	0.4–0.6
Air consumption range	NI/s	5–7
Vacuum range	-kPa	61–75
Noise level range	dB(A)	72–76
Material		ASTM 316L, PPS, Q
Temperature range	°C	0–60
Weight	kg	13.9
Safety classification		IP54
Filter area	m <sup>2</sup>	0.06
Material batch volume	l	3.8
Min particle size	µm	5.0

### CAPACITY

Capacity ton/h at different conveying distances			
5 m	10 m	20 m	30 m
0.90	0.45	0.20	–

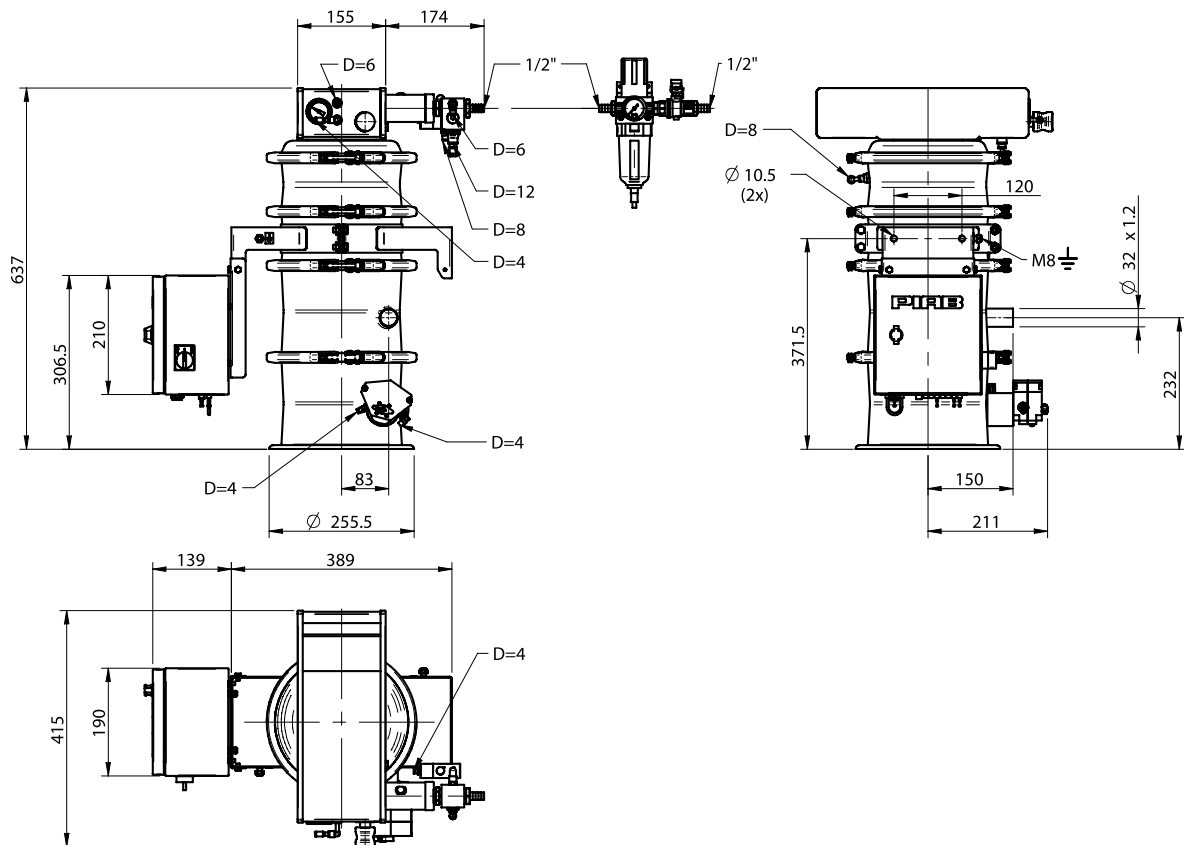

## PARTS INCLUDED

Description	Art. No.
Pump unit Maxi L100	0106812
Filter unit 2101 textile filter int, Q	0106057/2
Connection unit 21/16 D=32 tang Q	0104498/2
Bottom valve unit 21/16 SS Q	0106787/2
Control unit CU-1B bracket	0103919
Nylon tubing kit, Standard CU-C21	0106978

## C2102-100



- ▶ Designed mainly for industries handling food, chemical and pharmaceutical products.
- ▶ Solution that contributes to dust-free conveying.
- ▶ All materials in contact with the conveyed product fulfil the requirements of FDA, USDA and 3-A.
- ▶ Turnkey conveyor that is easy to install and start up.
- ▶ Manual dismounting and cleaning.
- ▶ Low sound level.
- ▶ Fully pneumatic.
- ▶ Reusable textile bag filter.

### TECHNICAL DATA

Description	Unit	Value
Feed pressure range	MPa	0.4–0.6
Air consumption range	NI/s	5–7
Vacuum range	-kPa	61–75
Noise level range	dB(A)	72–76
Material		ASTM 316L, PPS, Q
Temperature range	°C	0–60
Weight	kg	22.00
Safety classification		IP54
Filter area	m <sup>2</sup>	0.09
Material batch volume	l	3.8
Min particle size	µm	5.0

### CAPACITY

Capacity ton/h at different conveying distances			
5 m	10 m	20 m	30 m
0.90	0.45	0.20	–

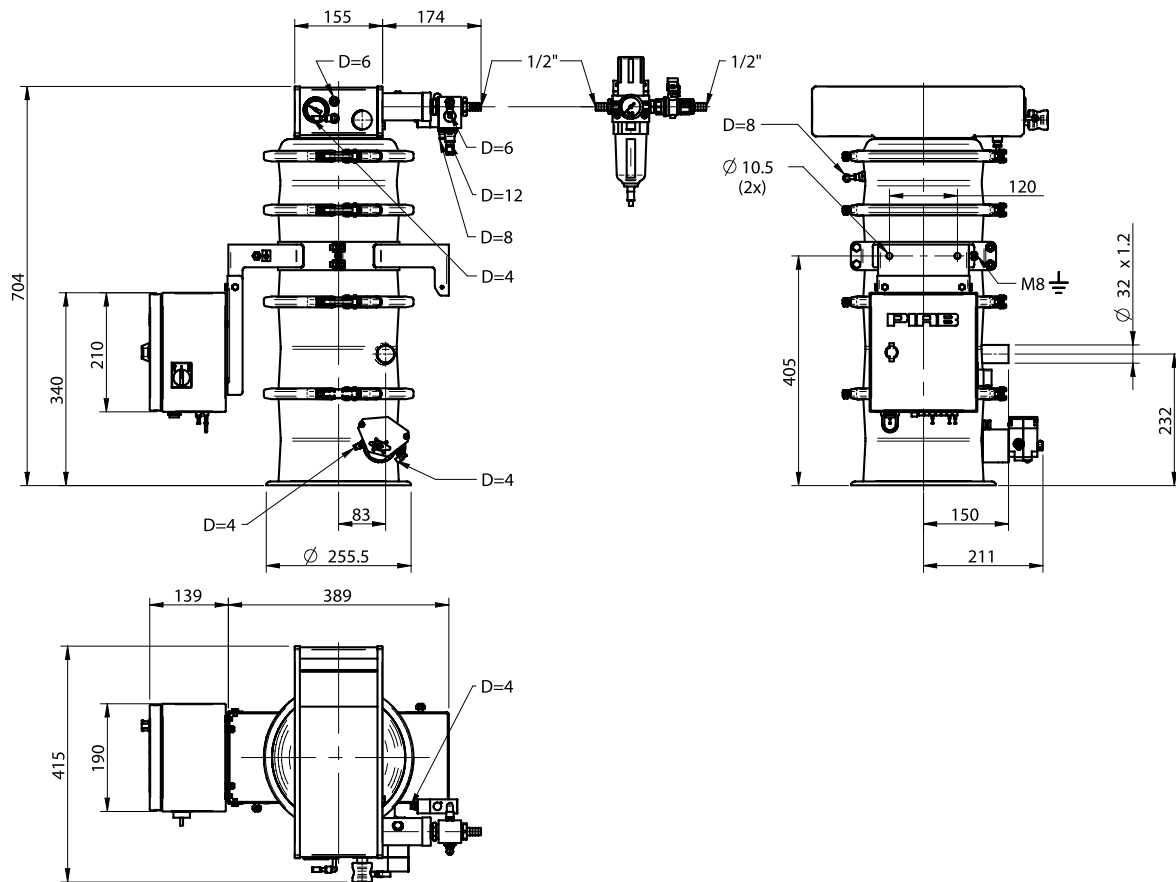

## PARTS INCLUDED

Description	Art. No.
Pump unit Maxi L100	0106812
Filter unit 2102 textile filter int, Q	0106054/2
Connection unit 21/16 D=tang Q	0104798/2
Bottom valve unit 21/16 SS, fluid, Q	0106591/2
Control unit CU-1B bracket	0103919
Nylon tubing kit, Standard CU-C21	0106978

## C2104-200



- ▶ Designed mainly for industries handling food, chemical and pharmaceutical products.
- ▶ Solution that contributes to dust-free conveying.
- ▶ All materials in contact with the conveyed product fulfil the requirements of FDA, USDA and 3-A.
- ▶ Turnkey conveyor that is easy to install and start up.
- ▶ Manual dismounting and cleaning.
- ▶ Low sound level.
- ▶ Fully pneumatic.
- ▶ Reusable textile bag filter.

### TECHNICAL DATA

Description	Unit	Value
Feed pressure range	MPa	0.4–0.6
Air consumption range	NI/s	10–14
Vacuum range	-kPa	61–75
Noise level range	dBA	72–76
Material		ASTM 316L, Q
Temperature range	°C	0–60
Weight	kg	24.0
Safety classification		IP54
Filter area	m <sup>2</sup>	0.14
Material batch volume	l	3.8
Min particle size	µm	5.0

### CAPACITY

Capacity ton/h at different conveying distances			
5 m	10 m	20 m	30 m
1.80	0.90	0.50	0.30



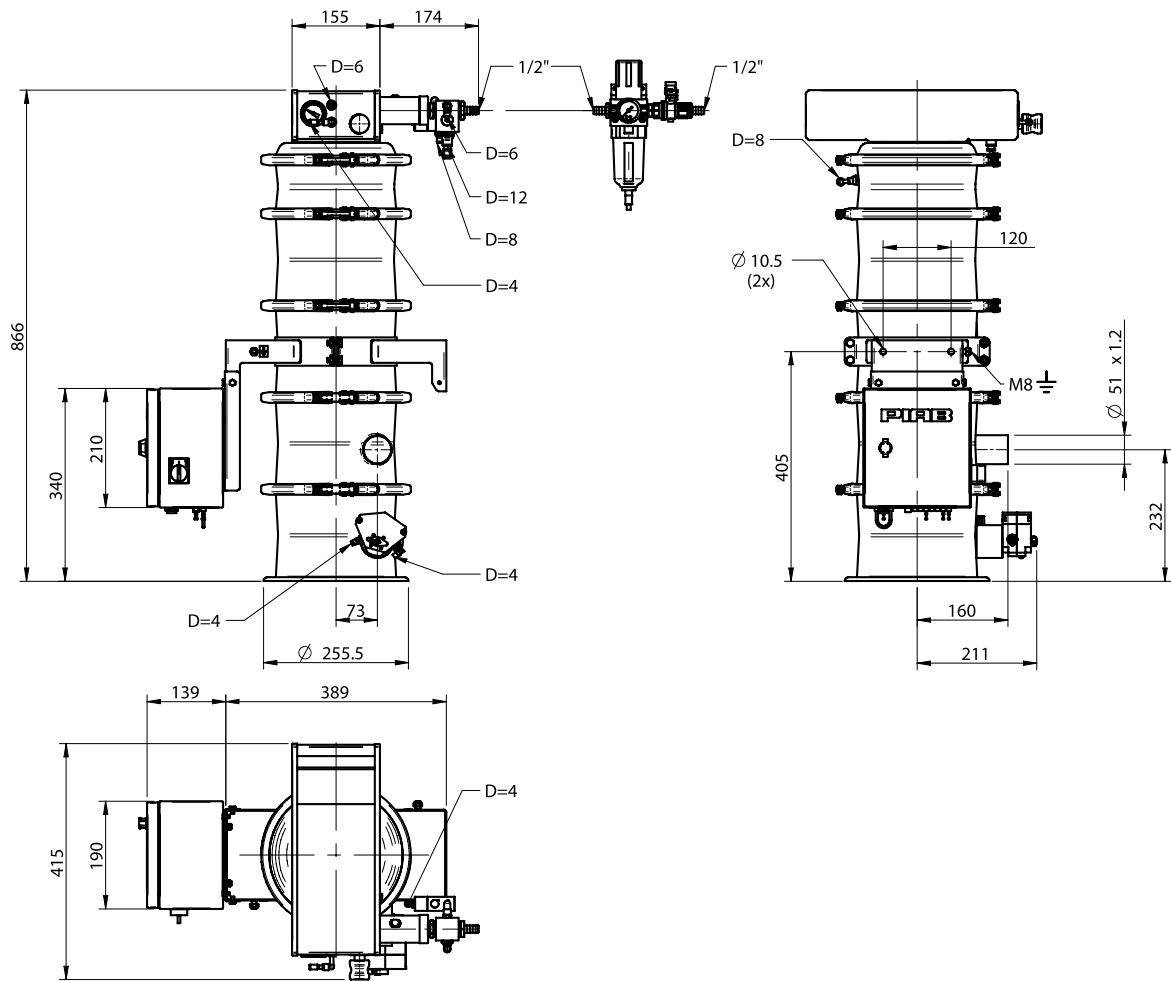

Conveyors C COMPLETE

## PARTS INCLUDED

Description	Art. No.
Pump unit Maxi L200	0103878
Filter unit 2104 textile filter int, Q	0106058/2
Connection unit 21/16 D=51 tang Q	0104514/2
Bottom valve unit 21/16 SS Q	0106787/2
Control unit CU-1B bracket	0103919
Nylon tubing kit, Standard CU-C21	0106978

## C2102S-100



- ▶ USDA and 3-A accepted conveyors that meet the stringent sanitary requirements of the food, dairy and pharmaceutical industries.
- ▶ Solution that contributes to dust-free conveying.
- ▶ Turnkey conveyor that is easy to install and start up.
- ▶ Manual dismounting and cleaning.
- ▶ Low sound level.
- ▶ Fully pneumatic.
- ▶ External filter shock assembly.
- ▶ Gore Sinbran filters with PTFE membrane.

### TECHNICAL DATA

Description	Unit	Value
Feed pressure range	MPa	0.4–0.6
Air consumption range	NI/s	5–7
Vacuum range	-kPa	61–75
Noise level range	dBA	72–76
Material		ASTM 316L, Q
Temperature range	°C	0–60
Weight	kg	29.0
Safety classification		IP54
Filter area	m <sup>2</sup>	0.11
Material batch volume	l	3.8
Min particle size	µm	0.5

### CAPACITY

Capacity ton/h at different conveying distances			
5 m	10 m	20 m	30 m
0.90	0.45	0.20	–

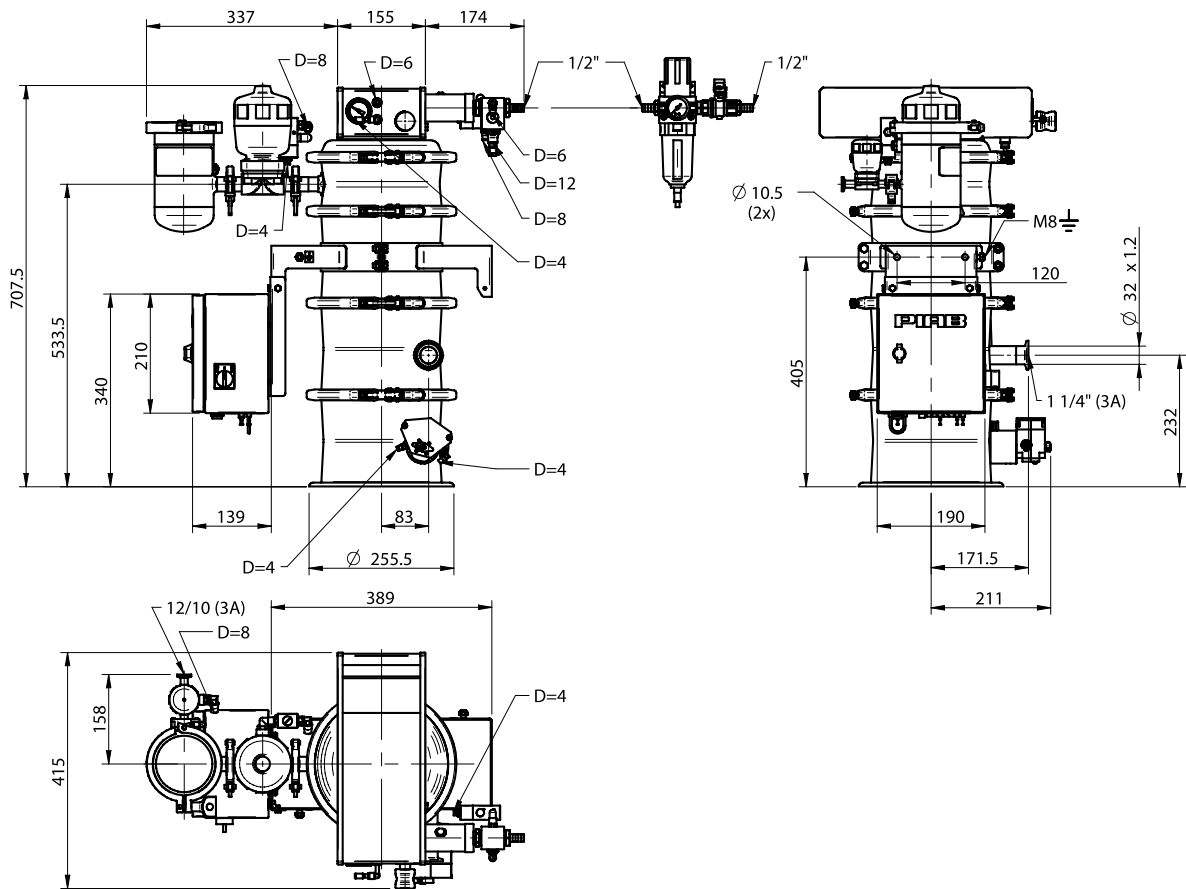

## PARTS INCLUDED

Description	Art. No.
Pump unit Maxi L100	0106812
Filter unit 2102 Gore Sinbran ext, Q	0106190/2
Connection unit 21/16 D=32 tang 3-A, Q	0106113/2
Bottom valve unit 21/16 SS Q	0106787/2
Control unit CU-1B bracket	0103919
Nylon tubing kit, Standard CU-C21	0106978

## C2104S-200



- ▶ USDA and 3-A accepted conveyors that meet the stringent sanitary requirements of the food, dairy and pharmaceutical industries.
- ▶ Solution that contributes to dust-free conveying.
- ▶ Turnkey conveyor that is easy to install and start up.
- ▶ Manual dismantling and cleaning.
- ▶ Low sound level.
- ▶ Fully pneumatic.
- ▶ External filter shock assembly.
- ▶ Gore Sinbran filters with PTFE membrane.

### TECHNICAL DATA

Description	Unit	Value
Feed pressure range	MPa	0.4–0.6
Air consumption range	NI/s	10–14
Vacuum range	-kPa	61–75
Noise level range	dBA	72–76
Material		ASTM 316L, Q
Temperature range	°C	0–60
Weight	kg	29.0
Safety classification		IP54
Filter area	m <sup>2</sup>	0.19
Material batch volume	l	3.8
Min particle size	µm	0.5

### CAPACITY

Capacity ton/h at different conveying distances			
5 m	10 m	20 m	30 m
1.80	0.90	0.50	0.30

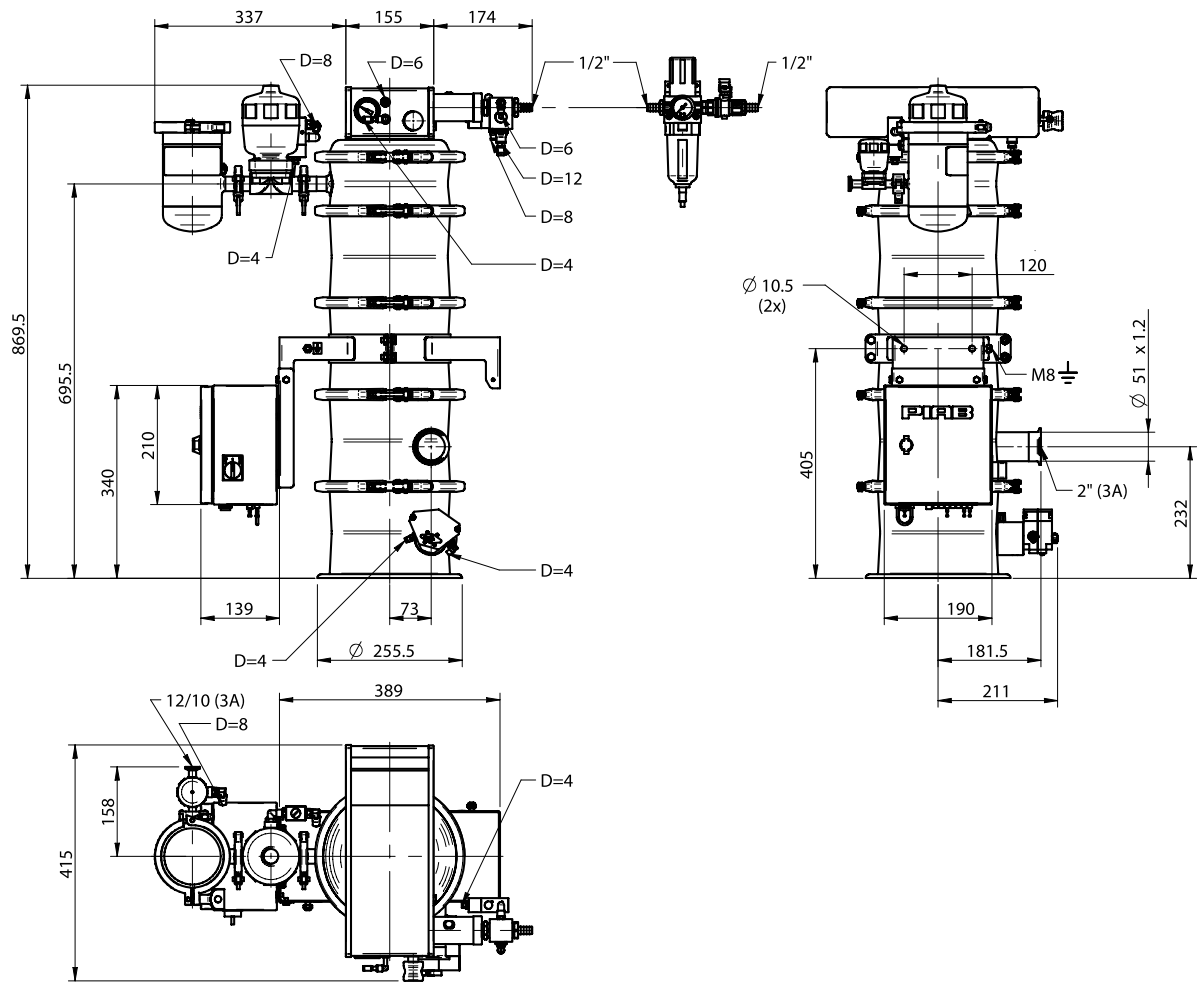

## PARTS INCLUDED

Description	Art. No.
Pump unit Maxi L200	0103878
Filter unit 2104 Gore Sinbran ext, Q	0106198/2
Connection unit 21/16 D=51 tang Q	0104514/2
Bottom valve unit 21/16 SS Q	0106787/2
Control unit CU-1B bracket	0103919
Nylon tubing kit, Standard CU-C21	0106978

## C3302-400



- ▶ Designed mainly for industries handling food, chemical and pharmaceutical products.
- ▶ Solution that contributes to dust-free conveying.
- ▶ All materials in contact with the conveyed product fulfil the requirements of FDA, USDA and 3-A.
- ▶ Turnkey conveyor that is easy to install and start up.
- ▶ Manual dismounting and cleaning.
- ▶ Low sound level.
- ▶ Fully pneumatic.
- ▶ Reusable textile bag filter.

### TECHNICAL DATA

Description	Unit	Value
Feed pressurer range	MPa	0.4–0.6
Air consumption range	NI/s	20–28
Vacuum range	-kPa	61–75
Noise level range	dBA	72–76
Material		ASTM 316L, Q
Temperature range	°C	0–60
Weight	kg	36.0
Safety classification		IP54
Filter area	m <sup>2</sup>	0.26
Material batch volume	l	14.0
Min particle size	µm	5.0

### CAPACITY

Capacity ton/h at different conveying distances			
5 m	10 m	20 m	30 m
3.60	1.80	1.00	0.60

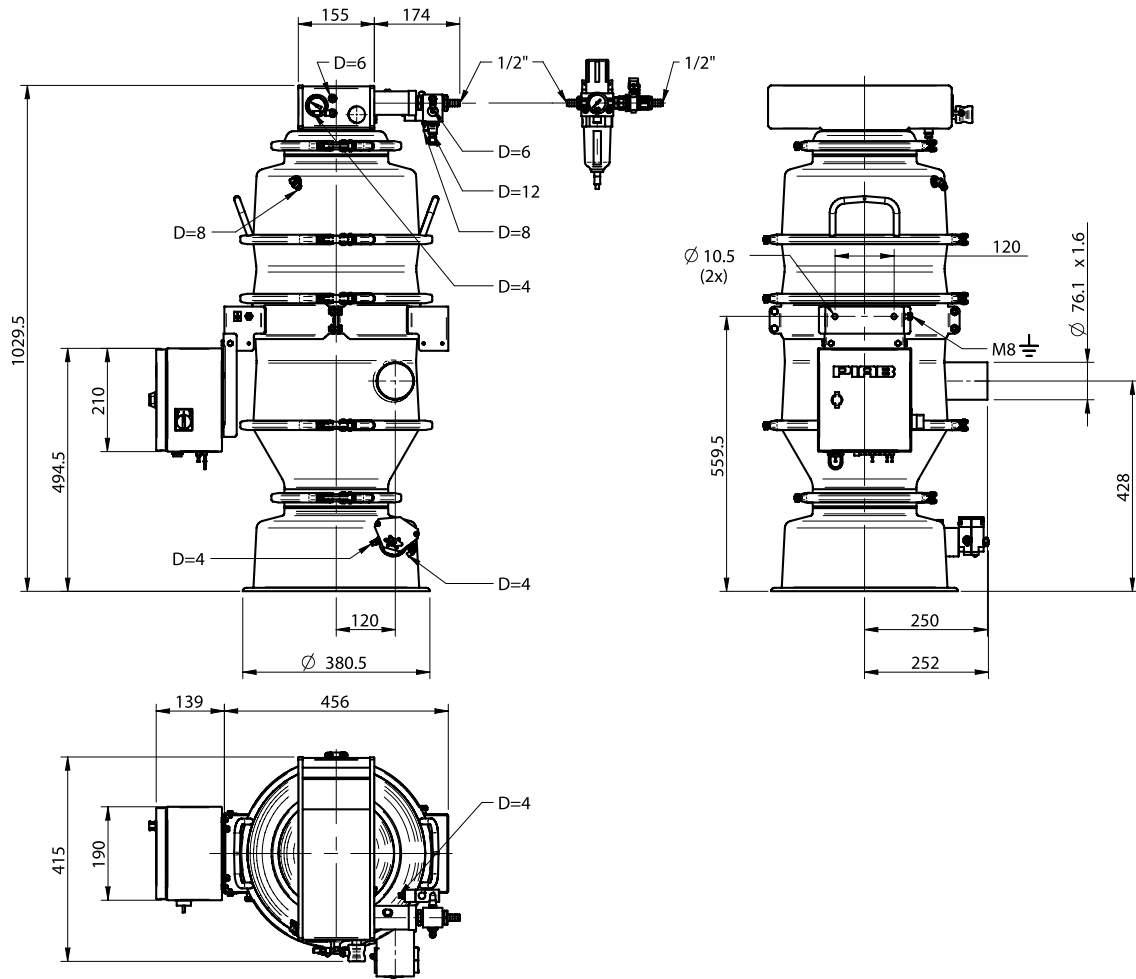

## PARTS INCLUDED

Description	Art. No.
Pump unit Maxi L400	0103879
Filter unit 3302 Pitex int Q	0103887/2
Connection unit 33/26 D=76 tang Q	0103884/2
Bottom valve unit 33/34 SS Q	0103907/2
Control unit CU-1B bracket	0103919
Tubing kit, nylon, standard CU-C33	0103929

## C3304-400



- ▶ Designed mainly for industries handling food, chemical and pharmaceutical products.
- ▶ Solution that contributes to dust-free conveying.
- ▶ All materials in contact with the conveyed product fulfil the requirements of FDA, USDA and 3-A.
- ▶ Turnkey conveyor that is easy to install and start up.
- ▶ Manual dismounting and cleaning.
- ▶ Low sound level.
- ▶ Fully pneumatic.
- ▶ Reusable textile bag filter.

### TECHNICAL DATA

Description	Unit	Value
Feed pressure range	MPa	0.4–0.6
Air consumption range	NI/s	20–28
Vacuum range	-kPa	61–75
Noise level range	dBA	72–76
Material		ASTM 316L, Q
Temperature range	°C	0–60
Weight	kg	44.0
Safety classification		IP54
Filter area	m <sup>2</sup>	0.42
Material batch volume	l	14.0
Min particle size	µm	5.0

### CAPACITY

Capacity ton/h at different conveying distances			
5 m	10 m	20 m	30 m
3.60	1.80	1.00	0.60



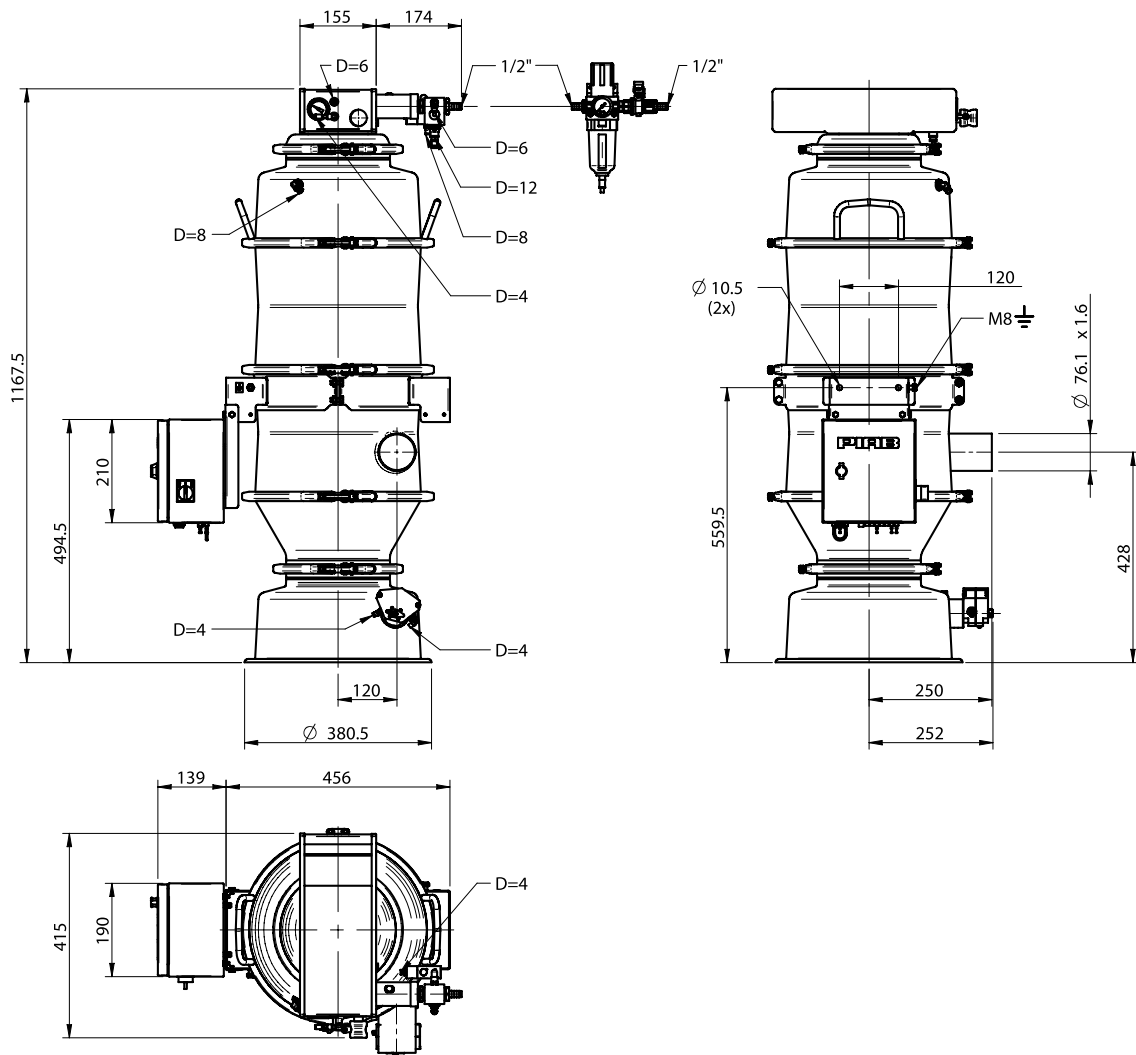

Conveyors C COMPLETE

## PARTS INCLUDED

Description	Art. No.
Pump unit Maxi L400	0103879
Filter unit 3304 textile filter int, Q	0103888/2
Connection unit 33/26 D=76 tang, Q	0103884/2
Bottom valve unit 33/34 SS, Q	0103907/2
Control unit CU-1B bracket	0103919
Nylon tubing kit Standard CU-C33	0103929

## C3304-600



- ▶ Designed mainly for industries handling food, chemical and pharmaceutical products.
- ▶ Solution that contributes to dust-free conveying.
- ▶ All materials in contact with the conveyed product fulfil the requirements of FDA, USDA and 3-A.
- ▶ Turnkey conveyor that is easy to install and start up.
- ▶ Manual dismounting and cleaning.
- ▶ Low sound level.
- ▶ Fully pneumatic.
- ▶ Reusable textile bag filter.

### TECHNICAL DATA

Description	Unit	Value
Feed pressure range	MPa	0.4–0.6
Air consumption range	NI/s	30–42
Vacuum range	-kPa	61–75
Noise level	dB(A)	72–76
Material		ASTM 316L, Q
Temperature range	°C	0–60
Weight	kg	41.0
Safety classification		IP54
Filter area	m <sup>2</sup>	0.42
Material batch volume	l	14.0
Min particle size	µm	5.0

### CAPACITY

Capacity ton/h at different conveying distances			
5 m	10 m	20 m	30 m
5.40	2.60	1.40	0.90

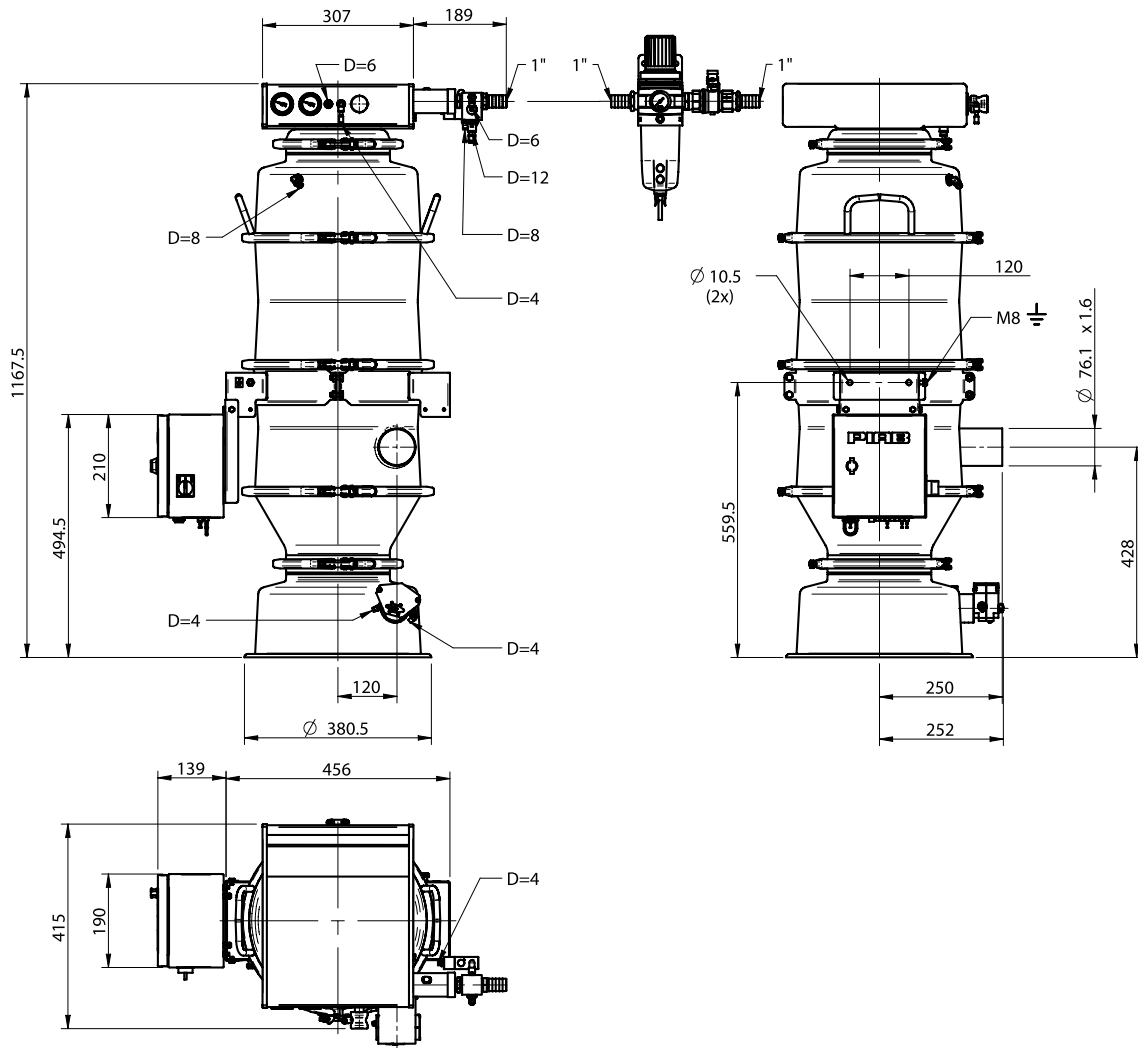

## PARTS INCLUDED

Description	Art. No.
Pump unit Maxi L600	0103880
Filter unit 3304 textile filter int, Q	0103888/2
Connection unit 33/26 D=76 tang, Q	0103884/2
Bottom valve unit 33/34 SS, Q	0103907/2
Control unit CU-1B bracket	0103919
Nylon tubing kit Standard CU-C33	0103929

## C3306-600



- ▶ Designed mainly for industries handling food, chemical and pharmaceutical products.
- ▶ Solution that contributes to dust-free conveying.
- ▶ All materials in contact with the conveyed product fulfil the requirements of FDA, USDA and 3-A.
- ▶ Turnkey conveyor that is easy to install and start up.
- ▶ Manual dismounting and cleaning.
- ▶ Low sound level.
- ▶ Fully pneumatic.
- ▶ Reusable textile bag filter.

### TECHNICAL DATA

Description	Unit	Value
Feed pressure range	MPa	0.4–0.6
Air consumption	NI/s	30–42
Vacuum range	-kPa	61–75
Noise level range	dB(A)	72–76
Material		ASTM 316L, Q
Temperature range	°C	0–60
Weight	kg	45.0
Safety classification		IP54
Filter area	m <sup>2</sup>	0,70
Material batch volume	l	14.0
Min particle size	µm	5.0

### CAPACITY

Capacity ton/h at different conveying distances			
5 m	10 m	20 m	30 m
5.40	2.60	1.40	0.90

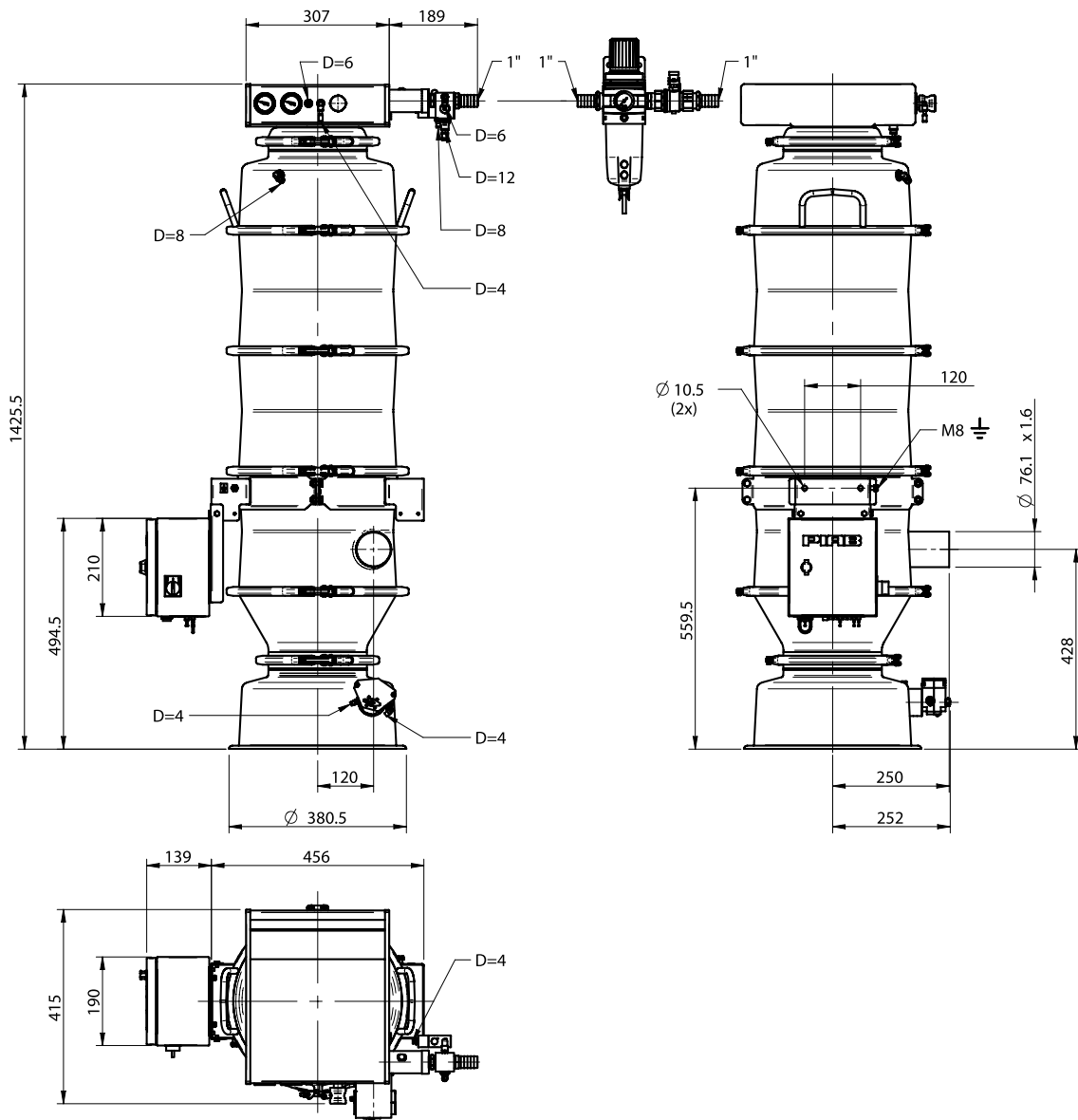

Conveyors C COMPLETE

## PARTS INCLUDED

Description	Art. No.
Pump unit Maxi L600	0103880
Filter unit 3306 textile filter int, Q	0103889/2
Connection unit 33/26 D=76 tang, Q	0103884/2
Bottom valve unit 33/34 SS, Q	0103907/2
Control unit CU-1B bracket	0103919
Nylon tubing kit Standard CU-C33	0103929

## C3306-800



- ▶ Designed mainly for industries handling food, chemical and pharmaceutical products.
- ▶ Solution that contributes to dust-free conveying.
- ▶ All materials in contact with the conveyed product fulfil the requirements of FDA, USDA and 3-A.
- ▶ Turnkey conveyor that is easy to install and start up.
- ▶ Manual dismounting and cleaning.
- ▶ Low sound level.
- ▶ Fully pneumatic.
- ▶ Reusable textile bag filter.

### TECHNICAL DATA

Description	Unit	Value
Feed pressure range	MPa	0.4–0.6
Air consumption range	NI/s	40–56
Vacuum range	-kPa	61–75
Noise level range	dBA	72–76
Material		ASTM 316L, Q
Temperature range	°C	0–60
Weight	kg	45.0
Safety classification		IP54
Filter area	m <sup>2</sup>	0.70
Material batch volume	l	14.0
Min particle size	µm	5.0

### CAPACITY

Capacity ton/h at different conveying distances			
5 m	10 m	20 m	30 m
7.20	3.60	1.80	1.20

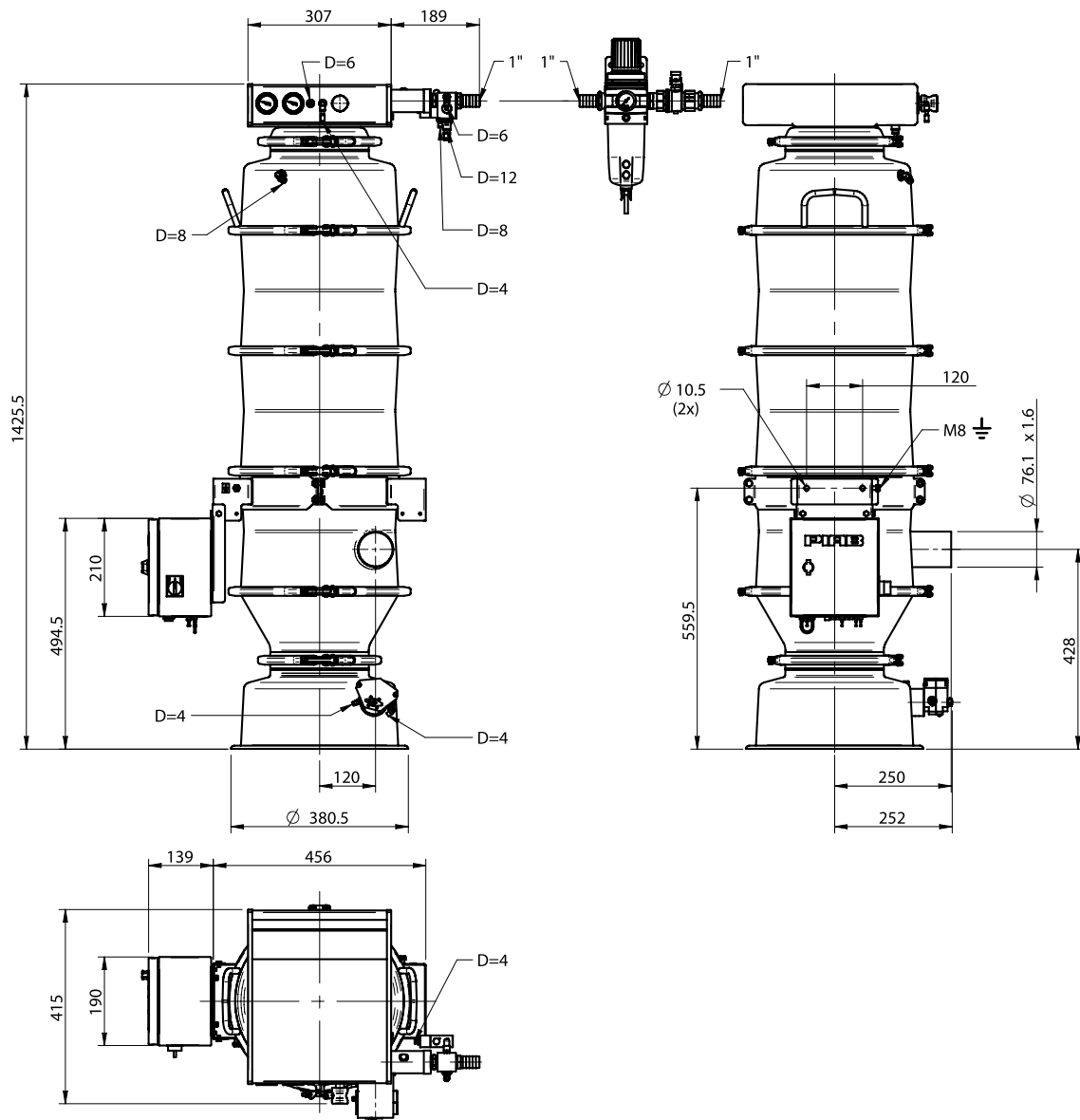

## PARTS INCLUDED

Description	Art. No.
Pump unit Maxi L600	0103880
Filter unit 3306 textile filter int, Q	0103889/2
Connection unit 33/26 D=76 tang, Q	0103884/2
Bottom valve unit 33/34 SS, Q	0103907/2
Control unit CU-1B bracket	0103919
Nylon tubing kit Standard CU-C33	0103929

## C3302S-400



- ▶ USDA and 3-A accepted conveyors that meet the stringent sanitary requirements of the food, dairy and pharmaceutical industries.
- ▶ Solution that contributes to dust-free conveying.
- ▶ Turnkey conveyor that is easy to install and start up.
- ▶ Manual dismounting and cleaning.
- ▶ Low sound level.
- ▶ Fully pneumatic.
- ▶ External filter shock assembly.
- ▶ Gore Sinbran filters with PTFE membrane.

### TECHNICAL DATA

Description	Unit	Value
Feed pressure range	MPa	0.4–0.6
Air consumption range	NI/s	20–28
Vacuum range	-kPa	61–75
Noise level range	dBA	72–76
Material		ASTM 316L, Q
Temperature range	°C	0–60
Weight	kg	44.0
Safety classification		IP54
Filter area	m <sup>2</sup>	0.34
Material batch volume	l	14.0
Min particle size	µm	0.5

### CAPACITY

Capacity ton/h at different conveying distances			
5 m	10 m	20 m	30 m
3.60	1.80	1.00	0.60



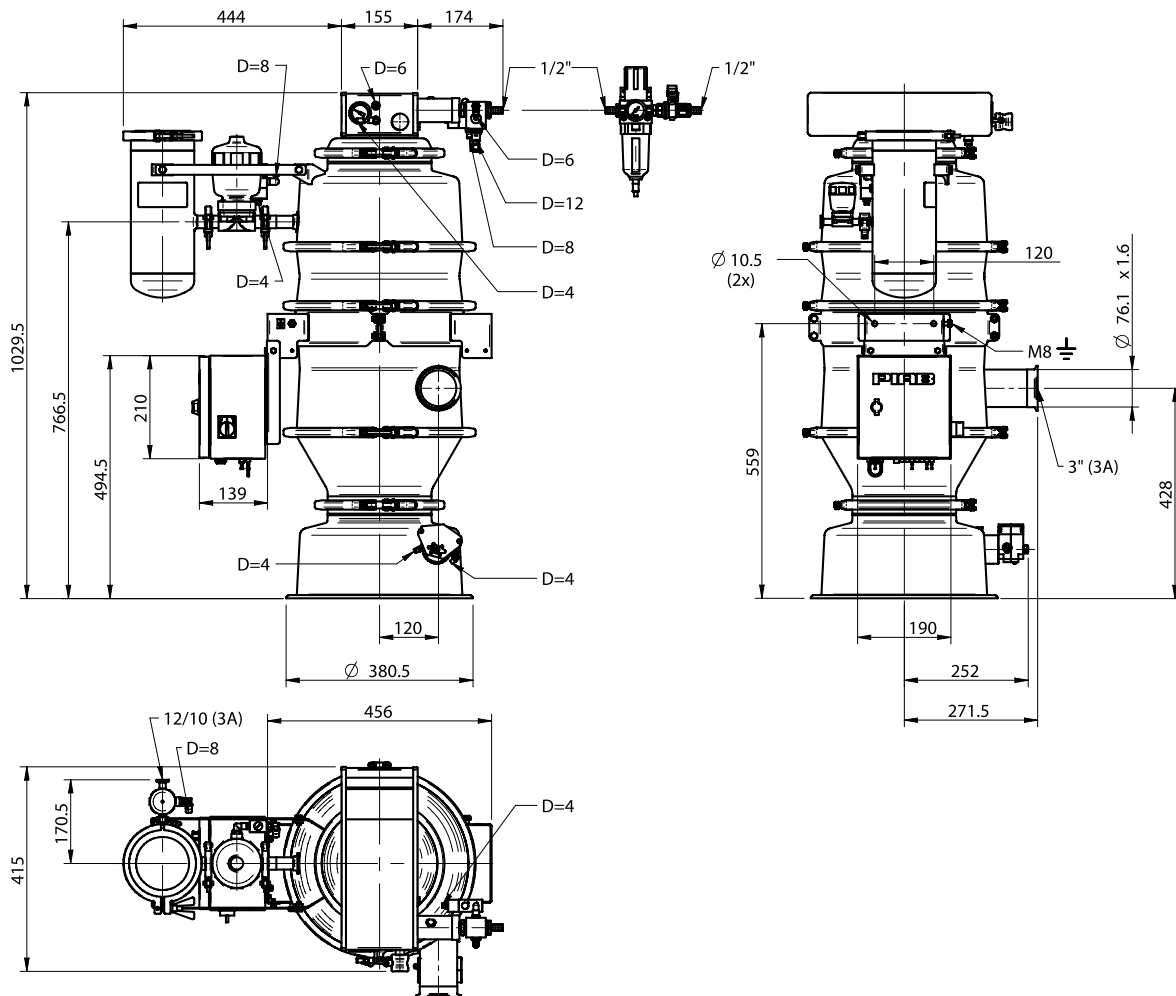

## PARTS INCLUDED

Description	Art. No.
Pump unit Maxi L400	0103879
Filter unit 3302 Gore Sinbran ext, Q	0103896/2
Connection unit 33/26 D=75 tang 3-A, Q	0103885/2
Bottom valve unit 33/34 SS, Q	0103907/2
Control unit CU-1B bracket	0103919
Nylon tubing kit Standard CU-C33	0103929

## C3304S-400

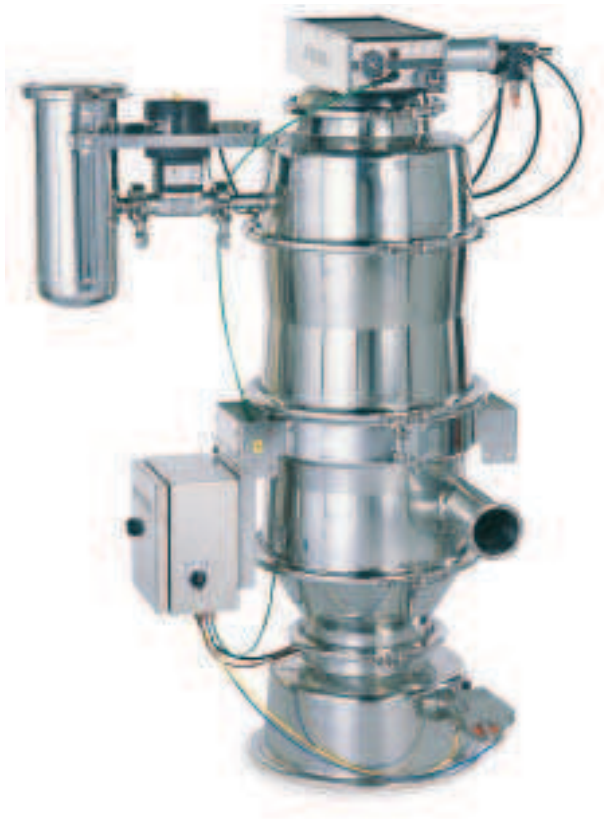

- ▶ USDA and 3-A accepted conveyors that meet the stringent sanitary requirements of the food, dairy and pharmaceutical industries.
- ▶ Solution that contributes to dust-free conveying.
- ▶ Turnkey conveyor that is easy to install and start up.
- ▶ Manual dismounting and cleaning.
- ▶ Low sound level.
- ▶ Fully pneumatic.
- ▶ External filter shock assembly.
- ▶ Gore Sinbran filters with PTFE membrane.

### TECHNICAL DATA

Description	Unit	Value
Feed pressure range	MPa	0.4–0.6
Air consumption range	NI/s	20–28
Vacuum range	-kPa	61–75
Noise level range	dBA	72–76
Material		ASTM 316L, Q
Temperature range	°C	0–60
Weight	kg	46.0
Safety classification		IP54
Filter area	m <sup>2</sup>	0.57
Material batch volume	l	14.0
Min particle size	µm	0.5

### CAPACITY

Capacity ton/h at different conveying distances			
5 m	10 m	20 m	30 m
3.60	1.80	1.00	0.60

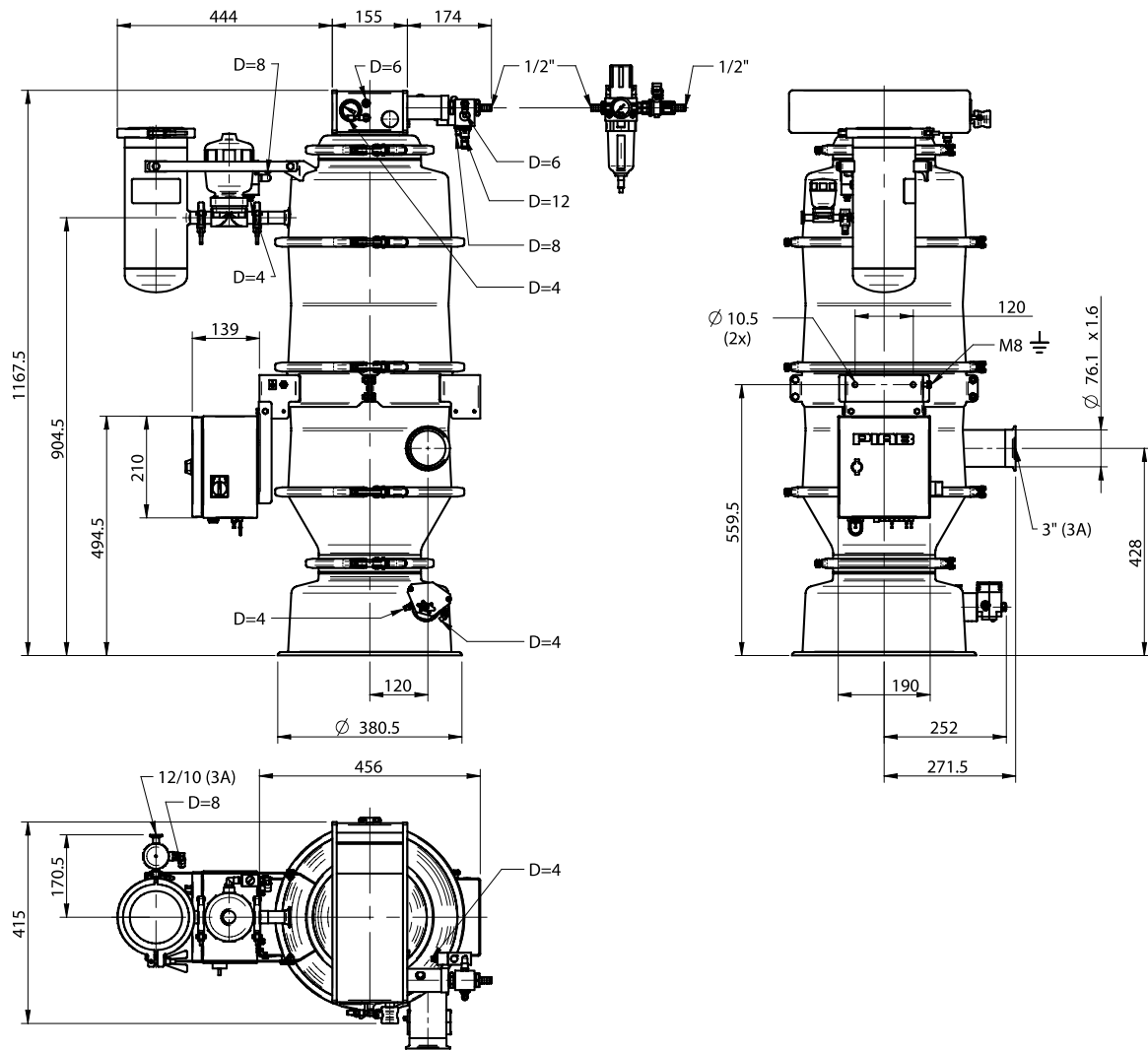

## PARTS INCLUDED

Description	Art. No.
Pump unit Maxi L400	0103879
Filter unit 3304 Gore Sinbran ext, Q	0103897/2
Connection unit 33/26 D=75 tang 3-A, Q	0103885/2
Bottom valve unit 33/34 SS, Q	0103907/2
Control unit CU-1B bracket	0103919
Nylon tubing kit Standard CU-C33	0103929

## C3304S-600



- ▶ USDA and 3-A accepted conveyors that meet the stringent sanitary requirements of the food, dairy and pharmaceutical industries.
- ▶ Solution that contributes to dust-free conveying.
- ▶ Turnkey conveyor that is easy to install and start up.
- ▶ Manual dismounting and cleaning.
- ▶ Low sound level.
- ▶ Fully pneumatic.
- ▶ External filter shock assembly.
- ▶ Gore Sinbran filters with PTFE membrane.

### TECHNICAL DATA

Description	Unit	Value
Feed pressure range	MPa	0.4–0.6
Air consumption range	NI/s	30–42
Vacuum range	-kPa	61–75
Noise level range	dBA	72–76
Material		ASTM 316L, Q
Temperature range	°C	0–60
Weight	kg	49.0
Safety classification		IP54
Filter area	m <sup>2</sup>	0.57
Material batch volume	l	14.0
Min particle size	µm	0.5

### CAPACITY

Capacity ton/h at different conveying distances			
5 m	10 m	20 m	30 m
5.40	2.60	1.40	0.90

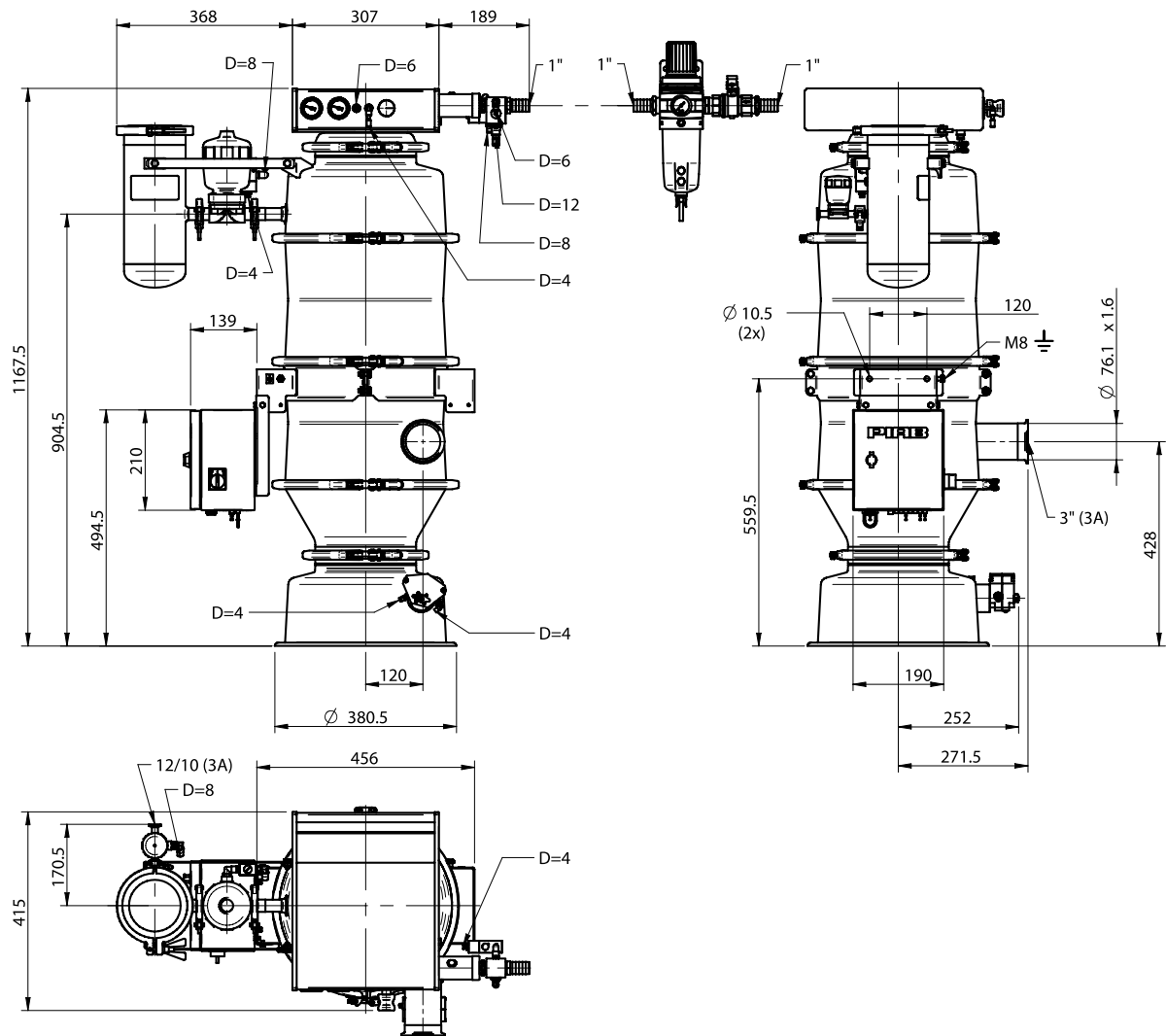

## PARTS INCLUDED

Description	Art. No.
Pump unit Maxi L600	0103880
Filter unit 3304 Gore Sinbran ext, Q	0103897/2
Connection unit 33/26 D=75 tang 3-A, Q	0103885/2
Bottom valve unit 33/34 SS, Q	0103907/2
Control unit CU-1B bracket	0103919
Nylon tubing kit Standard CU-C33	0103929

## C3306S-600



- ▶ USDA and 3-A accepted conveyors that meet the stringent sanitary requirements of the food, dairy and pharmaceutical industries.
- ▶ Solution that contributes to dust-free conveying.
- ▶ Turnkey conveyor that is easy to install and start up.
- ▶ Manual dismantling and cleaning.
- ▶ Low sound level.
- ▶ Fully pneumatic.
- ▶ External filter shock assembly.
- ▶ Gore Sinbran filters with PTFE membrane.

### TECHNICAL DATA

Description	Unit	Value
Feed pressure range	MPa	0.4–0.6
Air consumption range	NI/s	30–42
Vacuum range	-kPa	61–75
Noise level	dBA	72–76
Material		ASTM 316L, Q
Temperature range	°C	0–60
Weight	kg	53.0
Safety classification		IP54
Filter area	m <sup>2</sup>	1.02
Material batch volume	l	14.0
Min particle size	µm	0.5

### CAPACITY

Capacity ton/h at different conveying distances			
5 m	10 m	20 m	30 m
5.40	2.60	1.40	0.90

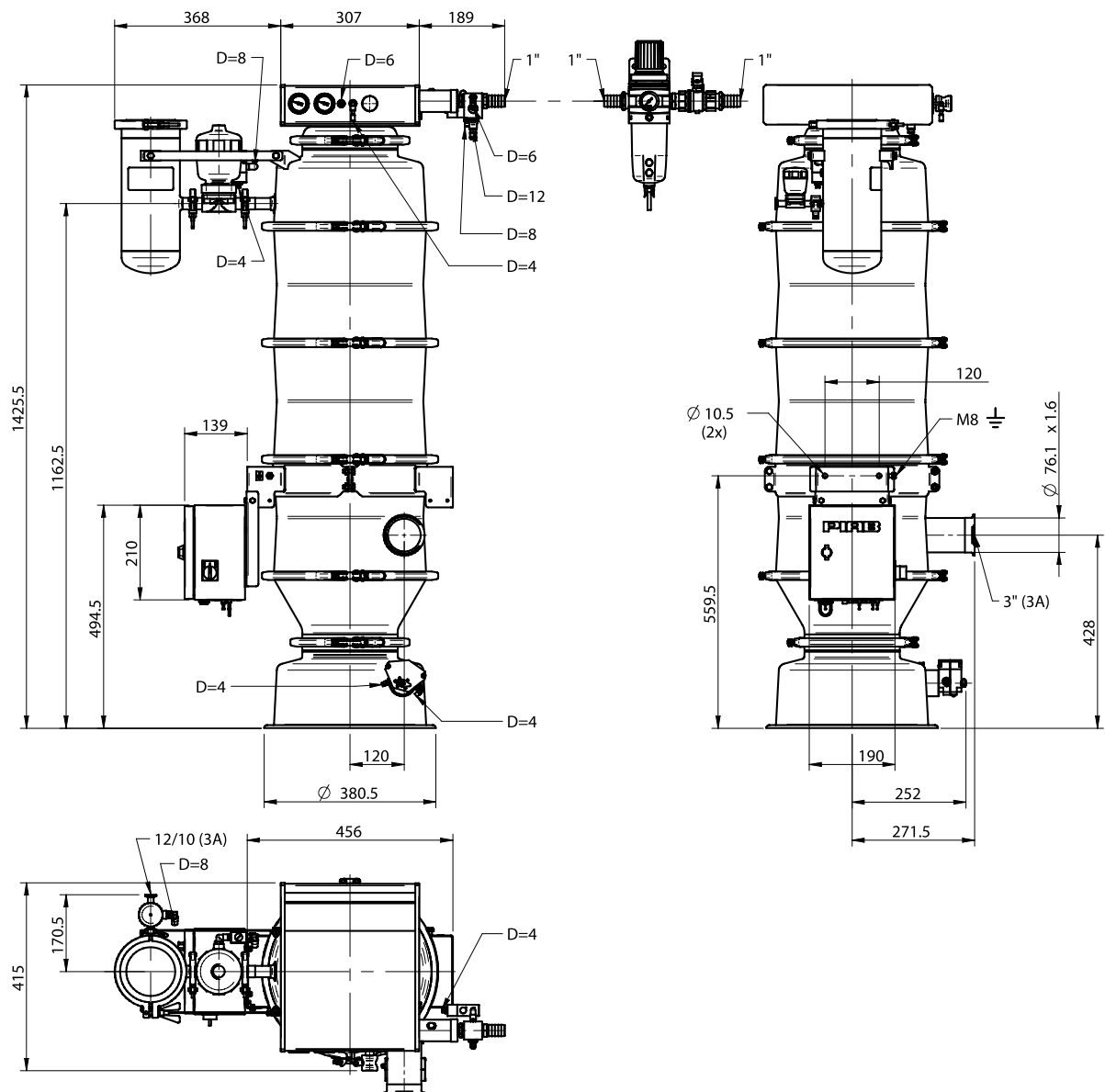

Conveyors C  
COMPLETE

## PARTS INCLUDED

Description	Art. No.
Pump unit Maxi L600	0103880
Filter unit 3306 Gore Sinbran ext, Q	0103898/2
Connection unit 33/26 D=75 tang 3-A, Q	0103885/2
Bottom valve unit 33/34 SS, Q	0103907/2
Control unit CU-1B bracket	0103919
Nylon tubing kit Standard CU-C33	0103929

## C3306S-800



- ▶ USDA and 3-A accepted conveyors that meet the stringent sanitary requirements of the food, dairy and pharmaceutical industries.
- ▶ Solution that contributes to dust-free conveying.
- ▶ Turnkey conveyor that is easy to install and start up.
- ▶ Manual dismounting and cleaning.
- ▶ Low sound level.
- ▶ Fully pneumatic.
- ▶ External filter shock assembly.
- ▶ Gore Sinbran filters with PTFE membrane.

### TECHNICAL DATA

Description	Unit	Value
Feed pressure range	MPa	0.4–0.6
Air consumption range	NI/s	40–56
Vacuum range	-kPa	61–75
Noise level range	dBA	72–76
Material		ASTM 316L, Q
Temperature range	°C	0–60
Weight	kg	53.0
Safety classification		IP54
Filter area	m <sup>2</sup>	1.02
Material batch volume	l	14.0
Min particle size	µm	0.5

### CAPACITY

Capacity ton/h at different conveying distances			
5 m	10 m	20 m	30 m
7.20	3.60	1.80	1.20



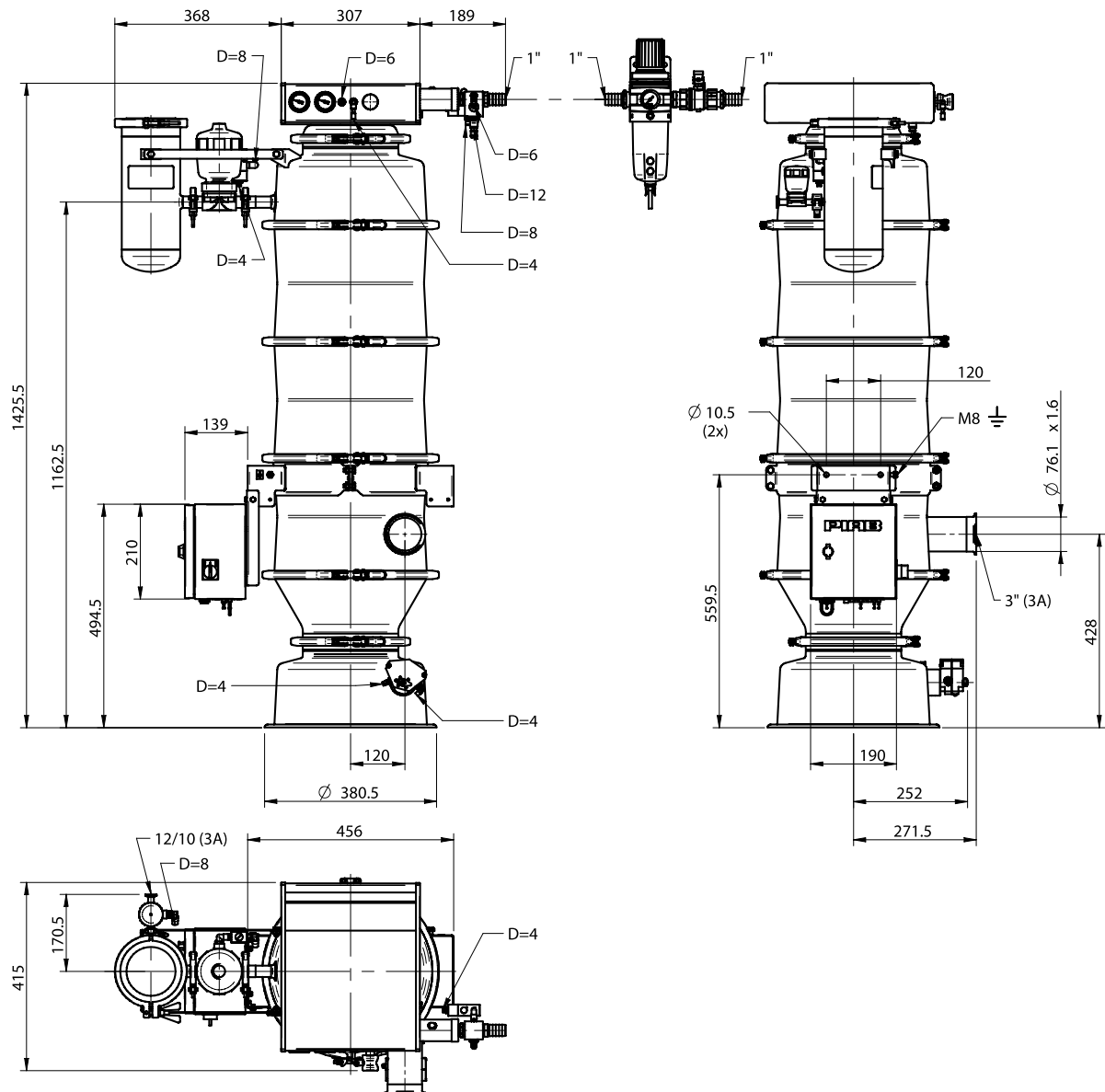

Conveyors C COMPLETE

## PARTS INCLUDED

Description	Art. No.
Pump unit Maxi L800	0103881
Filter unit 3306 Gore Sinbran ext, Q	0103898/2
Connection unit 33/26 D=75 tang 3-A, Q	0103885/2
Bottom valve unit 33/34 SS, Q	0103907/2
Control unit CU-1B bracket	0103919
Nylon tubing kit Standard CU-C33	0103929

## C5602-800



- ▶ Designed mainly for industries handling food, chemical and pharmaceutical products.
- ▶ Solution that contributes to dust-free conveying.
- ▶ All materials in contact with the conveyed product fulfil the requirements of FDA, USDA and 3-A.
- ▶ Turnkey conveyor that is easy to install and start up.
- ▶ Manual dismounting and cleaning.
- ▶ Low sound level.
- ▶ Fully pneumatic.
- ▶ Reusable textile bag filter.

### TECHNICAL DATA

Description	Unit	Value
Feed pressure range	MPa	0.04–0.6
Air consumption range	NI/s	40–56
Vacuum range	-kPa	61–75
Noise level range	dBA	72–76
Material		ASTM 316L, Q
Temperature range	°C	0–60
Weight	kg	54.0
Safety classification		IP54
Filter area	m <sup>2</sup>	0.60
Material batch volume	l	72.3
Min particle size	µm	5.0

### CAPACITY

Capacity ton/h at different conveying distances			
5 m	10 m	20 m	30 m
7.2	3.6	1.8	1.2

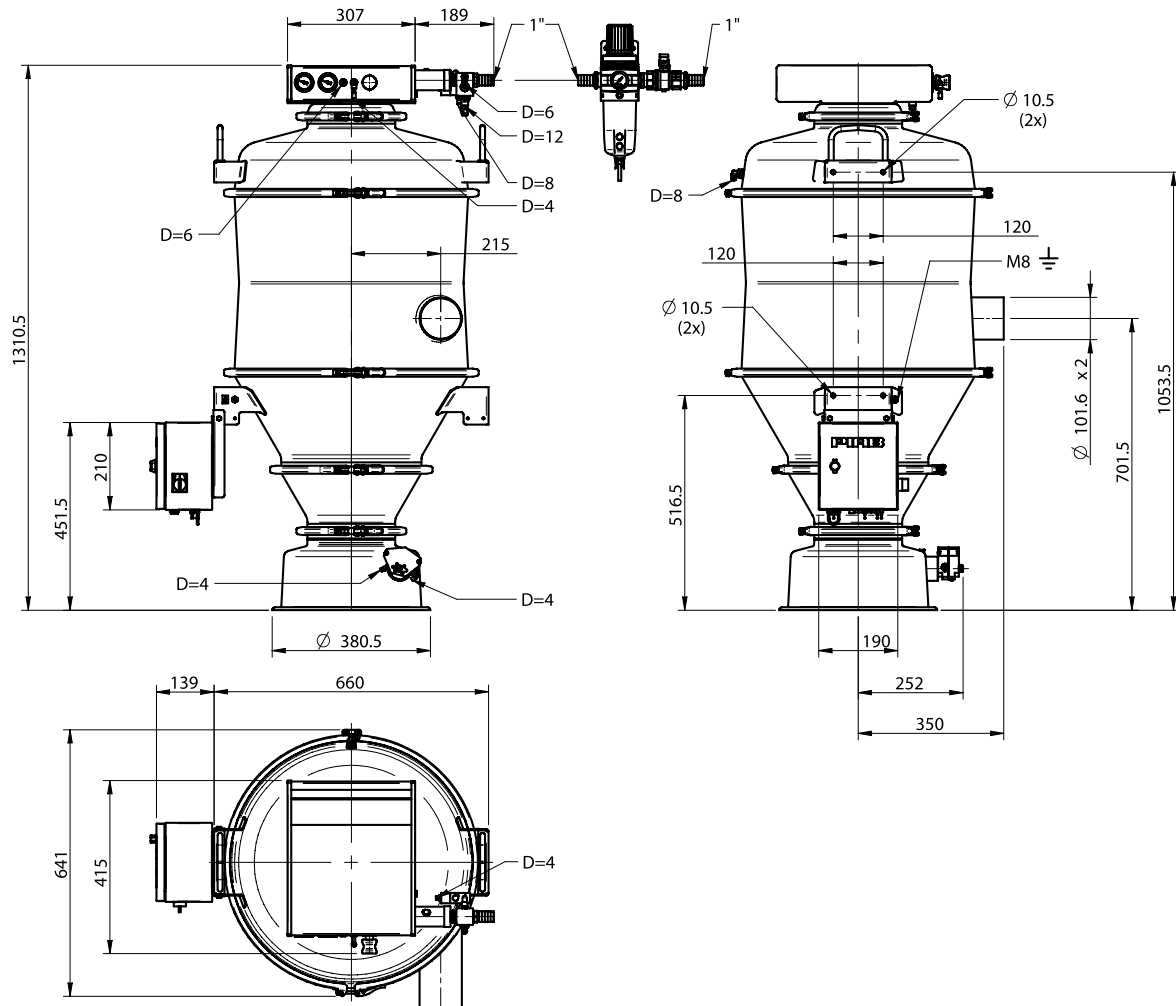

Conveyors C COMPLETE

## PARTS INCLUDED

Description	Art. No.
Pump unit Maxi L800	0103881
Filter unit 5602 textile filter int tang, Q	0106820/2
Bottom valve unit 56/57 SS Q	0106816/2
Control unit CU-1B bracket	0103919
Nylon tubing kit, Standard CU-C56	0106981

## C5604-800



- ▶ Designed mainly for industries handling food, chemical and pharmaceutical products.
- ▶ Solution that contributes to dust-free conveying.
- ▶ All materials in contact with the conveyed product fulfil the requirements of FDA, USDA and 3-A.
- ▶ Turnkey conveyor that is easy to install and start up.
- ▶ Manual dismounting and cleaning.
- ▶ Low sound level.
- ▶ Fully pneumatic.
- ▶ Reusable textile bag filter.

### TECHNICAL DATA

Description	Unit	Value
Feed pressure range	MPa	0.4–0.6
Air consumption range	NI/s	40–56
Vacuum range	-kPa	61–75
Noise level range	dBA	72–76
Material		ASTM 316L, Q
Temperature range	°C	0–60
Weight	kg	67.0
Safety classification		IP54
Filter area	m <sup>2</sup>	0.98
Material batch volume	l	72.3
Min particle size	µm	5.0

### CAPACITY

Capacity ton/h at different conveying distances			
5 m	10 m	20 m	30 m
7.2	3.6	1.8	1.2

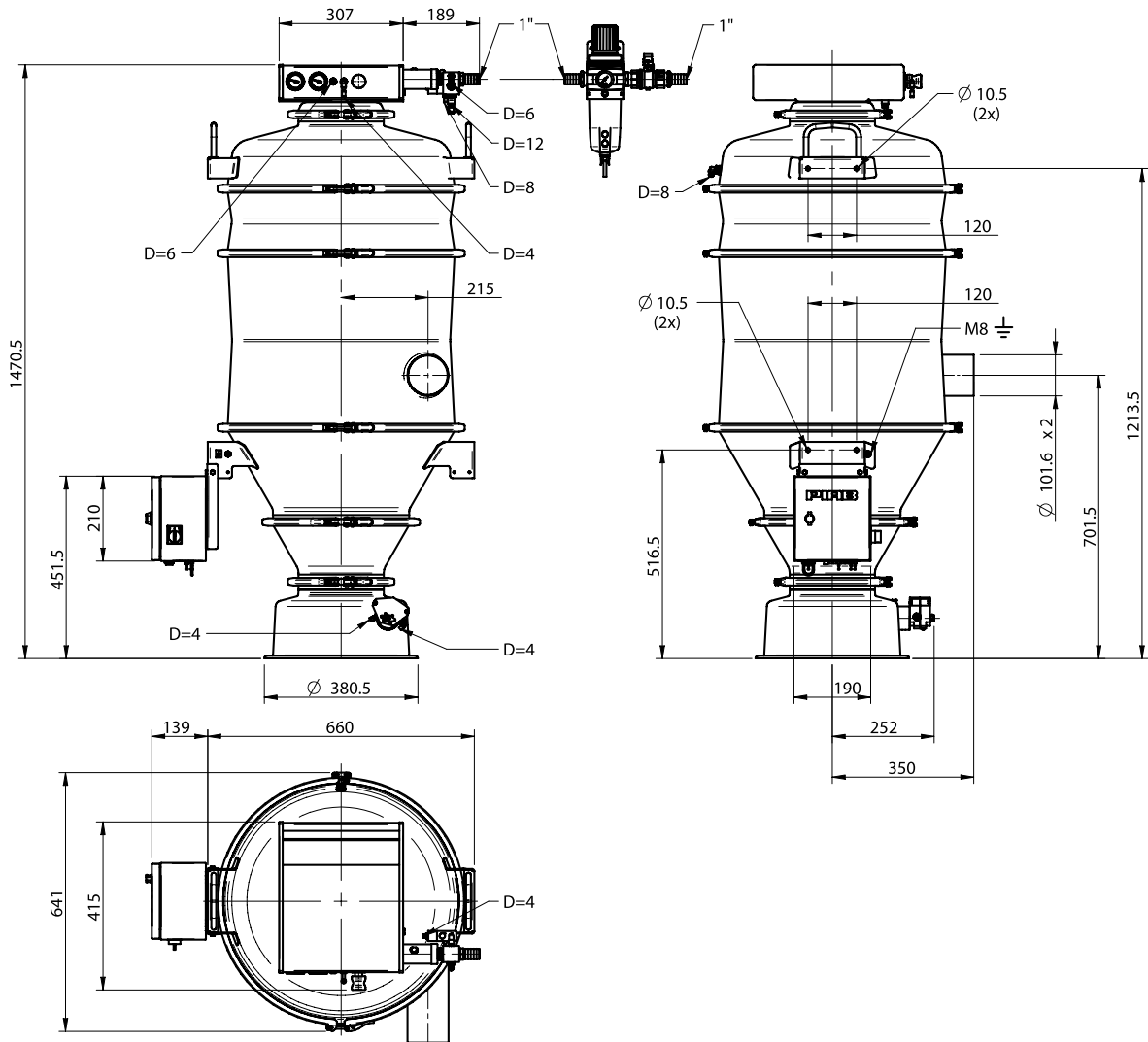

Conveyors C COMPLETE

## PARTS INCLUDED

Description	Art. No.
Pump unit Maxi L800	0103881
Filter unit 5604 textile filter int Q	0106822/2
Connection unit 56/43 D=102 tang, Q	0106239/2
Bottom valve unit 56/57 SS Q	0106816/2
Control unit CU-1B bracket	0103919
Nylon tubing kit, Standard CU-C56	0106981

## C5604-1200



- ▶ Designed mainly for industries handling food, chemical and pharmaceutical products.
- ▶ Solution that contributes to dust-free conveying.
- ▶ All materials in contact with the conveyed product fulfil the requirements of FDA, USDA and 3-A.
- ▶ Turnkey conveyor that is easy to install and start up.
- ▶ Manual dismounting and cleaning.
- ▶ Low sound level.
- ▶ Fully pneumatic.
- ▶ Reusable textile bag filter.

### TECHNICAL DATA

Description	Unit	Value
Feed pressure range	MPa	0.4–0.6
Air consumption range	NI/s	60–84
Vacuum range	-kPa	61–75
Noise level range	dBA	72–76
Material		ASTM 316L, Q
Temperature range	°C	0–60
Weight	kg	69.0
Safety classification		IP54
Filter area	m <sup>2</sup>	0.98
Material batch volume	l	72.3
Min particle size	µm	5.0

### CAPACITY

Capacity ton/h at different conveying distances			
5 m	10 m	20 m	30 m
10.80	5.40	2.70	1.80

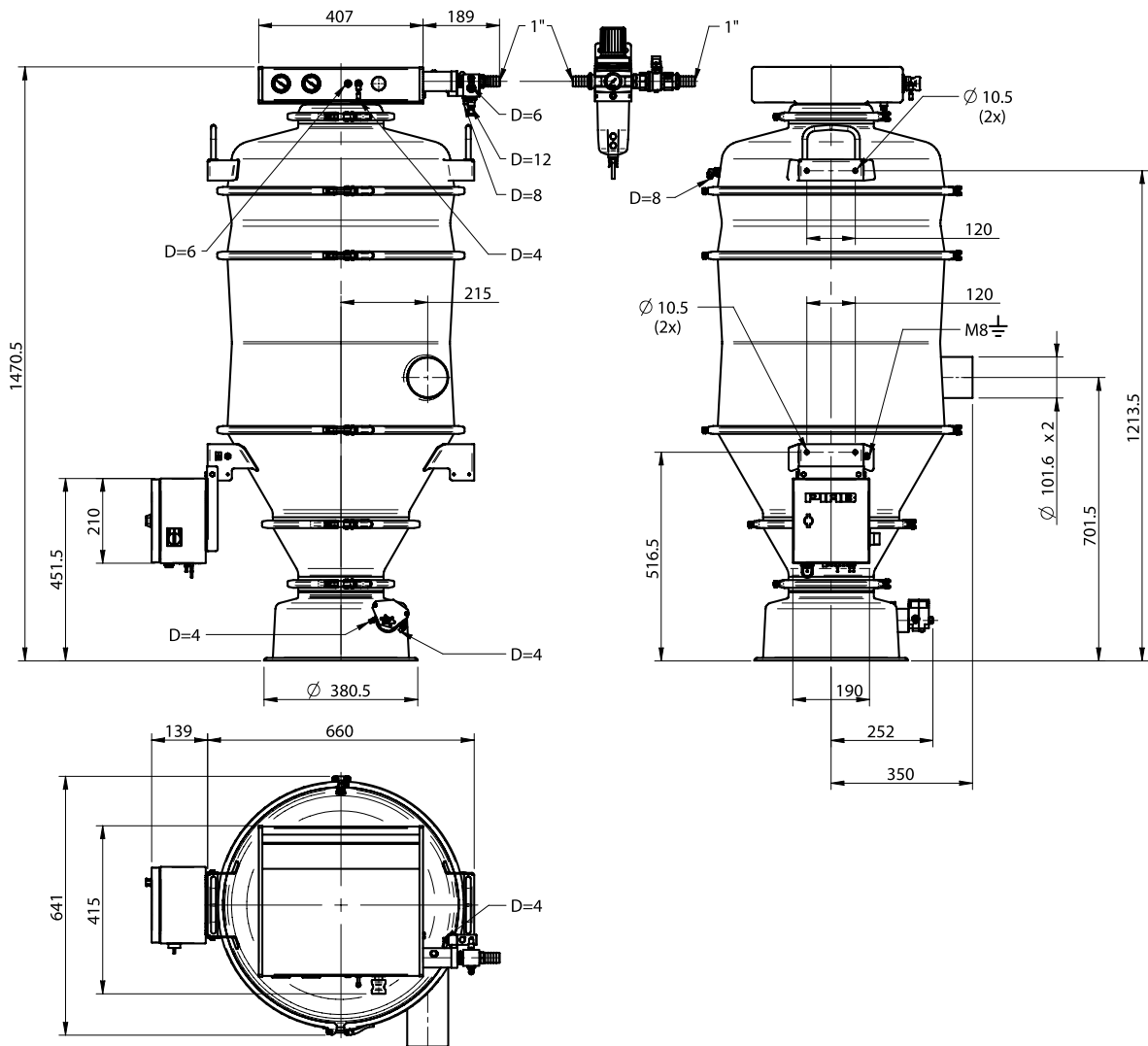

Conveyors C COMPLETE

## PARTS INCLUDED

Description	Art. No.
Pump unit Maxi L1200	0103882
Filter unit 5604 textile filter int Q	0106822/2
Connection unit 56/43 D=102 tang, Q	0106239/2
Bottom valve unit 56/57 SS Q	0106816/2
Control unit CU-1B bracket	0103919
Nylon tubing kit, Standard CU-C56	0106981

## C5606-1200



- ▶ Designed mainly for industries handling food, chemical and pharmaceutical products.
- ▶ Solution that contributes to dust-free conveying.
- ▶ All materials in contact with the conveyed product fulfil the requirements of FDA, USDA and 3-A.
- ▶ Turnkey conveyor that is easy to install and start up.
- ▶ Manual dismounting and cleaning.
- ▶ Low sound level.
- ▶ Fully pneumatic.
- ▶ Reusable textile bag filter.

### TECHNICAL DATA

Description	Unit	Value
Feed pressure range	MPa	0.4–0.6
Air consumption range	NI/s	60–84
Vacuum range	-kPa	61–75
Noise level range	dBA	72–76
Material		ASTM 316L, Q
Temperature range	°C	0–60
Weight	kg	77.0
Safety classification		IP54
Filter area	m <sup>2</sup>	1.64
Material batch volume	l	72.3
Min particle size	µm	5.0

### CAPACITY

Capacity ton/h at different conveying distances			
5 m	10 m	20 m	30 m
10.80	5.40	2.70	1.80



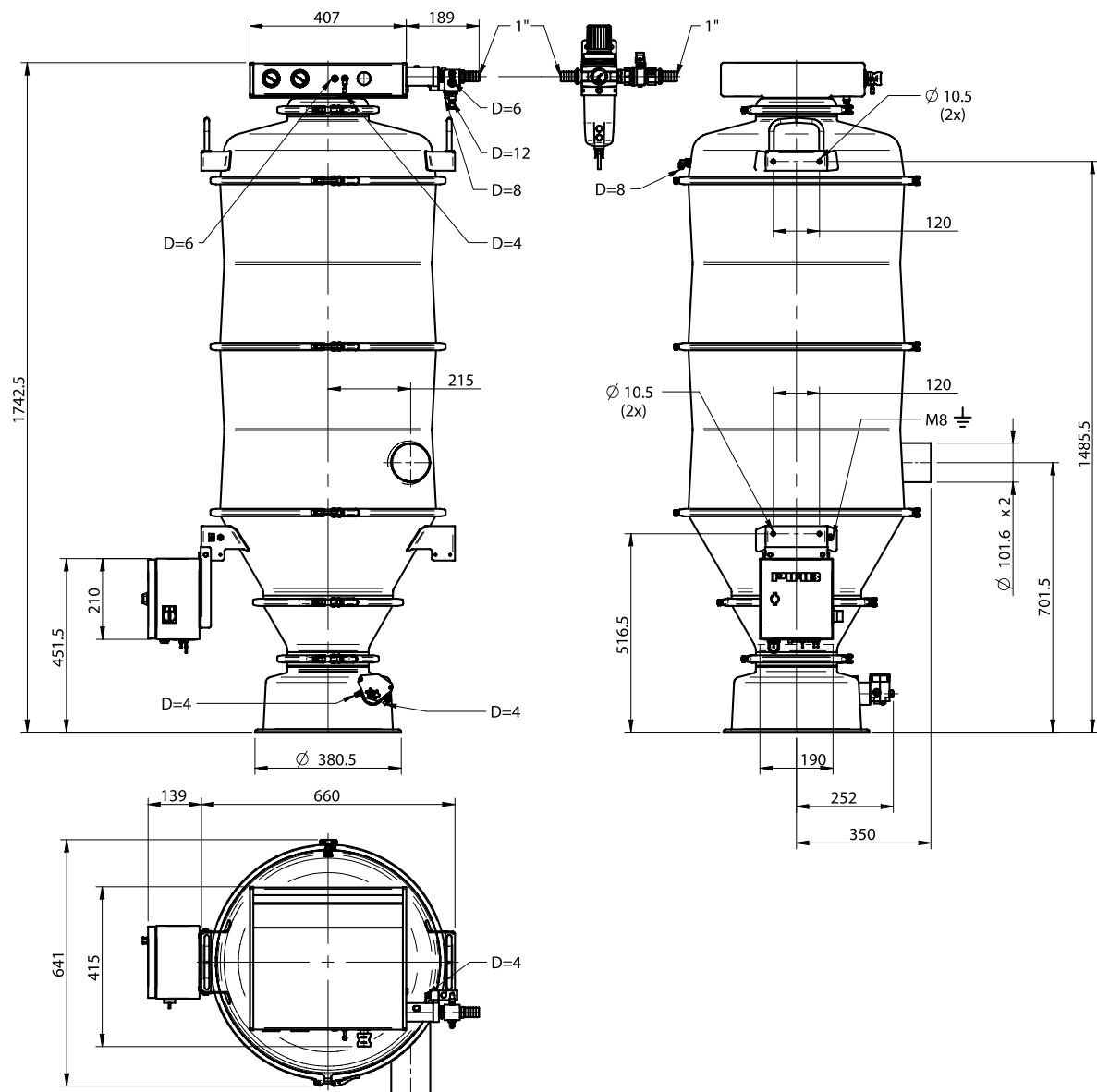

Conveyors C  
COMPLETE

## PARTS INCLUDED

Description	Art. No.
Pump unit Maxi L1200	0103882
Filter unit 5606 textile filter int Q	0106823/2
Connection unit 56/43 D=102 tang, Q	0106239/2
Bottom valve unit 56/57 SS Q	0106816/2
Control unit CU-1B bracket	0103919
Nylon tubing kit, Standard CU-C56	0106981

## C5606-1600



- ▶ Designed mainly for industries handling food, chemical and pharmaceutical products.
- ▶ Solution that contributes to dust-free conveying.
- ▶ All materials in contact with the conveyed product fulfil the requirements of FDA, USDA and 3-A.
- ▶ Turnkey conveyor that is easy to install and start up.
- ▶ Manual dismounting and cleaning.
- ▶ Low sound level.
- ▶ Fully pneumatic.
- ▶ Reusable textile bag filter.

### TECHNICAL DATA

Description	Unit	Value
Feed pressure range	MPa	0.4–0.6
Air consumption range	NI/s	80–112
Vacuum range	-kPa	61–75
Noise level range	dBA	72–76
Material		ASTM 316L, Q
Temperature range	°C	0–60
Weight	kg	78.0
Safety classification		IP54
Filter area	m <sup>2</sup>	1.64
Material batch volume	l	72.3
Min particle size	µm	5.0

### CAPACITY

Capacity ton/h at different conveying distances			
5 m	10 m	20 m	30 m
14.00	7.00	3.50	2.40

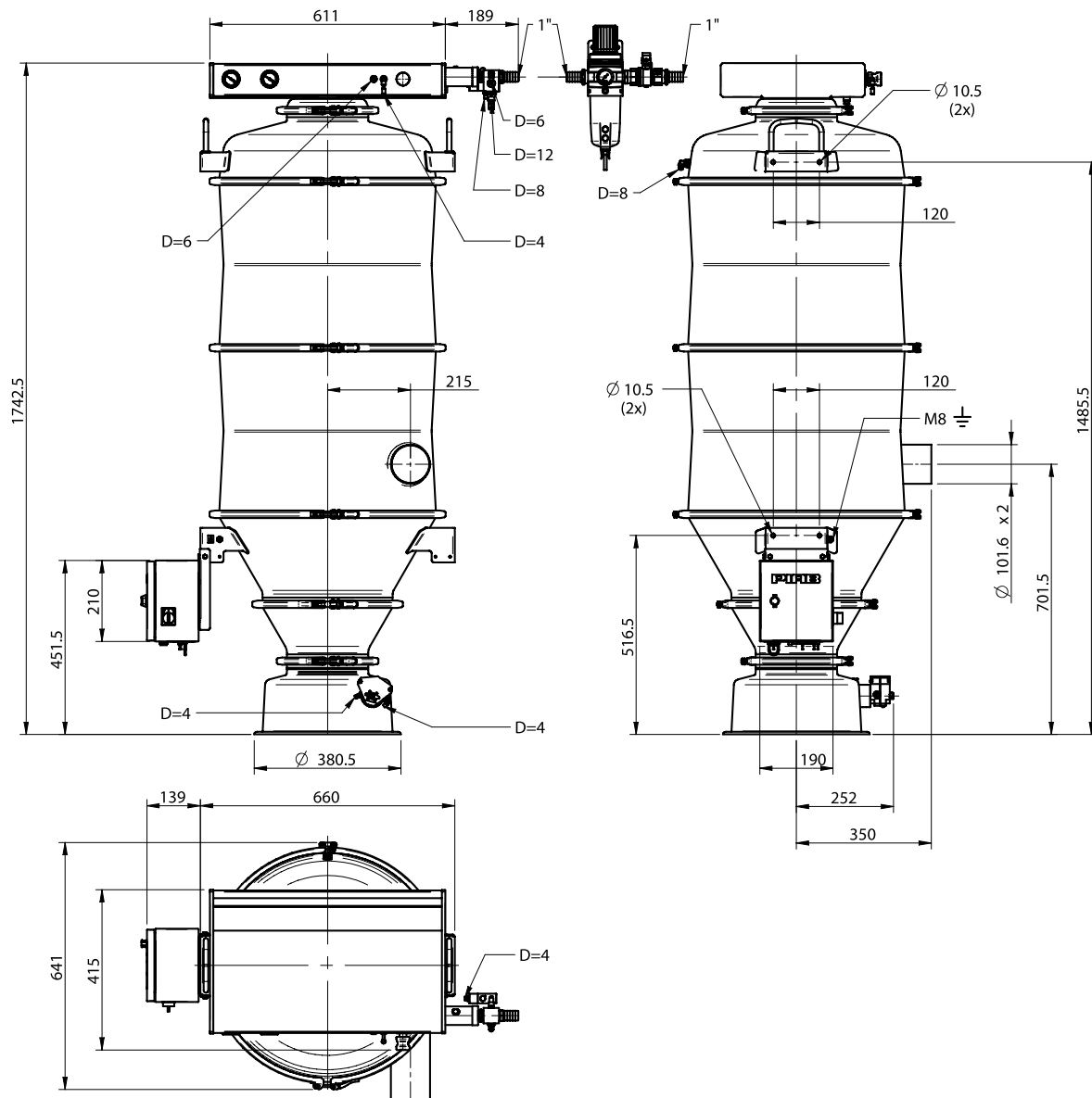

Conveyors C COMPLETE

## PARTS INCLUDED

Description	Art. No.
Pump unit Maxi L1600	0103883
Filter unit 5606 textile filter int Q	0106823/2
Connection unit 56/43 D=102 tang, Q	0106239/2
Connection unit 56/43 D=102 tang, Q	0106239/2
Control unit CU-1B bracket	0103919
Nylon tubing kit, Standard CU-C56	0106981